

EN	SWIMMING POOL HEAT PUMP	User and service manual
FR	POMPE À CHALEUR POUR PISCINE	Manuel d'installation et d'utilisation
NL	ZWEMBAD WARMTEPOMP	Gebruiker en service manual
ES	BOMBA DE CALOR PARA PISCINA	Manual del usuario y de servicio
DE	SCHWIMMBAD - WÄRMEPUMPE	Benutzer - und Wartungshandbuch
IT	PISCINA POMPA DI CALORE	Istruzioni per l'uso e di servizio
PT	BOMBA DE CALOR DE PISCINA	Manual do usuário e serviço

PRO ELYO INVERBOOST NN

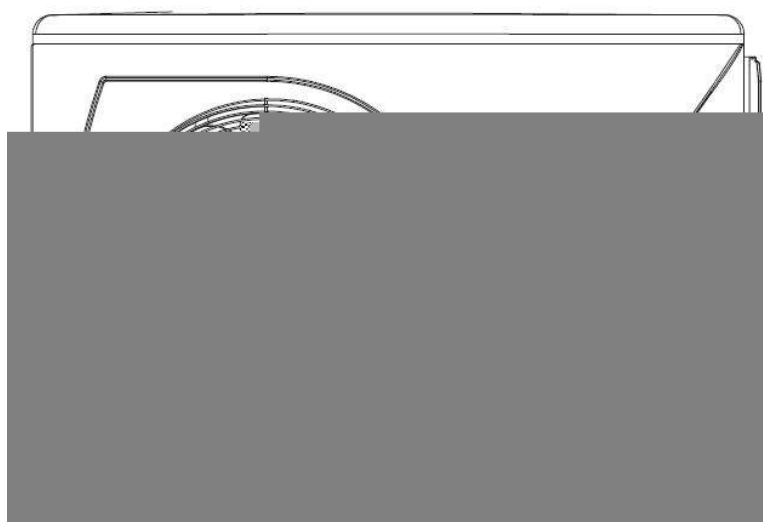

CO2 Regulation	P1
ENGLISH	P09
FRENCH	P65
NEDERLAND	P121
SPANISH	P176
GERMANY	P232
ITALY	P289
PORTUGAL	P343

Regulation (EU) n° 517/2014 of 16/04/14 on fluorinated greenhouse gases and repealing Regulation (EC) n° 842/2006

Leak checks

1. Operators of equipment that contains fluorinated greenhouse gases in quantities of 5 tons of CO₂, equivalent or more and not contained in foams shall ensure that the equipment is checked for leaks.
2. For equipment that contains fluorinated greenhouse gases in quantities of 5 tons of CO₂ equivalent or more, but of less than 50 tons of CO₂ equivalent: at least every 12 months.

Picture of the equivalence CO₂

1. Load in kg and Tons amounting CO₂.

Load and Tons amounting CO ₂	Frequency of test
From 7 at 75 kg load = from 5 at 50 Tons	Each year

Do no release R32 coolant liquid into the atmosphere. This is a fluoride greenhouse effect gas covered by the Kyoto agreement with a global warming potential (GWP) = 675 - (see the European Community regulations on fluoride greenhouse effect gases Regulation (EU) No 517/2014).

Concerning the Gas R32, 7.40kg amounting at 5 tons of CO₂, commitment to check each year.

Training and certification

1. The operator of the relevant application shall ensure that the relevant personnel have obtained the necessary certification, which implies appropriate knowledge of the applicable regulations and standards as well as the necessary competence in emission prevention and recovery of fluorinated greenhouse gases and handling safety the relevant type and size of equipment.

Record keeping

1. Operators of equipment which is required to be checked for leaks, shall establish and maintain records for each piece of such equipment specifying the following information:

- a) The quantity and type of fluorinated greenhouse gases installed;
- b) The quantities of fluorinated greenhouse gases added during installation, maintenance or servicing or due to leakage;
- c) Whether the quantities of installed fluorinated greenhouse gases have been recycled or reclaimed, including the name and address of the recycling or reclamation facility and, where applicable, the certificate number;
- d) The quantity of fluorinated greenhouse gases recovered
- e) The identity of the undertaking which installed, serviced, maintained and where applicable repaired or decommissioned the equipment, including, where applicable, the number of its certificate;
- f) The dates and results of the checks carried out;
- g) If the equipment was decommissioned, the measures taken to recover and dispose of the fluorinated greenhouse gases.

2. The operator shall keep the records for at least five years, undertakings carrying out the activities for operators shall keep copies of the records for at least five years.

Règlen

Verordening (EU) nr. 517/2014 van het Europees Parlement en de Raad van 16 april 2014 betreffende gefluoreerde broeikasgassen en tot intrekking van Verordening (EC) nr. 842/2006

Controle op lekkages

1. Exploitanten van apparatuur die gefluoreerde broeikasgassen in hoeveelheden van 5 ton CO₂, zelfde aantal of meer bevatten en niet verpakt in het isolatieschuim dragen er zorg voor dat de apparatuur wordt gecontroleerd op lekken.

2. Voor apparatuur die gefluoreerde broeikasgassen in hoeveelheden van 5 ton CO₂ zelfde aantal of meer bevatten, maar minder dan 50 ton CO₂-equivalent: tenminste iedere 12 maanden.

Beeld van de CO₂-equivalent

1. Lading in kg en Ton van hoeveelheid CO₂.

Lading en Ton van hoeveelheid CO ₂	Testfrequentie
Van 7 tot 75 kg lading = van 5 tot 50 Ton	Ieder jaar

Laat R32-koelvloeistof niet in de atmosfeer ontsnappen. Dit is een gas van het broeikas effect met fluor dat onder de Kyoto-overeenkomst valt met een broeikas effect (GWP) = 675 - (zie de Europese Gemeenschapswetgeving inzake broeikasgassen met fluoride-verordening (EU) nr. 517/2014).

Met betrekking tot Gas R 32, 7.40kg met de hoeveelheid 5 ton CO₂, toewijding aan jaarlijkse controle.

Training en certificatie

1. De exploitant van de betreffende toepassing zal er voor zorg dragen dat het betrokken personeel de nodige certificering hebben verkregen, hetgeen inhoudt voldoende kennis van de geldende voorschriften en norm te bezitten, alsmede de nodige deskundigheid in emissiepreventie en terugwinning van gefluoreerde broeikasgassen en hanteren van de veiligheid van de betreffende type en de omvang van de apparatuur.

Registratie

1. Exploitanten van apparatuur die verplicht zijn op lekkage te controleren, zullen registers aanmaken en bijhouden voor elk deel van dergelijke apparatuur dat de volgende informatie bevat:

- a) De hoeveelheid en het type van de geïnstalleerde gefluoreerde broeikasgassen;
- b) De hoeveelheden gefluoreerde broeikasgassen toegevoegd tijdens het installeren, onderhoud of de service of als gevolg van lekkage;
- c) Of de hoeveelheden van de geïnstalleerde gefluoreerde broeikasgassen zijn gerecycleerd of teruggewonnen, inclusief de naam en het adres van de recycling- of terugwinningsinstallatie en waar van toepassing het certificaatnummer;
- d) De hoeveelheid teruggewonnen gefluoreerde broeikasgassen
- e) De identiteit van de onderneming die de installatie, reparatie, onderhoud uitvoert en voor zover van toepassing reparaties of verwijdering van apparatuur voor zijn rekening neemt, inclusief, in voorkomend geval, het nummer van haar certificaat;
- f) De data en de resultaten van de verrichte controles;
- g) Indien de apparatuur buitengebruik werd gesteld, de genomen maatregelen voor het terugwinnen en afvoeren van de gefluoreerde broeikasgassen.

2. De exploitant zal de administratie gedurende tenminste vijf jaar bewaren, de ondernemingen die de werkzaamheden voor de exploitanten uitvoeren, moeten tenminste vijf jaar kopieën van de registers bijhouden.

Reglamento (UE) n ° 517/2014 del 16/04/14 sobre gases fluorados de efecto invernadero y anulación del Reglamento (CE) n ° 842/2006

Inspección de fugas

1. Los propietarios o mantenedores de equipos que contenga gases invernaderos fluorados en cantidades de 5 toneladas de CO₂, equivalentes o más y no contenidas en espumas deberán asegurarse de que el equipo se ha comprobado si tiene fugas.
2. Para equipos que contengan gases fluorados de efecto invernadero en cantidades de 5 toneladas de CO₂ equivalente o más, pero de menos de 50 toneladas de CO₂ equivalente: revisar al menos cada 12 meses.

Equivalencia de CO₂

1. Carga en kg y toneladas de CO₂.

Carga y toneladas de CO ₂	Frecuencia de la prueba
De 7 a 75 kg carga = de 5 a 50 Toneladas	Cada año

No expulsar R32 a la atmósfera. Este líquido es un gas fluorado de efecto invernadero cubierto por el protocolo de Kyoto, con un potencial de calentamiento global (GWP) = 675 - (consulte la normativa de la Comunidad Europea sobre el Reglamento de gases fluorados de efecto invernadero, (UE - 517/2014).

En cuanto al Gas R32, 7.40kg con un valor de 5 toneladas de CO₂, se compromete a revisarlo cada año.

Mantenedor Certificado

1. El propietario o mantenedor debe garantizar que el personal pertinente haya obtenido la certificación necesaria, lo que implica un conocimiento adecuado de las normas y reglamentaciones aplicables, así como la competencia necesaria en materia de prevención de emisiones y recuperación de gases fluorados tipo y tamaño del equipo.

Mantenimiento de registros

1. El personal de mantenimiento que requiera verificar fugas deberán establecer y mantener registros para cada pieza de dicho equipo especificando la siguiente información:

- A) La cantidad y el tipo de gases fluorados de efecto invernadero instalados;
- B) La cantidad de gases fluorados de efecto invernadero añadidas durante la instalación, el mantenimiento o el servicio o debido a fugas.
- C) Si se han reciclado o recuperado la cantidad de gases fluorados de efecto invernadero instalados, incluir el nombre y la dirección de la instalación de reciclado o de regeneración y, en su caso, el número del certificado;
- D) La cantidad de gases fluorados de efecto invernadero recuperados
- E) La identidad de la empresa instaladora, reparadora, mantenedora y, en su caso, la empresa desmanteladora del equipo, incluido, en su caso, el número de su certificado;
- F) Las fechas y resultados de los controles efectuados;
- G) Si el equipo fuera desmantelado, las medidas adoptadas para recuperar y tratar de los gases fluorados de efecto invernadero

2. El operador debe conservar los registros durante al menos cinco años, las empresas que realicen las actividades de los operadores deben conservar las copias de los registros durante al menos cinco años.

Verordnung (EU) Nr. 517/2014 vom 16/04/14 über fluorierte Treibhausgase und die Verordnung (EG) zur Aufhebung Nr. 842/2006

Dichtheitsprüfung

1. Die Betreiber von den Geräte, die die fluorierte Treibhausgase in Mengen von 5 Tonnen CO₂-Äquivalent oder mehr enthalten und nicht in Schäumen enthalten, müssen sicherstellen, dass das Gerät auf Dichtheit überprüft wird.
2. Für die Geräte, die fluorierte Treibhausgase in Mengen von 5 Tonnen 5 Tonnen CO₂-Äquivalent oder mehr enthalten aber weniger als 50 Tonnen CO₂-Äquivalent enthalten: mindestens alle 12 Monate.

Bild der Gleichwertigkeit CO₂

Belastung und Tonnen von CO ₂	Häufigkeit der Prüfung
Von 7 bei 75 kg Belastung = von 5 bei 50 Tonnen	Jedes Jahr

Lassen Sie keine R32-Kühlfüssigkeit in die Atmosphäre gelangen. Dies ist ein Fluorid-Treibhauseffektgas, das unter das Kyoto-Abkommen fällt, mit einem Potenzial für die globale Erwärmung (GWP) = 675 - (siehe Verordnung der Europäischen Gemeinschaft zu Fluorid-Treibhauseffekt-Verordnung (EU) Nr. 517/2014).

In Bezug auf die Gas R32, 7.40 kg in Höhe von 5 Tonnen CO₂, Engagement für die Überprüfung jedes Jahr.

Ausbildung und Zertifizierung

1. Die Betreiber der betreffenden Anwendung sollen dafür Sorge tragen, dass die zuständige Person die erforderliche Zertifizierung erlangt hat, die die angemessene Kenntnisse der geltenden Vorschriften und Normen sowie die notwendige Kompetenz in Bezug auf die Emissionsvermeidung und -verwertung von fluorierten Treibhausgasen und der Handhabungssicherheit der betreffenden Typen und Größe der Ausrüstung beinhaltet.

Aufbewahrung der Aufzeichnungen

1. Die Betreiber von den Geräte, die auf Dichtheit überprüft werden müssen, müssen für jedes Gerät, das die folgenden Angaben enthält, Aufzeichnungen erstellen und verwalten:
 - a) Die Menge und Art der installierten fluorierten Treibhausgase;
 - b) Die Mengen an fluorierten Treibhausgasen, die während der Installation, Wartung oder Service oder aufgrund von Leckagen hinzugefügt werden;
 - c) Ob die Mengen der installierten fluorierten Treibhausgase wiederverwandt oder zurückgefordert wurden, einschließlich der Name und Anschrift der Wiederverwendung oder Rückgewinnungsanlage und gegebenenfalls der Bescheinigungsnummer;
 - d) Die Menge der fluorierten Treibhausgase wiederhergestellt wird;
 - e) Die Identität des Unternehmens, das die Ausrüstung installiert, gewartet und gegebenenfalls repariert oder außer Betrieb hat, gegebenenfalls einschließlich der Nummer des Zertifikats;
 - f) Datum und Ergebnisse der Prüfung durchgeführt werden;
 - g) Wenn das Gerät außer Betrieb hat, wurden die Maßnahmen zur Rückgewinnung und Beseitigung der fluorierten Treibhausgase getroffen.
2. Die Betreiber bewahrendie Aufzeichnungen für mindestens fünf Jahre lang auf, wobei die Unternehmen, die die Tätigkeiten für die Betreiber ausführen, die Aufzeichnungen für mindestens fünf Jahre lang aufbewahren soll.

Regolamento (UE) n ° 517/2014 del 16/04/14 sui gas serra fluorurati ad effetto serra e che abroga il regolamento (CE) n ° 842/2006

controlli di perdite

1. Gli operatori delle apparecchiature che contengono gas fluorurati ad effetto serra con quantità di 5 tonnellate di CO₂, equivalenti o superiore e non contiene nelle schiume, devono garantire che il materiale sia stato verificato la presenza di perdite.
2. Per le apparecchiature che contengono gas fluorurati ad effetto serra con quantità di 5 tonnellate di CO₂ equivalente o superiore, ma inferiore a 50 tonnellate di CO₂ equivalente: controllare almeno ogni 12 mesi.

Immagine del CO₂ dell'equivalenza

1. Caricare il totale CO₂ in chili e tonnellate.

Caricare il totale CO ₂ in chili e tonnellate	Frequenza di test
Dal 7 a 75 chili di carico = dal 5 a 50 tonnellate	Annuale

Non permettere che il refrigerante R32 entri nell'atmosfera. Si tratta di un gas fluorurato ad effetto serra coperto dall'accordo di Kyoto, con potenziale di riscaldamento globale (GWP) = 675 - (cfr. Regolamento della Comunità europea sul regolamento sui fluoro in serra (UE) n. 517/2014).

Per quanto riguarda la Gas R32, 7.40 chili pari a 5 tonnellate di CO₂, l'obbligo a controllare ogni anno.

Formazione e certificazione

1. Il gestore della relativa domanda deve assicurare che il personale interessato abbia ottenuto la certificazione necessaria, che implica una conoscenza appropriata dei regolamenti e delle norme vigenti, nonché la necessaria competenza in materia di prevenzione delle emissioni e di recupero dei gas fluorurati ad effetto serra e la sicurezza la gestione dell'apparecchiatura del relativo tipo e dimensioni.

Conservazione di registri

1. Gli operatori di attrezzatura che è necessario per controllare la presenza di perdite, deve stabilire e mantenere i record per ogni pezzo di tali attrezzature specificando le seguenti informazioni:
 - a) La quantità e il tipo di gas fluorurati ad effetto serra installati;
 - b) Le quantità di gas fluorurati ad effetto serra aggiunte durante l'installazione, manutenzione o assistenza o a causa di perdite;
 - c) Se la quantità di gas fluorurati ad effetto serra installate sono state riciclate e rigenerate, insieme al nome e l'indirizzo del centro di riciclaggio o recupero e, se del caso, il numero del certificato;
 - d) la quantità di gas fluorurati ad effetto serra recuperata
 - e) L'identità dell'impresa che ha installato, servito, mantenuto e, se del caso riparato o decommissionato le attrezzature, include, se del caso, il numero del proprio certificato;
 - f) Le date e i risultati dei controlli effettuati;
 - g) Se l'apparecchiatura è stata decommissionata, le misure adottate per recuperare e sistemare i gas fluorurati ad effetto serra.
2. L'operatore deve conservare i registri per almeno cinque anni, le imprese che svolgono le attività per gli operatori devono tenere copie dei registri per almeno cinque anni.

Regulamento (UE) n.º 517/2014, de 16/04/14, relativo aos gases fluorados com efeito de estufa e que revoga o Regulamento (CE) n.º 842/2006

Verificações de vazamentos

1. Os operadores de equipamentos que contenham gases de efeito estufa fluorados em quantidades de 5 toneladas de CO₂, equivalentes ou mais e não contidos em espumas devem assegurar que o equipamento seja verificado quanto a vazamentos.
2. Para equipamento que contenha gases fluorados com efeito de estufa em quantidades iguais ou superiores a 5 toneladas de equivalente CO₂, mas inferior a 50 toneladas de equivalente CO₂: pelo menos de 12 em 12 meses.

Imagem da equivalência de CO₂

1. Coloque em kg e toneladas em CO₂.

Carga e Toneladas de CO ₂	Frequência do teste
From 7 at 75 kg load = from 5 at 50 Tons	Cada ano

Não libere líquido refrigerante R32 na atmosfera. Este é um gás fluoreto com efeito de estufa coberto pelo acordo de Quioto com um potencial de aquecimento global (GWP) = 675 - (ver a regulamentação da Comunidade Europeia sobre os gases fluorados com efeito de estufa (EU) No 517/2014).

Em relação à Gas R32, 7.40kg no valor de 5 toneladas de CO₂, compromisso de verificar a cada ano.

Treinamento e Certificação

1. O operador da aplicação relevante deve assegurar que o pessoal relevante obteve a certificação necessária, o que implica o conhecimento adequado dos regulamentos e normas aplicáveis, bem como a competência necessária na prevenção e recuperação de gases fluorados com efeito de estufa e a segurança do tipo e tamanho do equipamento.

Manutenção de registos

1. Os operadores de equipamentos que devem ser verificados quanto a vazamentos devem estabelecer e manter registos para cada peça de equipamento, especificando as seguintes informações:
 - a) Quantidade e tipo de gases fluorados com efeito de estufa instalados;
 - b) As quantidades de gases fluorados com efeito de estufa adicionados durante a instalação, manutenção ou assistência ou devido a fugas;
 - c) Se as quantidades de gases fluorados com efeito de estufa instalados foram recicladas ou valorizadas, incluindo o nome e endereço da instalação de reciclagem ou recuperação e, quando aplicável, o número do certificado;
 - d) A quantidade de gases fluorados com efeito de estufa recuperados
 - e) A identidade da empresa que instalou, reparou, manteve e, se for caso disso, reparou ou desactivou o equipamento, incluindo, quando aplicável, o número do seu certificado;
 - f) As datas e resultados dos controlos realizados;
 - g) Se o equipamento foi descomissionado, as medidas tomadas para recuperar e eliminar os gases fluorados com efeito de estufa.
2. **O operador deve conservar os registos durante pelo menos cinco anos, as empresas que executam as actividades dos operadores devem conservar cópias dos registos durante pelo menos cinco anos.**

SWIMMING POOL HEAT PUMP

PRO ELYO INVERBOOST NN

1. Description
2. Transport information
3. Specifications
4. Accessories and options
5. Location and connection
6. Electrical Wiring
7. Start-up of the Heat Pump
8. Troubleshooting
9. Exploded Diagram

Thank you for using PRO ELYO INVERBOOST NN swimming pool heat pump for your pool heating, it will heat your pool water and keep the constant temperature when the air ambient temperature is at -20 to 50°C.



ATTENTION: This manual includes all the necessary information for the use and the installation of your heat pump.

- The installer must read the manual and follow the instructions of implementation and maintenance.
- The installer is responsible for the installation of the product and should follow all the instructions of the manufacturer and the regulations in application. Incorrect installation will invalidate the guarantee.
- The manufacturer declines any responsibility for the damage caused by any third party, object ingress and of the errors due to the installation that do not follow the manual guidelines. Any use that is not as intended by the manufacturer will invalidate the guarantee.



WARNING:

Important notice:

- Please always keep the heat pump in a well ventilated place and away from anything which could cause fire.
- Do not braze or weld the pipe if there is refrigerant inside machine. Please do not charge the gas when in a confined space.
- Please always empty the water in heat pump during winter time or when the ambient temperature drops below 0°C, or else the Titanium exchanger will be damaged because of being frozen, in such case, your warranty will be lost.
- Please always cut the power supply if you want to open the cabinet to reach inside the heat pump.
- Please keep the display controller in a dry area to protect the display controller from being damaged by humidity.

1.1 Included with your Heat Pump

- Water connection assembly 50 mm (pcs: 2)
- User and service manual
- Reducer connection
- 10 meters' signal wire
- Waterproof box
- Winter cover
- Anti-vibration base (pcs: 4)

1.2 Dimension

Model: 71676

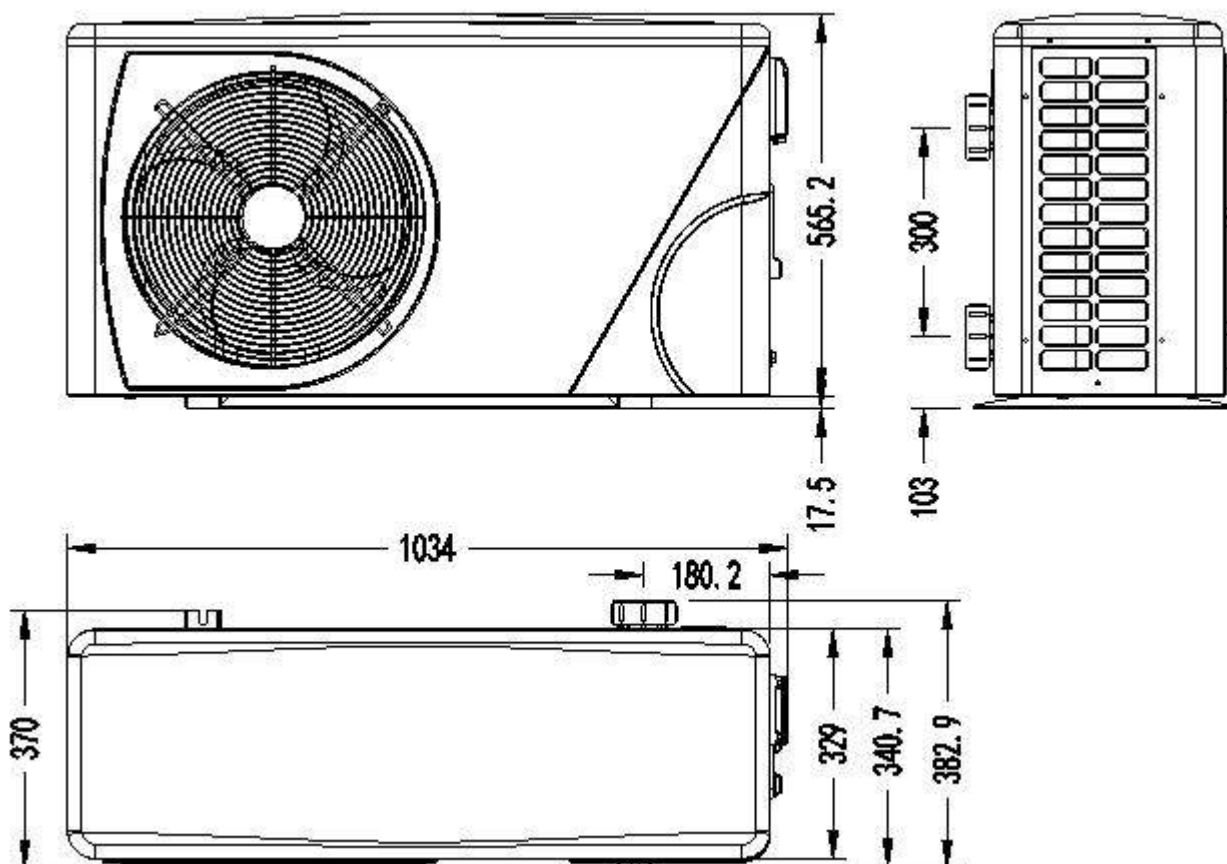

Models: 71677/71678/71679

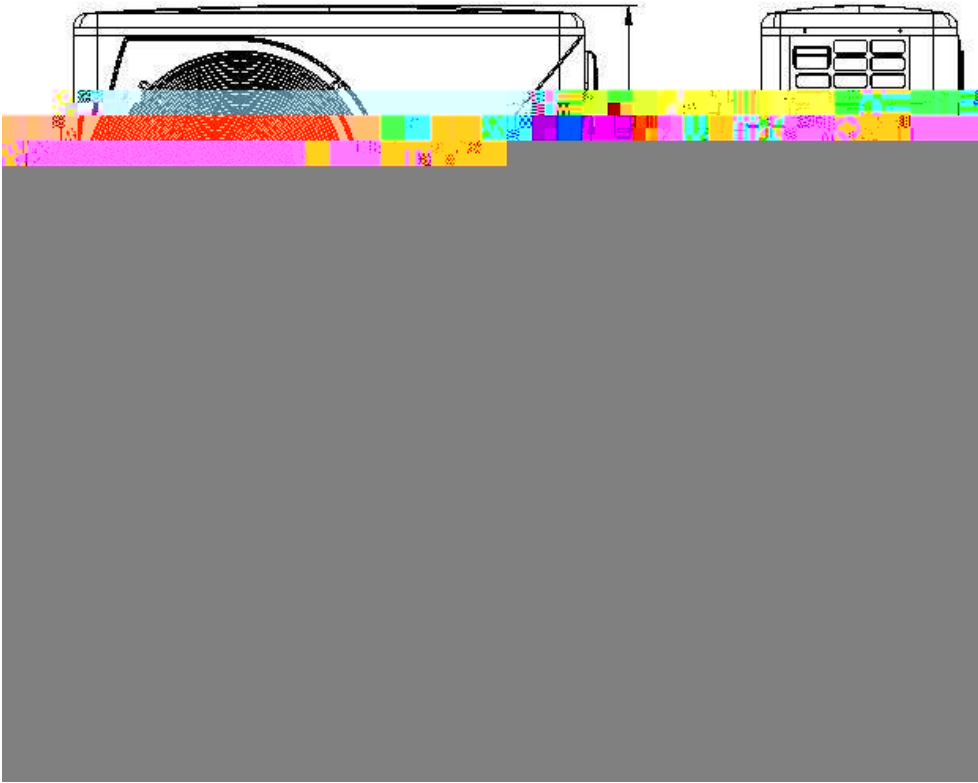

Models: 71680/71681

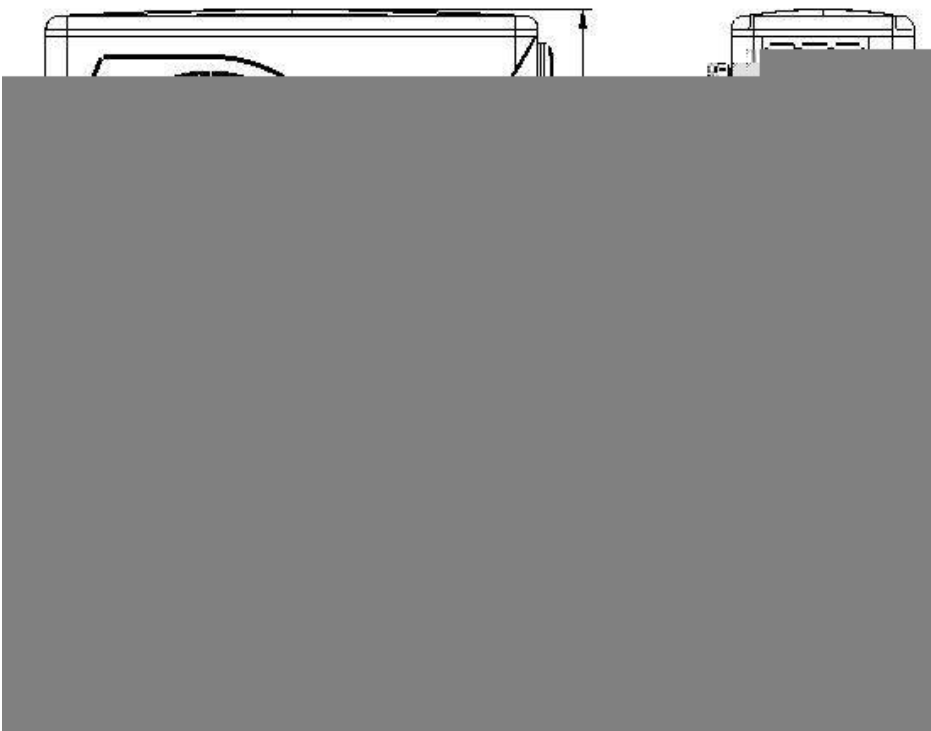

Models: 71682/71683/68821/68822/68823



2.1 Delivery of the unit

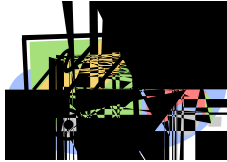

Technical data PRO ELYO INVERBOOST NN pool heat pumps

CE Standard, R32, ABS Cabinet

MODEL		PROELYXP07i	PROELYXP09i	PROELYXP11i	PROELYXP14i
CODE		71676	71677	71678	71679
* Performance at Air 28°C, Water 28°C, Humidity 80%					
Heating capacity	Kw	7-3.1	9-2.3	11-2.9	14-3.2
Power consumption	Kw	1.04-0.21	1.34-0.14	1.64-0.18	2.09-0.2
C.O.P.		15-6.7	16-6.7	16-6.7	16-6.7
* Performance at Air 15°C, Water 26°C, Humidity 70%					
Heating capacity	Kw	4.7-2.5	6.6-1.9	7.9-2	9.5-2.3
Power consumption	Kw	0.94-0.32	1.32-0.24	1.58-0.25	1.9-0.29
C.O.P.		7.9-5	8.0-5	8.0-5	8.0-5
* Performance at Air 0°C, Water 26°C, Humidity 78%					
Heating capacity	Kw	3.44-1.7	4.11-2.3	5.54-3.0	6.85-3.8
Power consumption	Kw	1.23-0.38	1.47-0.82	1.98-0.68	2.45-0.85
C.O.P.		4.5-2.8	4.4-2.8	4.4-2.8	4.5-2.8
* Performance at Air -10°C, Water 26°C, Humidity 78%					
Heating capacity	Kw	2.41-1.5	3.13-2.0	3.87-2.7	5.1-3.15
Power consumption	Kw	1.21-0.35	1.42-0.53	1.76-0.69	2.32-0.81
C.O.P.		4.3-2	3.8-2.2	3.9-2.2	3.9-2.2
* General data					
Compressor type		MITSUBISHI INVERTER COMPRESSOR			
Voltage	V	220-240V/50Hz or 60Hz/1PH			
Rated current	A	4.6	5.9	7.2	9.2
Minimum fuse	A	7	9	11	14
Advised pool volume	m ³	10-26	12-35	16-60	18-66
Advised water flux	m ³ /h	2.5	3.0	3.7	4.0
Water pressure drop	Kpa	12	12	14	15
Heat exchanger		Twist-titanium tube in PVC			
Water connection	mm	50			
No. of Fan		1			
Ventilation type		Horizontal			
Fan speed	RPM	500-850		550-850	
Power input of Fan	W	6-35		22-82	32-110
Noise level(10m)	dB(A)	≤ 41	≤ 42	≤ 42	≤ 43
Noise level(1m)	dB(A)	38-51	39-52	40-52	40-54
Refrigerant (R32)	g	650	700	1000	1100
CO2 equivalent	Tonne	0.44	0.47	0.68	0.74
* Dimension/ Weight					
Net weight	kg	56	68	73	78
Gross weight	kg	68	73	78	83
Net dimension	mm	1008*380*577	1050*440*709		
Packing dimension	mm	1095*430*705	1130*470*850		

Technical data PRO ELYO INVERBOOST NN pool heat pumps

CE Standard, R32, ABS Cabinet

MODEL		PROELYXP16i	PROELYXP20i	PROELYXP26i	PROELYXP30i
CODE		71680	71681	71682	71683
* Performance at Air 28°C, Water 28°C, Humidity 80%					
Heating capacity	Kw	16-3.8	20-4.7	26-5.9	30-6.8
Power consumption	Kw	2.39-0.24	2.99-0.29	3.88-0.37	4.55-0.43
C.O.P.		16-6.7	16-6.7	16-6.7	16-6.6
* Performance at Air 15°C, Water 26°C, Humidity 70%					
Heating capacity	Kw	11.2-3	14-3.9	18-5.4	22.8-5.6
Power consumption	Kw	2.24-0.38	2.8-0.49	3.6-0.68	4.56-0.68
C.O.P.		8.2-5	8.2-5	8.2-5	8.2-5
* Performance at Air 0°C, Water 26°C, Humidity 70%					

Technical data PRO ELYO INVERBOOST NN pool heat pumps

CE Standard, R410A, ABS Cabinet

MODEL		Pro Elyo Inverboost NN26T	Pro Elyo Inverboost NN 35	Pro Elyo Inverboost NN35T
CODE		68821	68822	68823
* Performance at Air 28°C, Water 28°C, Humidity 80%				
Heating capacity	Kw	26-5.9	35-8	35-8
Power consumption	Kw	3.88-0.37	5.22-0.5	5.22-0.5
C.O.P.		16-6.7	16-6.7	16-6.7
* Performance at Air 15°C, Water 26°C, Humidity 70%				
Heating capacity	Kw	18-5.4	24-5.6	24-5.6
Power consumption	Kw	3.6-0.68	4.8-0.68	4.8-0.68
C.O.P.		8.2-5	8.2-5	8.2-5
* Performance at Air 0°C, Water 26°C, Humidity 78%				
Heating capacity	Kw	13-6.7	15.8-3.7	15.8-3.7
Power consumption	Kw	4.64-1.52	4.46-0.63	4.46-0.63
C.O.P.		4.4-2.8	5.8-3.6	5.8-3.6
* Performance at Air -10°C, Water 26°C, Humidity 78%				
Heating capacity	Kw	10.4-5.9	11.6-3.1	11.6-3.1
Power consumption	Kw	4.73-1.51	4.77-0.6	4.77-0.6
C.O.P.		3.9-2.2	5.2-2.45	5.2-2.45
* General data				
Compressor type		MITSUBISHI INVERTOR COMPRESSOR		
Voltage	V	380V/50Hz or 60Hz/3PH	220~240V /50Hz or 60Hz/1PH	380V/50Hz or 60Hz/3PH
Rated current	A	7	22.9	8.4
Minimum fuse	A	10.5	34	13
Advised pool volume	m ³	65-132	78-160	78-160
Advised water flux	m3/h	8.00	10.0	10.0
Water pressure	Kpa	20	25	25
Heat exchanger		Twist-titanium tube in PVC		
Water connection	mm	50		
No, of Fan		2		
Ventilation type		Horizontal		
Fan speed	RPM	(550-850)*2		
Power input of Fan	W	(32-110)*2		
Noise level(10m)	dB(A)	/	/	/
Noise level(1m)	dB(A)	42-60	42-60	42-60
Refrigerant (R410a)	g	3800	4000	4000
CO2 equivalent	Tonne	7.94	8.36	8.36
* Dimension / Weight				
Net weight	kg	128		
Gross weight	kg	146		
Net dimension	mm	1050*452*1295		
Packing dimension	mm	1130*515*1430		

* Above data are subject to modification without notice.

4.1 Accessories list







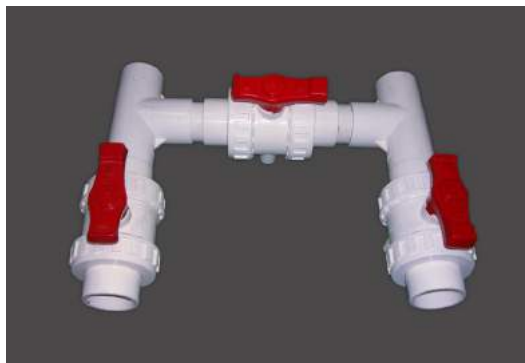

		
<p>Anti-vibration base, 4 pcs</p>	<p>Draining plug, 2 pcs</p>	<p>Waterproof box, 1 pc</p>
		
<p>10M signal wire, 1 pc Modbus signal wire, 1 pc</p>	<p>Water connection assembly, 2 sets</p>	<p>Winter Cover, 1 pc</p>

4.2 The By-Pass Kit

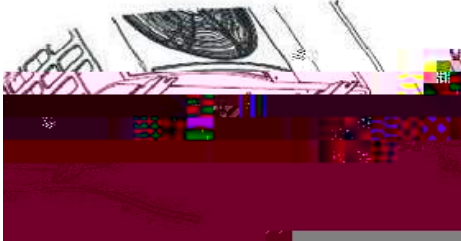
The By-Pass Kit is the essential accessory for the installation of your heat pump, it is also a tool for the optimization of the heating of the water. The valves allows the optimum flow of water using a manometer to make sure the optimized running of the compressor, see paragraph 5.6 controls of the pressure.



4.3 Accessories Installation

	<p>Anti-vibration bases</p> <ol style="list-style-type: none"> 1. Take out 4 Anti-vibration bases 2. Install them on the bottom of machine.
 	<p>Draining plug</p> <ol style="list-style-type: none"> 1. Install the draining plug under the bottom panel 2. Connect with a water pipe to drain out the water. <p>Note: Lift the heat pump to install the draining plug. Never overturn the heat pump, it could damage the compressor.</p>
	<p>Water Inlet & outlet connection</p> <ol style="list-style-type: none"> 1. Install the two joints like the picture shows 2. Screw them onto the water Inlet & outlet connection
 	<p>Mains Cable wiring</p> <ol style="list-style-type: none"> 1. Open the cover of the terminal box (marked red) on the side of machine 2. Tight the cables in the correct connections, L N E, inside the terminal block.
 	<p>Filtration pump wiring (Dry contact)</p> <ol style="list-style-type: none"> 1. Open the cover of the terminal box (marked red) on the side of machine 2. Tight the cables in the correct connections, 1 2, inside the terminal block.

ATTENTION:

Please observe the following rules when installing the heat pump:

1. Any addition of chemicals must take place in the piping located **downstream** from the heat pump.
2. Always keep the heat pump upright. If the unit has been held at an angle, wait at least 24 hours before applying mains power to the heat pump.

5.1 Heat pump location

The unit will work properly in any desired location as long as the following three items are present:

1. Fresh air
2. Electricity
3. Swimming pool filters

The unit may be installed in virtually any **outdoor** location as long as the specified minimum distances to other objects are maintained (see drawing below). Please consult your installer for installation with an indoor pool. Installation in a windy location does not present any problem at all.

ATTENTION: Never install the unit in a closed room with a limited air volume in which the air expelled from the unit will be reused, or close to shrubbery that could block the air inlet. Such locations impair the continuous supply of fresh air, resulting in reduced efficiency and possibly preventing sufficient heat output.

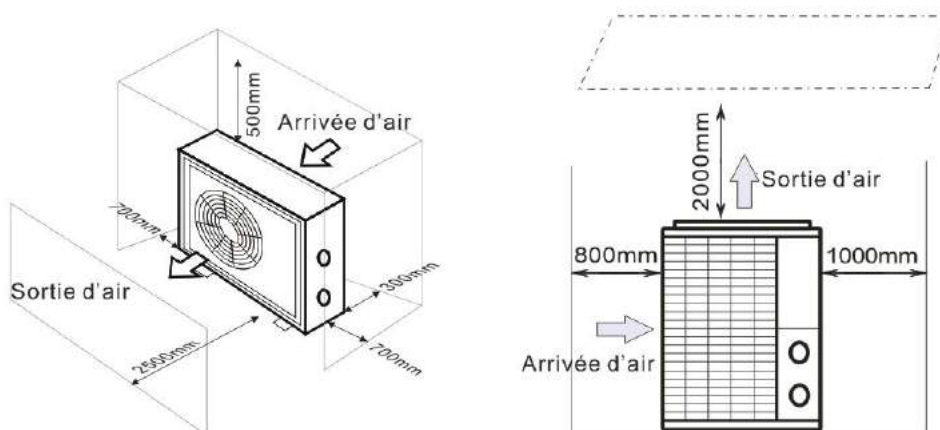

5.2 Check-valve installation

NOTE

Note: If automatic dosing equipment for chlorine and acidity (pH) is used, it is essential to protect the heat pump against excessively high chemical concentrations which may corrode the heat exchanger. For this reason, equipment of this sort must always be fitted in the piping on the **downstream** side of the heat pump, and it is recommended to install a check-valve to prevent reverse flow in the absence of water circulation.

Damage to the heat pump caused by failure to observe this instruction is not covered by the warranty. 

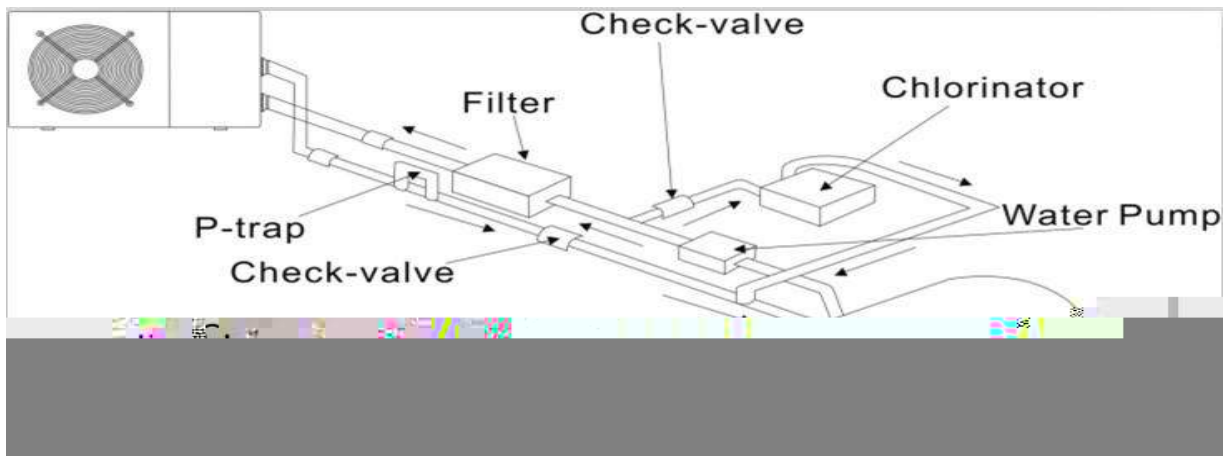

5.3 Typical arrangement

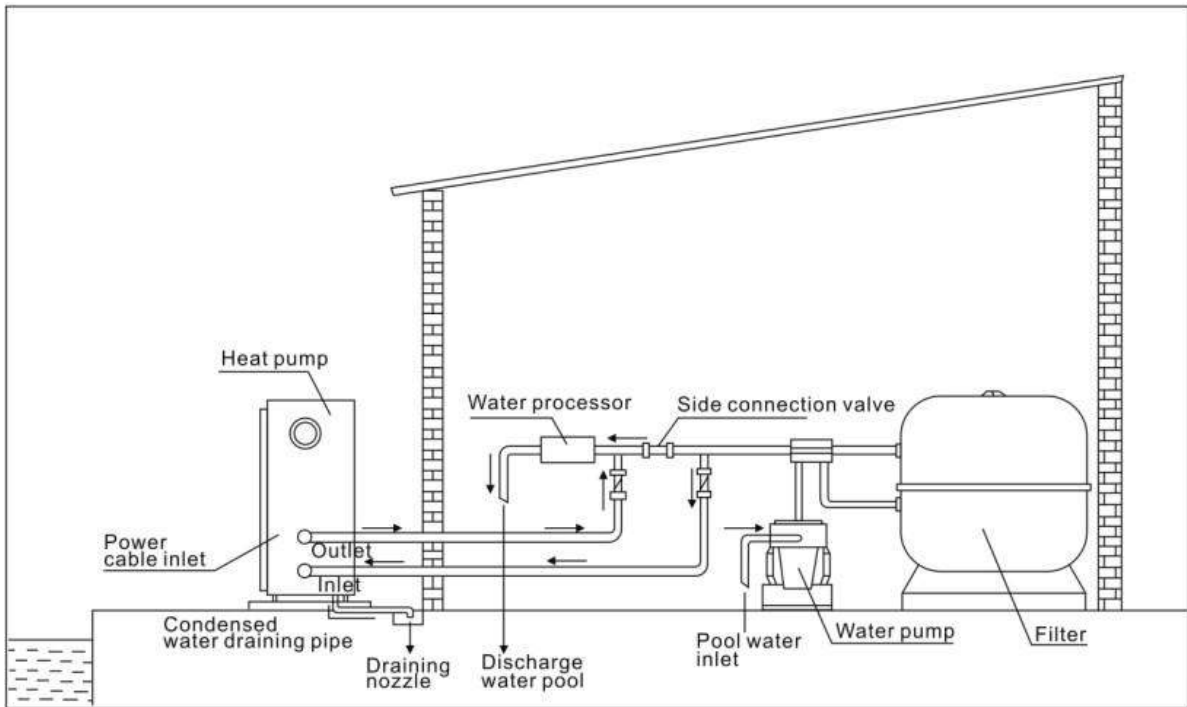

This arrangement is only an illustrative example.

NOTE

The factory supplies only the heat pump. All other components, including a bypass if necessary, must be provided by the user or the installer.

ATTENTION:

In order to heat the water in the pool (or hot tub), the filtration pump must be running so the water is circulating through the heat pump. The heat pump will not start up if the water is not circulating.

5. Location and connection

5.4 Initial operation

After all connections have been made and checked, carry out the following procedure:

1. Switch on the filtration pump. Check for leaks and verify that water is flowing to and from the swimming pool.
2. Connect power to the heat pump and press the On/Off button  on the electronic control panel. The unit will start up after the time delay expires (see below).
3. After a few minutes, check whether the air blowing out of the unit is cooler.
4. When the filtration pump is turned off, the unit should also turn off automatically.
5. Allow the heat pump and the filtration pump to run 24 hours a day until the desired water temperature is reached. The heat pump will stop running at this point +1°C. After this, it will restart automatically (as long as the filtration pump is running) whenever the swimming pool water temperature drops 1 degree below the set temperature (for example, if you set the temperature 28°C, the heat pump will stop when the temperature at 29°C. While it will restart when the temperature of the water down to 27°C)

Depending on the initial temperature of the water in the swimming pool and the air temperature, it may take several days to heat the water to the desired temperature. A good swimming pool cover can dramatically reduce the required length of time.

NOTE

Water Flow Switch:

It is equipped with a flow switch for protecting the HP unit running with adequate water flow rate. It will turn on when the filtration pump runs and shut it off when the pump shuts off.

Time delay - The heat pump has a built-in 3-minute start-up delay to protect the circuitry and avoid excessive electrical contactor wear. The unit will restart automatically after this time delay expires. Even a brief power interruption will trigger this time delay and prevent the unit from restarting immediately. Additional power interruptions during this delay period do not affect the 3-minute duration of the delay.

5.5 Condensation

The air drawn into the heat pump is cooled by the operation of the heat pump for heating the pool water, which may cause condensation on the fins of the evaporator.

NOTE

The amount of condensation may be as much as several liters per hour at high humidity. The condensate will drain from the bottom of the heat pump. This is sometimes mistakenly regarded as a water leak.

5.6 Pressure gauge display (R32)

Examine the pressure gauge which indicates the refrigerant gas pressure of the unit, the below table shows the normal value of the gas pressure (R32) when the machine is in power off or running conditions.

Unit Condition	Power Off			
	Ambient (°C)	-5~5	5~15	15~25
Water temp (°C)	/	/	/	/
Pressure gauge (Mpa)	0.59~0.85	0.85~1.18	1.18~1.59	1.59~2.1

Unit Condition	Running				
	Ambient (°C)	/	/	/	/
Water temp (°C)	10~15	15~20	20~25	25~30	30~35
Pressure gauge (Mpa)	1.1~1.6	1.3~1.8	1.5~2.1	1.7~2.4	1.9~2.7

6.1 Inverter swimming pool heat pump wiring diagram

Ref. 71676/71677/71678/71679/71680

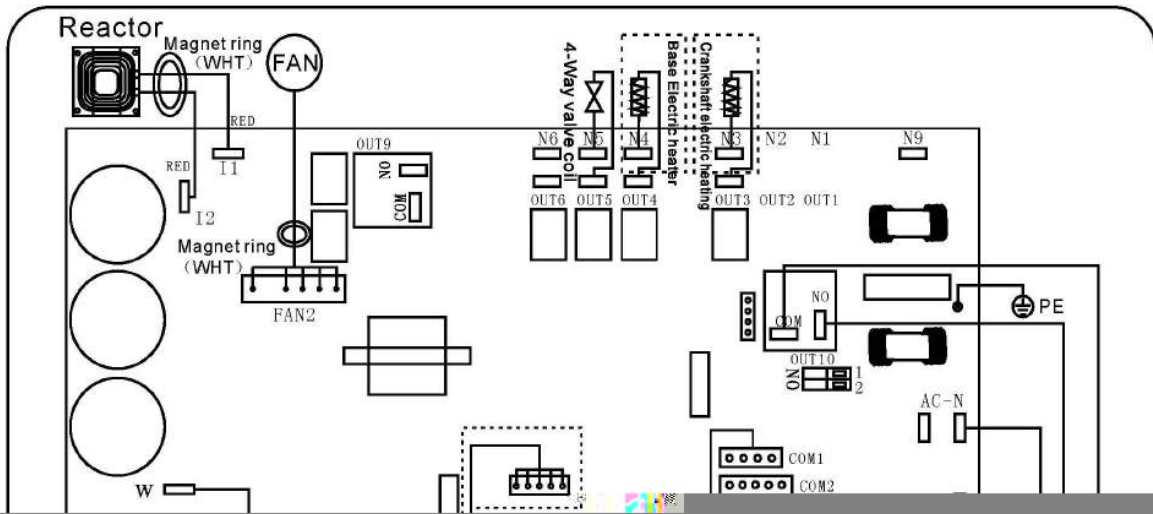

6.2 Inverter swimming pool heat pump wiring diagram

Ref: 71681

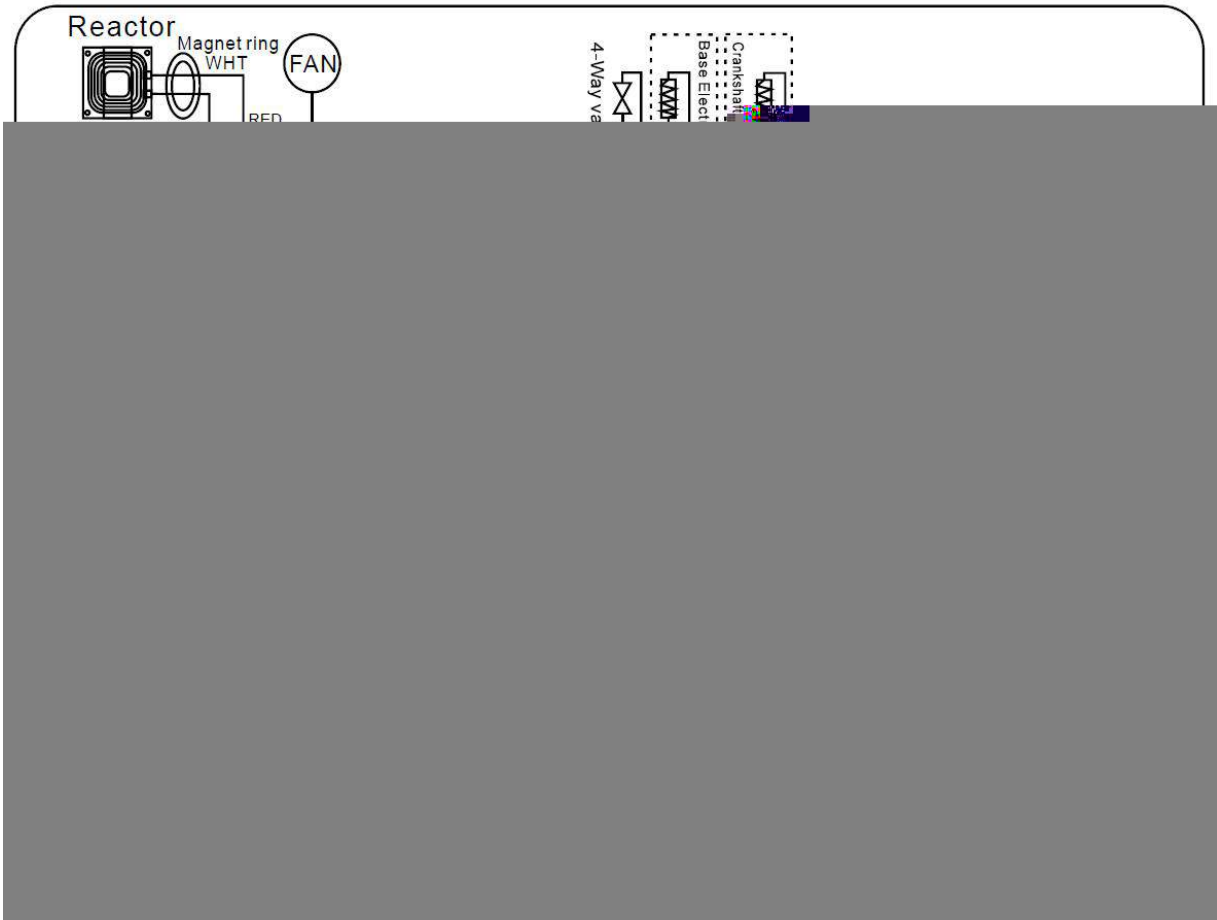

6.3 Inverter swimming pool heat pump wiring diagram

Ref: 71682/71683



6.4 Inverter swimming pool heat pump wiring diagram

Ref. 68822 (R410A)

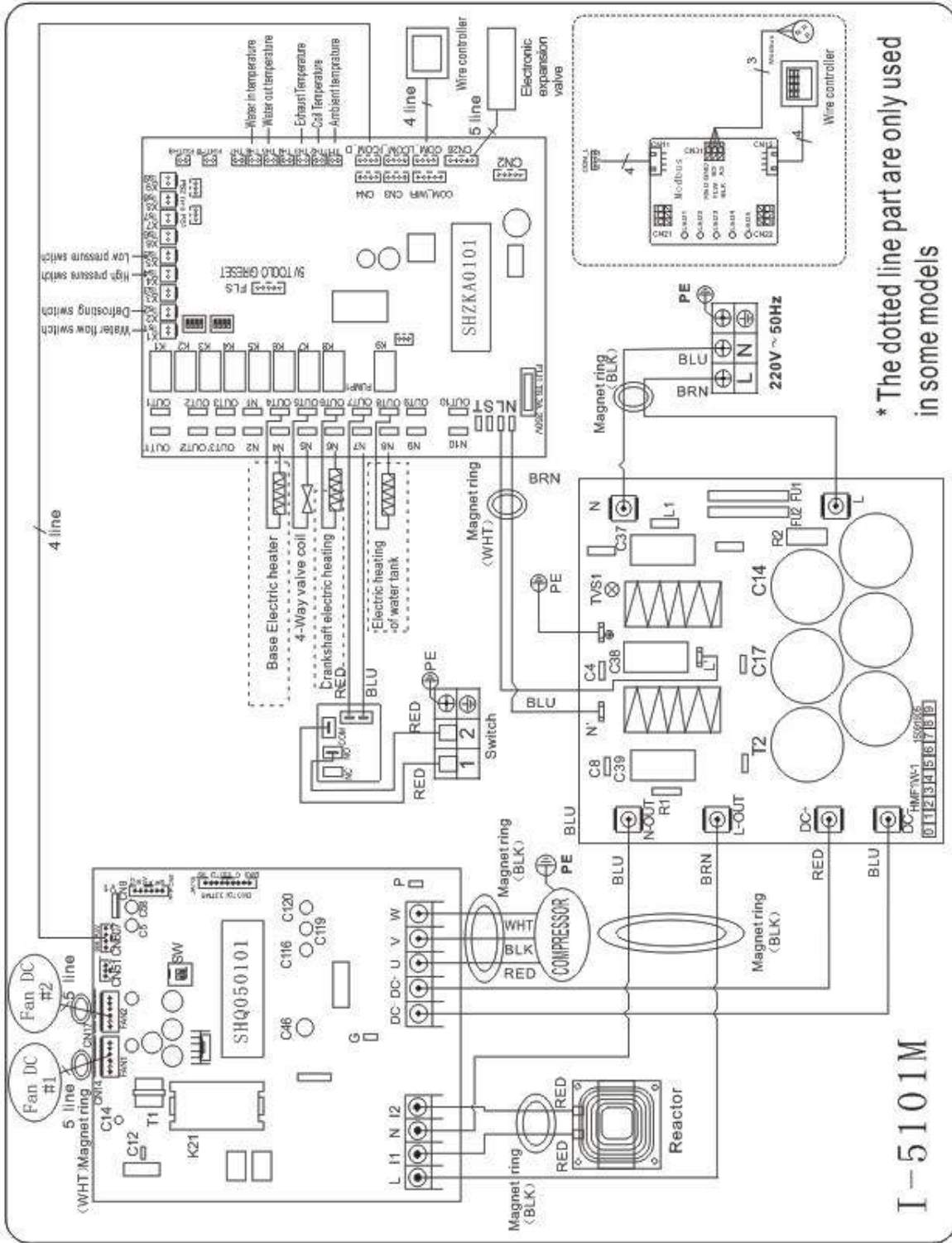

6.5 Inverter swimming pool heat pump wiring diagram

Ref. 68821/68823 (R410A)

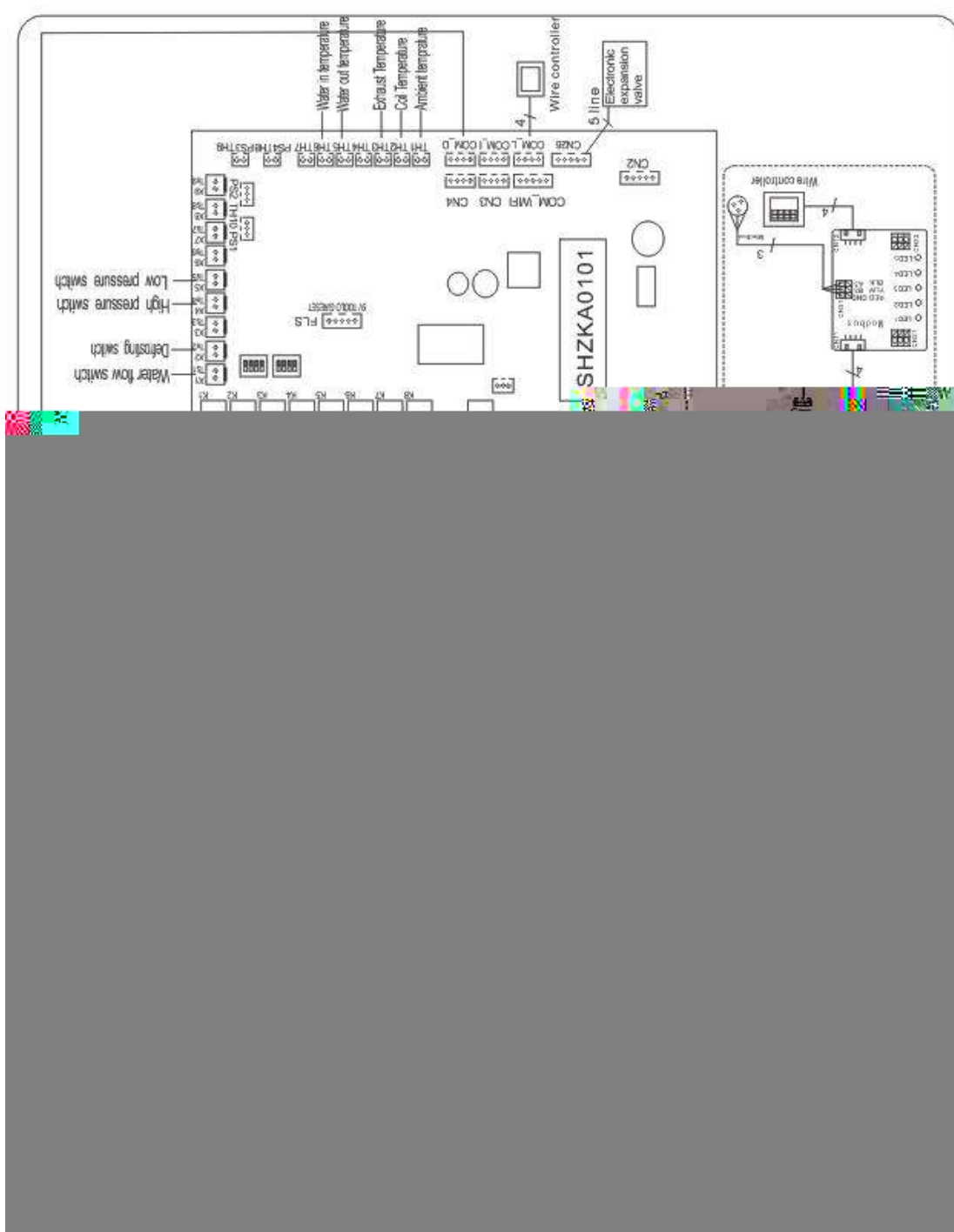

* Above electrical wiring diagram only for your reference, please subject machine posted the wiring diagram.

6.6 Electrical connection

The power supply for the heat pump must come, preferably, from an exclusive circuit with regulatory protection components (30mA differential protection) and a magneto-thermal switch.

- The electrical installation must be carried out by a specialized professional (electrician) in accordance with the standards and regulations in force in the country of installation.
 - The heat pump circuit must be connected to a safety earth circuit at the terminal block.
 - The cables must be properly installed to prevent interference.
 - The pump is intended for connection to a general power supply with earth connection.
 - Section of the cable; This section is indicative and should be checked and adapted according to the needs and conditions of use.
 - The tolerance of acceptable voltage variation is +/- 10% during operation.
- The connections must be dimensioned according to the power of the device and the state of installation.

Models	Circuit breaker	Maximum length of the wire			
		2,5 mm ²	4 mm ²	6 mm ²	10 mm ²
PROELYXP07i	7 A	84 m	135 m	200 m	335 m
PROELYXP09i	9 A	57 m	90 m	130 m	225 m
PROELYXP11i	11A				
PROELYXP14i	14 A	43 m	68 m	100 m	170 m
PROELYXP16i	16 A	34 m	54 m	80 m	135 m
PROELYXP20i	20 A	29 m	45 m	66 m	110 m
PROELYXP26i	26 A	/	25 m	38 m	62 m
PROELYXP30i	35 A	/	/	22 m	36 m
PRO ELYO INVERBOOST NN 26T	9 A	15 m	35 m	49 m	81 m
PRO ELYO INVERBOOST NN 35	34 A	/	/	22 m	36 m
PRO ELYO INVERBOOST NN 35T	13 A	12 m	27 m	39 m	68 m



These values are given as a guideline, only an authorized electrician can determine the values corresponding to your installation.

The electric cable must be equipped with a ground connection and with a circuit breaker with differential 30mA.

6.7 Installation of the display departee

Photo(1)



Photo(2)



Photo(4)



Photo(5)



- The end with plug connects with the control panel (photo1)
- The other end of the signal wire. (photo2)
- Open the cover of the terminal box and pass through it the cable of the remote screen.(photo3,4)
- Insert the wiring into the designated position on the Modbus Module or PCB(without Modbus). (photo5)

6.8 Installation of the Modbus/Fluidra Connect Signal Wire

Photo(6)



Photo(7)



Photo(8)



Photo(9)

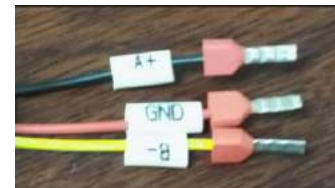

- Open the cover of the terminal box (photo6)
- Take the Modbus/Fluidra Connect signal wire from the accessories (photo7) and put the round end of the signal wire into the signal wire from Modbus/Fluidra Connect Module. (photo 8)
- Three wire terminal :“A+” ,“B- ”, “GND” (Photo 9)

ATTENTION :

Disconnect: A means to disconnect should be located within sight of and readily accessible from the unit(circuit breaker, fused or un-fused switch). This is common practice on commercial and residential heat pumps. It prevents remotely-energizing unattended equipment and permits turning off power at the unit while the unit is being serviced.

Dry contact timer connection

Timer

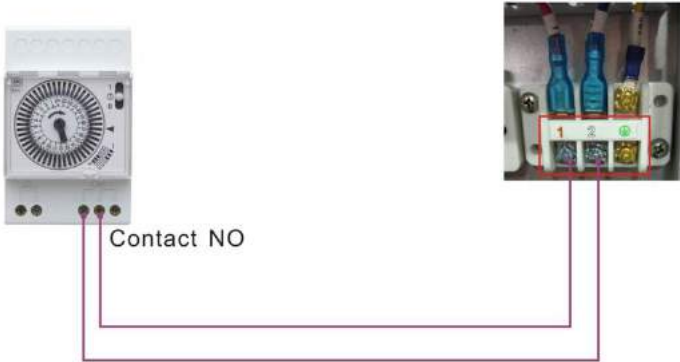

Dry contact pump connection

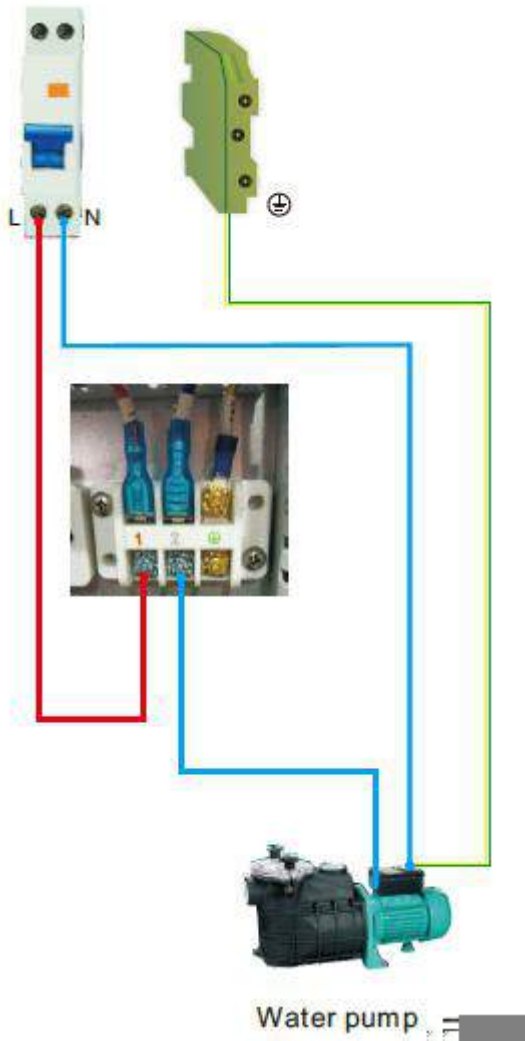

7. Display Controller Operation

7.1. Guide for operation

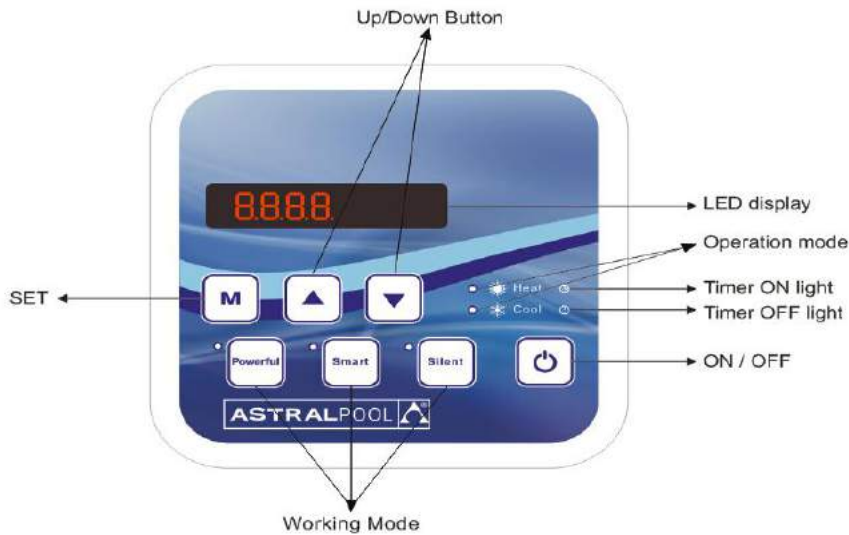



When the heat pump connects to the power, the LED display shows a code for 3 seconds which indicates the heat pump model.

7.2 The keys and their operations

7.2.1 button

Press  to start the heat pump unit, the LED display shows the desired water temperature for 5 seconds, then shows the inlet water temperature and the operation mode.

Press  to stop the heat pump unit and show "OFF"

Notice : During the parameter checking and setting, press the  to quick-exit and save the current setting .



Press  again to turn on/off the machine.

7.2.2 button



Press  for 5 seconds to switch the heating mode and auto mode.

7.2.3 and button



Lock/unlock the display:

Hold  and  for 5 seconds to lock/Unlock the display.

Water temperature setting:

Press  or  to set the water temperature directly.

Parameter checking:

Press  first, then press  to check the User parameter from d0 to d14

Code	Condition	Scope	Remark
d0	IPM mould temperature	0-120°C	Real testing value
d1	Inlet water temp.	-9°C ~99°C	Real testing value
d2	Outlet water temp.	-9°C ~99°C	Real testing value
d3	Ambient temp.	-30°C ~70°C	flash if Real value<-9
d4	Frequency limitation code	0,1,2,4,8,16	Real testing value
d5	Piping temp.	-30°C ~70°C	flash if Real value<-9
d6	Gas exhaust temperature	0°C ~C5°C (125°C)	Real testing value
d7	Step of EEV	0~99	N*5
d8	Compressor running frequency	0~99Hz	Real testing value
d9	Compressor current	0~30A	Real testing value
d10	Current fan speed	0-1200 (rpm)	Real testing value
d11	Error code for last time	All error code	
d12	MOBUS COM	0 - 5	Setting, Modbus Only
d13	MODBUS ID Address	1 - 88	Setting, Modbus Only
d14	Product Code	0000- FFFF	Setting, Modbus Only

Remark:

d4:Frequency limitation code,



0: No frequency limit;

1:Coil pipe temperature limit;

2: Overheating or overcooling frequency limit; 4:Drive Current frequency limit;







8:Drive voltage frequency limit;

16:Drive high temperature frequency limit

Press  first, then press  to check/adjust the User parameter from P1 to P7



Code	Name	Scope	Default	Remark
P0	Mandatory defrosting	0-1	0	0: Default normal operation 1: mandatory defrosting.
P1	Working mode	0-1	1	1:Heating mode, 0:cooling mode,
P2	Timer on/off	0-1	0	1 Timer on/off is under function, 0 Timer on/off is out of function (The setting of P5 and P6 won't work)
P3	Water pump	0-1	0	1:Always running; 0:Depends on the running of compressor
P4	Current time	HH:MM	00: 00	<u>0-23:0-59</u>
P5	Timer on	HH:MM	00: 00	<u>0-23:0-59</u>
P6	Timer off	HH:MM	00: 00	<u>0-23:0-59</u>
P7	Water temp. calibration	-9~9	0	Default setting: 0
P12	MOBUS COM	0 - 5	0	Modbus Only (default value after reset)
P13	MODBUS ID Address	1 - 88	9	Modbus Only (default value after reset)

Code with connect	Parameter P	Description
71676	17FC	PAC PROELYXP07i 7-3.1Kw
71677	17FD	PAC PROELYXP09i 9-2.3Kw
71678	17FE	PAC PROELYXP11i 11-2.9Kw
71679	17FF	PAC PROELYXP14i 14-3.2Kw
71680	1800	PAC PROELYXP16i 16-3.8Kw
71681	1801	PAC PROELYXP20i 20-4.7Kw
71682	1802	PAC PROELYXP26i 26-5.9Kw
71683	1803	PAC PROELYXP30i 30-6.8Kw
68821	0CD5	PAC PROELYO INVERBOOST NN 26T 26-5.9Kw
68822	0CD6	PAC PROELYO INVERBOOST NN 35 35-8Kw
68823	0CD7	PAC PROELYO INVERBOOST NN 35T 35-8Kw

Product code parameter P (Modbus Only): Press  +  for 5 second, the first digital number flashes, press  or  to choose the target number from 0-F, then press  go to adjust the second number. So does the third and fourth number. Lastly press  to save the setting and exit, or it automatically exit after 15 seconds.

After the setting, the product code parameter P couldn't be reset, even if system reset, Its setting value is always retained.

7.2.4 System reset function

Press  and  in 10s, the system will reset and display “0000” on the controller.

7.2.5

Symbol of heating, the light will be on when it is in operation.
When defrosting, the light will flash.

7.2.6

Symbol of cooling, the light will be on when it is in operation.

7.2.7

Symbol of automatic stop, the light will be on when it is in operation.

7.2.8

Symbol of automatic start, the light will be on when it is in operation.

7.2.9

Press this button, the light will be flash, the heat pump will operate in ‘Full output’ only.

7.2.10

While you choose the **Smart**, the heat pump will just operate in ‘Medium output’ and ‘Full output’

When in ‘Medium output’, the lamp of Smart will flash.

When in ‘Full output’, the lamp of Smart is lit, the lamp of Powerful will flash.

7.2.11

While you choose the **Silent**, the heat pump will just operate in ‘Medium output’ and ‘Small output’

When in ‘Small output’, the lamp of Silent will flash.

When in ‘Medium output’, the lamp of Silent is lit, the lamp of Smart will flash.

7.2.12 Auto Mode

There are 3 modes for the unit, Heating only, Auto mode(heating and cooling switch), Cooling only.

You can switch Heating only and Auto mode by pressing **M** for 5 seconds, no matter the unit is on or off.

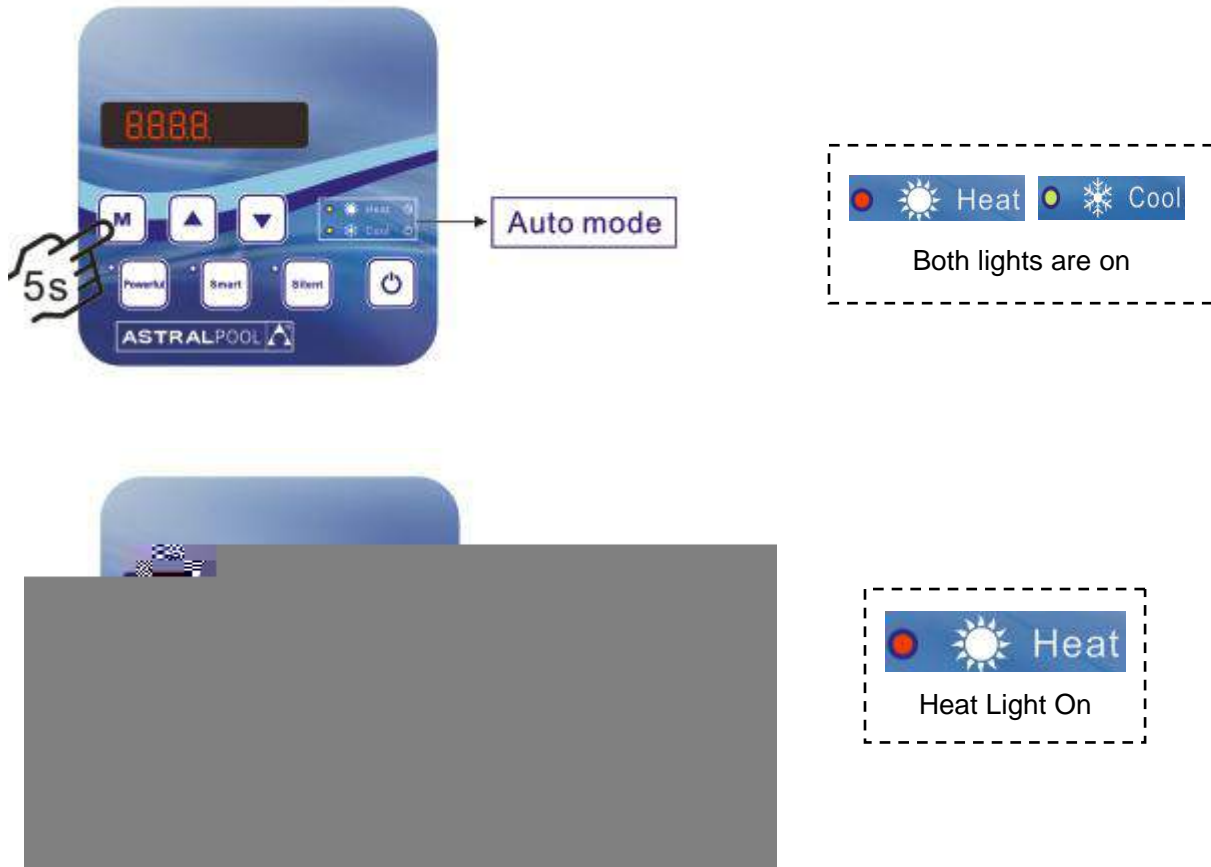

Operation logic of Auto Mode

Option 1 Water pump is related to heat pump operation to start or stop.

Filtration pump starts 60s before compressor, filtration pump start 30s and then the water flow switch detect flow. When the heat pump enters standby mode, filtration pump will stop 60s after compressor stops. Filtration pump will restart running for 3 minutes then stop when the standby time is over 2 hours.

	Condition	Example	Water pump working logic
Heating mode	$T1 > Tset - 1$, last for 30 minutes	$T1 > 27^{\circ}C$, last for 30 minutes	Filtration pump will enter standby mode for 2 hours and will not start except after manual power off and restart. Heat pump will restart 3 minutes after the filtration pump exit the standby mode to detect the water temp. T1 again.
Cooling mode	$T1 < Tset + 1$, last for 30 minutes	$T1 < 29^{\circ}C$, last for 30 minutes	Filtration pump will enter standby mode for 2 hours and will not start except after manual power off and restart. Heat pump will restart 3 minutes after the filtration pump exit the standby mode to detect the water temp. T1 again.

Option 2

When the heat pump is on (running or standby), filtration pump will always be on. It will run for 1 minute after manually turning off.

NOTE :

Tset = Tsetting water temperature

For example : Tset = $28^{\circ}C$ Tsetting water temperature in your pool heat pump

Tset-1 = less $1^{\circ}C$ than Tsetting temperature

Tset- 1 = $28-1=27^{\circ}C$

Tset+1= more $1^{\circ}C$ than Tsetting temperature

Tset+ 1 = $28+1=29^{\circ}C$

7.3 Heating operation logic

Working status		Working mode	Water in temperature-T1	For example , water in temperature-T1	Heat pump working level
1	Start-up of heat pump	When you select the "Smart working mode "	$T1 < Tset-1$	$T1 < 27^{\circ}\text{C}$	Powerful mode-frequency F9
2			$Tset-1 \cong T1 < Tset$	$27^{\circ}\text{C} \cong T1 < 28^{\circ}\text{C}$	Frequency: F9 -F8-F7,...,-F2
3			$Tset \cong T1 < Tset+ 1$	$28^{\circ}\text{C} \cong T1 < 29^{\circ}\text{C}$	Silent mode-frequency F2
4			$T1 \cong Tset+1$	$T1 \cong 29^{\circ}\text{C}$	HP will be in Standby, stop working until the water temperature drops to less 28°C .
5		When you select the "Silent working mode".	$T1 < Tset$	$T1 < 28^{\circ}\text{C}$	Smart mode -frequency F5.
6			$Tset \cong T1 < Tset+1$	$28^{\circ}\text{C} \cong T1 < 29^{\circ}\text{C}$	Silent mode-frequency F2/F1.
7			$T1 \cong Tset+1$	$T1 \cong 29^{\circ}\text{C}$	HP will be in Standby, stop working until the water temperature drops to less 28°C .
8		When you select the "Powerful working mode."	$T1 < Tset+1$	$T1 < 29^{\circ}\text{C}$	Powerful mode-frequency F10/F9
9			$T1 \cong Tset+1$	$T1 \cong 29^{\circ}\text{C}$	HP will be in Standby, stop working until the water temperature drops to less 28°C .
10	Re-start to heat water in standby status	When HP is working at " Smart mode"	$T1 \cong Tset$	$T1 \cong 28^{\circ}\text{C}$	Standby
11			$Tset > T1 \cong Tset-1$	$28^{\circ}\text{C} > T1 \cong 27^{\circ}\text{C}$	Silent-frequency F2
12			$Tset-1 > T1 \cong Tset-2$	$27^{\circ}\text{C} > T1 \cong 26^{\circ}\text{C}$	Frequency: F2 -F3-F4,...,-F9
13			$< Tset-2$	$< 26^{\circ}\text{C}$	Powerful-frequency F9
14		When HP is working at " Silent mode"	$\cong Tset$	$\cong 28^{\circ}\text{C}$	Standby
15			$Tset > T1 \cong Tset-1$	$28^{\circ}\text{C} > T1 \cong 27^{\circ}\text{C}$	Silent mode-frequency F2/F1
16			$T1 < Tset-1$	$T1 < 27^{\circ}\text{C}$	Smart -frequency F5
17	When HP is working at " Powerful mode"	$T1 < Tset-1$	$T1 < 27^{\circ}\text{C}$	Powerful -frequency F10/F9	

7.4 Cooling operation logic

Working status	Working mode	Water in temperature	For example , water in temperature	Heat pump working level	
1	When you select the "Smart working mode "	$T1 \cong Tset-1$	$T1 \cong 27^{\circ}C$	Standby.	
2		$Tset-1 < T1 \cong Tset$	$27^{\circ}C < T1 \cong 28^{\circ}C$	Silent mode-frequency F2	
3		$Tset < T1 \cong Tset+1$	$28 < T1 \cong 29^{\circ}C$	frequency: F9 -F8-F7,...,- F2	
4		$T1 \cong Tset+1$	$T1 \cong 29^{\circ}C$	Powerful mode-F9	
5	Start-up of heat pump When you select the "Silent working mode".	$T1 \cong Tset-1$	$\cong 27^{\circ}C$	Standby	
6		$Tset-1 < T1 \cong Tset$	$27^{\circ}C < T1 \cong 28^{\circ}C$	Silent mode - frequency F2/F1	
7		$T1 > Tset$	$T1 > 28^{\circ}C$	Smart mode -frequency F5	
8	When you select the "Powerful working mode."	$T1 > Tset-1$	$T1 > 27^{\circ}C$	Powerful mode-frequency F10/F9	
9		$T1 \cong Tset-1$	$T1 \cong 27^{\circ}C$	Standby	
10	Re-start to cool water in standby status	Smart	$T1 \cong Tset-1$	$T1 \cong 27^{\circ}C$	Standby
11			$Tset \cong T1 < Tset+1$	$28 \cong T1 < 29^{\circ}C$	Silent- frequency F2
12			$Tset+1 \cong T1 < Tset+2$	$29 \cong T1 < 30^{\circ}C$	Frequency: F2 -F3-F4,...,- F9
13			$T1 \cong Tset+2$	$T1 \cong 30^{\circ}C$	Powerful mode -frequency F9
14	Silent	$Tset < T1 \cong Tset+1$	$28 < T1 \cong 29^{\circ}C$	Silent mode-frequency F2/F1	
15		$T1 > Tset+1$	$T1 > 29^{\circ}C$	Smart mode-frequency F5	
16	Powerful	$T1 > Tset+1$	$T1 > 29^{\circ}C$	Powerful mode-frequency F10/F9	
17		$T1 \cong Tset-1$	$T1 \cong 27^{\circ}C$	Standby	

8.1 Error code display on LED wire controller

Malfunction	Error code	Reason	Solution
Inlet water temperature sensor failure T1-TH6	PP01	1. The sensor in open or short circuit 2. The wiring of sensor is loose	1. Check or change the sensor 2.Re-fix the wiring of the sensors
Outlet water temperature sensor failure T2-TH5	PP02	1. The sensor in open or short circuit 2. The wiring of sensor is loose	1. Check or change the sensor 2.Re-fix the wiring of the sensors
Heating piping sensor failure T3-TH2	PP03	1. The sensor in open or short circuit 2. The wiring of sensor is loose	1. Check or change the sensor 2.Re-fix the wiring of the sensors
Gas return sensor failure	PP04	1. The sensor in open or short circuit 2. The wiring of sensor is loose	1. Check or change the sensor 2.Re-fix the wiring of the sensors
Ambient temperature sensor failure T5-TH1	PP05	1. The sensor in open or short circuit 2. The wiring of sensor is loose	1. Check or change the sensor 2.Re-fix the wiring of the sensors
Exhaust piping sensor failure T6-TH3	PP06	1. The sensor in open or short circuit 2. The wiring of sensor is loose	1. Check or change the sensor 2.Re-fix the wiring of the sensors
Antifreeze protection in Winter	PP07	Ambient temperature or water inlet temperature is too low	Normal protection
Low ambient temperature protection	PP08	1.Beyond the scope of using environment 2. Sensor abnormality	1. Stop using, beyond the scope of using 2.Change the sensor
Piping temperature too high protection under cooling mode T3-TH2	PP10	1. Ambient temperature is too high or the water temperature is too high in cooling mode 2. Refrigeration system is abnormal	1. Check the scope of using 2. Check refrigeration system
T2-TH5 water temp. Too low protection under cooling mode	PP11	1. Low water flow 2. T2-TH5 temperature sensor abnormal	1. Check filtration pump and waterway system 2. Change T2-TH5 temperature sensor
High pressure failure TS4	EE01	1. Ambient temperature is too high 2. Water temperature is too high 3. Water flow is too low Fan motor speed is abnormal or fan motor has damaged	1. Check the water flow or filtration pump 2. Check the fan motor 3. Check and repair the piping system

Malfunction	Error code	Reason	Solution
Low pressure failure TS5	EE02	<ol style="list-style-type: none"> 1. EEV has blocked or pipe system is jammed 2. Motor speed is abnormal or motor has damaged 3. Gas leakage 	<ol style="list-style-type: none"> 1. Check the EEV and piping system Check the motor 2. Through the high pressure gauge to check the pressure value 3. Check refrigeration system
Water flow failure TS1	EE03 Or" ON"	<ol style="list-style-type: none"> 1. Water flow switch is damaged 2. No/ Insufficient water flow. 	<ol style="list-style-type: none"> 1. Change the water flow switch 2. Check the filtration pump or the waterway system
Over heating protection for water temperature (T2-TH5) in heating mode	EE04	<ol style="list-style-type: none"> 1. Low water flow 2. Water flow switch is stuck and the water supply is cut off 3. T2-TH5 sensor is abnormal 	<ol style="list-style-type: none"> 1. Check the water way system 2. Check the filtration pump or water flow switch 3. Check T2-TH5 sensor or replace
T6-TH3 Exhaust too high protection	EE05	<ol style="list-style-type: none"> 1.Lack of gas 2.Low water flow 3.Piping system has been blocked 4.Exhaust temp. Sensor failure 	<ol style="list-style-type: none"> 1. Check the high pressure gauge, if too low, fill with some gas 2. Check the waterway system and filtration pump 3. Check the piping system if there was any block 4. Change a new exhaust temp. sensor
Controller failure	EE06	<ol style="list-style-type: none"> 1. Wire connection is not good, or damaged signal wire 2. Controller failure 	<ol style="list-style-type: none"> 1. Check and re-connect the signal wire 2. Change a new signal wire 3. Turn off electricity supply and restart machine 4. Change anew controller
Compressor current protection	EE07	<ol style="list-style-type: none"> 1. The compressor current is too large instantaneously 2. Wrong connection for compressor phase sequence 3.Compressor accumulations of liquid and oil lead to the current becomes larger 4. Compressor or driver board damaged 5. The water flow is abnormal 6. Power fluctuations within a short time 	<ol style="list-style-type: none"> 1. Check the compressor 2. Check compressor phase 3. Check if the power in the normal range 4. Check the phase sequence connection 5. Check the waterway system and filtration pump 6. Check mains power input

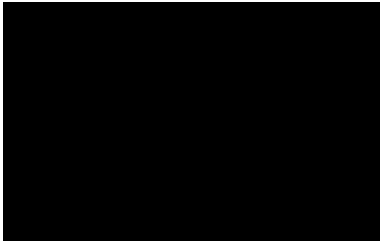
Function	Error Code	Reason	Solution
Communication failure between controller and main board	EE08	<ol style="list-style-type: none"> Poor signal wire connection or damaged signal wire Controller malfunction 	<ol style="list-style-type: none"> Check the connection of the signal wire Change a new signal wire Turn off electricity supply and restart machine Change controller
Communication failure between Main control board and Driving board	EE09	<ol style="list-style-type: none"> Poor connection of communication wire The wire is damaged 	<ol style="list-style-type: none"> Check the wire connection Change wire
VDC voltage too high protection	EE10	<ol style="list-style-type: none"> Line voltage is too high Driver board is damaged. 	<ol style="list-style-type: none"> Check if the power is in the normal range Change driver board or main board
IPM module protection	EE11	<ol style="list-style-type: none"> Data mistake Wrong compressor phase connection Compressor liquid and oil accumulation lead to the current becomes larger Compressor or driver board damaged 	
VDC voltage too low protection	EE12	<ol style="list-style-type: none"> Mother line voltage is too low Driver board is damaged. 	<ol style="list-style-type: none"> Check if the power is in the normal range Change driver board
Input current over high protection.	EE13	<ol style="list-style-type: none"> The compressor current is too large momentary The water flow is abnormal 	

Malfunction	Error code	Reason	Solution
IPM module temperature too high protection	EE15	<ol style="list-style-type: none"> 1. Output exception of IPM module thermal circuit 2. Motor is abnormal or damaged 3. Fan blade is broken 	<ol style="list-style-type: none"> 1. Change a driver board 2. Check if the fan motor speed is too low or fan motor damaged, change it 3. Change the fan blade
PFC module protection	EE16	<ol style="list-style-type: none"> 1. Output exception of PFC module 2. Motor is abnormal or damaged 3. Fan blade is broken 4. Input voltage leap, input power is abnormal 	<ol style="list-style-type: none"> 1. Change a driver board 2. Check if the motor speed is too low or fan motor damaged, change it 3. Change the fan blade 4. Check the input voltage
DC fan motor failure	EE17	<ol style="list-style-type: none"> 1. DC motor is damaged 2. Main board is damaged 3. The fan blade is stuck 	<ol style="list-style-type: none"> 1. Detect DC motor, replace with a new one 2. Change a new main board 3. Find out the barrier and work it out
PFC module thermal circuit is abnormal	EE18	The driver board is damaged	<ol style="list-style-type: none"> 1. Change a new driver board 2. Check if the fan motor speed is too low or fan motor damaged, change it
PFC module high temperature protection	EE19	<ol style="list-style-type: none"> 1. PFC module thermal circuit output abnormal 2. Motor is abnormal or damaged 3. Fan blade is broken 4. The screw in the driver board is not tight 	<ol style="list-style-type: none"> 1. Change a new driver board 2. Check if the motor speed is too low or fan motor damaged, change it 3. Change the fan blade 4. Check if the screw is loose
Input power failure	EE20	The supply voltage fluctuates too much	Check whether the voltage is stable

Malfunction	Error code	Reason	Solution
Software control exception	EE21	<ol style="list-style-type: none"> 1. Compressor runs out of step 2. Wrong program 3. Impurity inside compressor causes the unstable rotate speed 	<ol style="list-style-type: none"> 1. Check the main board or change a new one 2. Enter correct program
Current detection circuit failure	EE22	<ol style="list-style-type: none"> 1. Voltage signal abnormal 2. Driver board is damaged 	<ol style="list-style-type: none"> 1. Check the main board or change a new one 2. Change a new driver board
Compressor start failure	EE23	<ol style="list-style-type: none"> 1. Main board is damaged 2. Compressor wiring error or poor contact or unconnected 3. Liquid accumulation inside 4. Wrong phase connection for compressor 	<ol style="list-style-type: none"> 1. Check the main board or change a new one 2. Check the compressor wiring according to the circuit diagram Check the compressor or change a new one
Ambient Temperature device failure on Driver board	EE24	Ambient Temperature device failure	Change driver board or main board
Compressor phase failure	EE25	Compressors U, V, W are connected to one phase or two phases.	Check the actual wiring according to the circuit diagram
Four-way valve reversal failure	EE26	<ol style="list-style-type: none"> 1. Four-way valve reversal failure 2. Lack of refrigerant (no detect when T3-TH2 or T5-TH1 malfunction) 	<ol style="list-style-type: none"> 1. Switch to Cooling mode to check the 4-way valve if it has been reversed correctly 2. Change a new 4-way valve 3. Fill with gas
EEPROM data read malfunction	EE27	<ol style="list-style-type: none"> 1. Wrong EEPROM data in the program or failed input of EEPROM data 2. Main board failure 	<ol style="list-style-type: none"> 1. Re-enter correct EEPROM data 2. Change a new main board
The inter-chip communication failure on the main control board	EE28	Main board failure	<ol style="list-style-type: none"> 1. Turn off electricity supply and restart it 2. Change a new main board

Remarks:

1. In heating mode, if the water out temperature is higher than the set temperature over 7°C, LED controller displays EE04 for water over-heating protection.
2. In cooling mode, if the water out temperature is lower than the set temperature over 7°C, LED controller displays PP11 for water over-cooling protection.

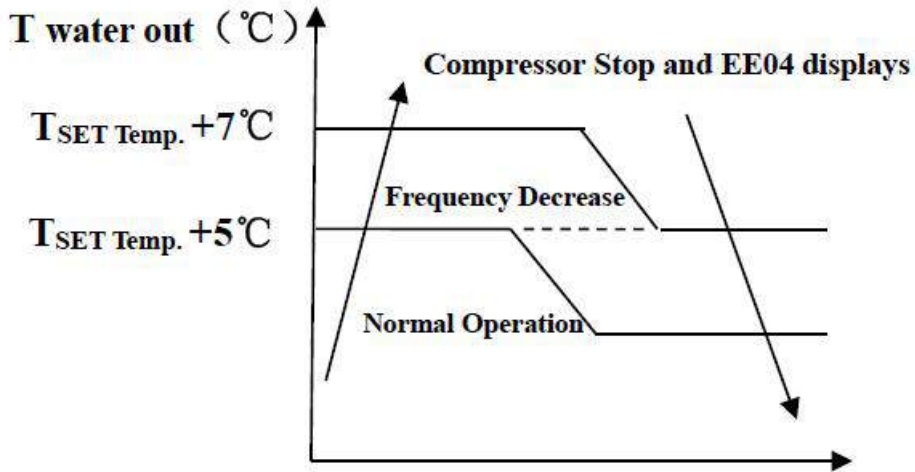

EE04 Water Overheating Protection

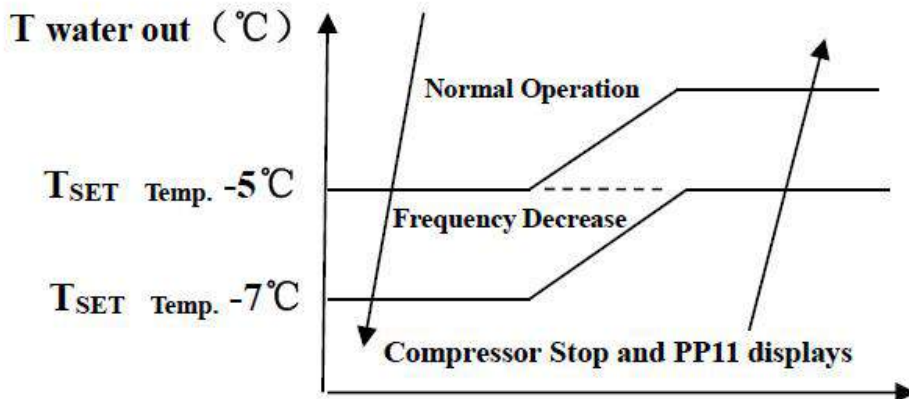

PP11 Water Overcooling Protection

For example as below:

Mode	Output water temperature	Set point temperature	Condition	Malfunction
Heating mode	36°C	29°C	$T_{out} - T_{set} \geq 7^{\circ}\text{C}$	EE04 Overheating protection for water temperature (T2)
Cooling mode	23°C	30°C	$T_{set} - T_{out} \geq 7^{\circ}\text{C}$	PP11 Too low protection for water temperature (T2)

8.2 Other Malfunctions and Solutions (No display on LED wire controller)

Malfunctions	Observing	Reasons	Solution
Heat pump is not running	LED wire controller no display.	No power supply	Check cable and circuit breaker if it is connected
	LED wire controller. Displays the actual time.	Heat pump under standby status	Startup heat pump to run.
	LED wire controller displays the actual water temperature.	<ol style="list-style-type: none"> 1. Water temperature is reaching to setting value, HP under constant temperature status. 2. Heat pump just starts to run. 3. Under defrosting. 	<ol style="list-style-type: none"> 1. Verify water temperature setting. 2. Startup heat pump after a few minutes. 3. LED wire controller should display "Defrosting".
Water temperature is cooling when HP runs under heating mode	LED wire controller displays actual water temperature and no error code displays.	<ol style="list-style-type: none"> 1. Choose the wrong mode. 2. Figures show defects. 3. Controller defect. 	<ol style="list-style-type: none"> 1. Adjust the mode to proper running 2. Replace the defect LED wire controller, and then check the status after changing the running mode, verifying the water inlet and outlet temperature. 3. Replace or repair the heat pump unit
Short running	LED displays actual water temperature, no error code displays.	<ol style="list-style-type: none"> 1. Fan NO running. 2. Air ventilation is not enough. 3. Refrigerant is not enough. 	<ol style="list-style-type: none"> 1. Check the cable connections between the motor and fan, if necessary, it should be replaced. 2. Check the location of heat pump unit, and eliminate all obstacles to make good air ventilation. 3 Replace or repair the heat pump unit.
Water stains	Water stains on heat pump unit.	<ol style="list-style-type: none"> 1. Concreting. 2. Water leakage. 	<ol style="list-style-type: none"> 1. No action. 2. Check the titanium heat exchanger carefully if it is any defect.
Too much ice on evaporator	Too much ice on evaporator.		<ol style="list-style-type: none"> 1. Check the location of heat pump unit, and eliminate all obstacles to make good air ventilation. 2. Replace or repair the heat pump unit.

9. 1 Exploded Diagram

Mode: 71676

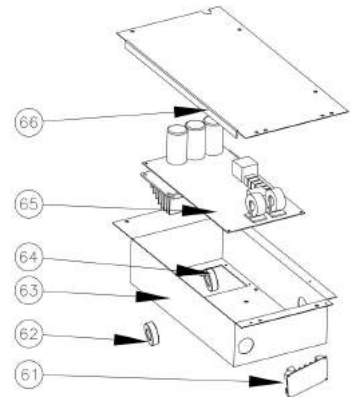
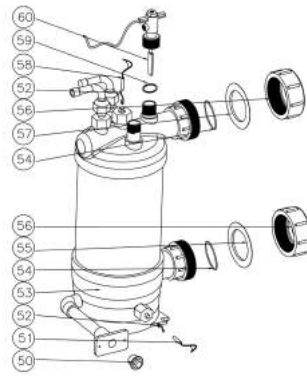
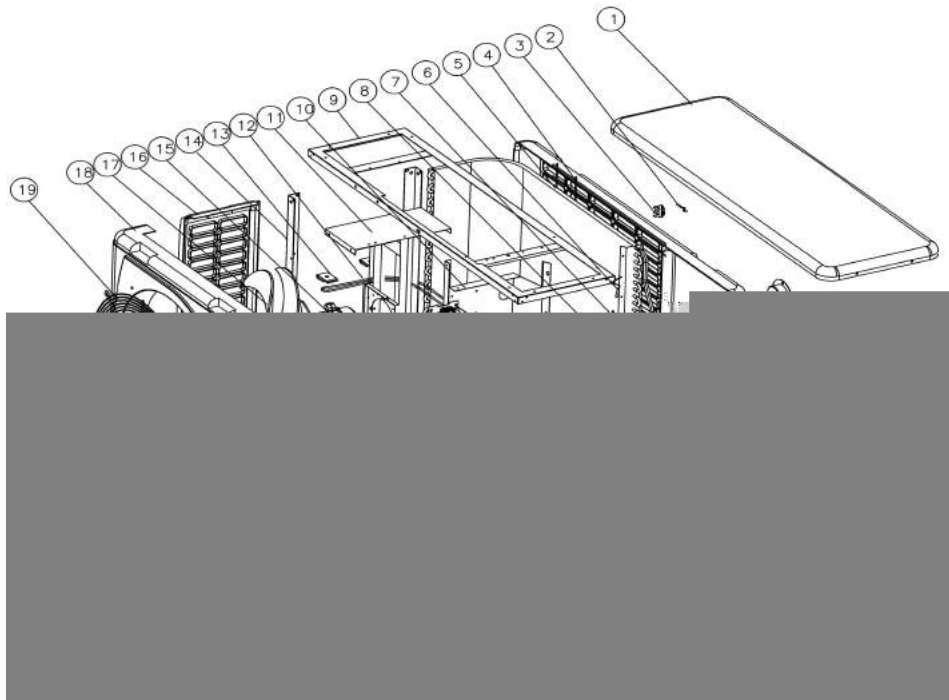

9.2 Spare Parts list

Model : 71676

NO	ERP	Parts name	NO	ERP	Parts name
1	1330900291	Top cover	34	117020180	Controller
2	117110020	Ambient temp. sensor T5-TH1	35	103000227	Evaporator pipe
3	133020010	Ambient temp. sensor clip	36	136020018	Rubber block
4	1330900271	Back panel	37	103000227	Distribution piping
5	103000227	Evaporator	38	106000011	Pressure gauge
6	117110004	Evaporator temperature sensor T3-TH2	39	113020320	Gas return piping
7	113190001	Sensor holder	40	113080074	EEV to distribution piping
8	113190001	Clip	41	113070042	Exchanger to EEV
9	108110038	Top frame	42	119000017	EEV
10	108050073	Isolation panel	43	116000071	Low pressure switch
11	108110043	Fan motor bracket	44	117110021	Discharge temp. sensor T6-TH3
12	142000058	Evaporator heating resistor	45	113010229	Discharge pipe
13	108480015	Evaporator heating resistor support	46	113030081	4-way valve to exchanger
14	108110004	Pillar	47	116000066	High pressure switch
15	112000031	Fan motor	48	113060123	Tube
16	1330900261	Left side panel	49	121000006	4 way valve
17	132000015	Fan blade	50	150000110	Drainage plug
18	1330900251	Front panel	51	117110012	Water inlet temp. sensor T1-TH6
19	108010014	Fan grill	52	108010025	Exchanger temperature sensor clip
20	117230003	Reactor	53	102040705	Titanium heat exchanger
21	101000187	Compressor damping feet	54	133020026	Rubber ring on water connection
22	142000072	Compressor heating resistor	55	133020011	Blue rubber ring
23	101000187	Compressor	56	113900082	Water connection sets
24	113100008	Globe valve support	57	133020011	Red rubber ring
25	120000091	Globe valve	58	117110011	Water outlet temp. sensor T2-TH5
26	180140064	Base tray	59	116000001	Sealing ring
27	108010065	Terminal board	60	112100021-1	Water flow switch
28	115000004	5-ways terminal block	61	117010095	Modbus module
29	113100009	Clip	62	117240002	Magnet ring
30	1330900281	Right panel	63	108110057	Electric box
31	1332500051	Terminal blocks plastic cover	64	117240003	Magnet ring
32	108010018	Wiring box	65	117100046	PCB
33	113712007	Waterproof controller box	66	108050017	Electric box cover

9.3 Model: 71677/71678/71679

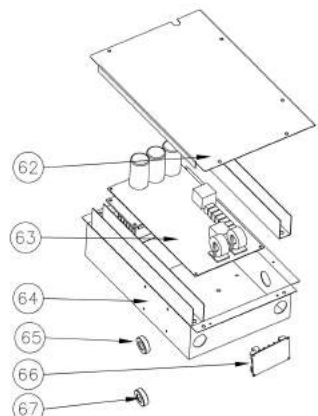
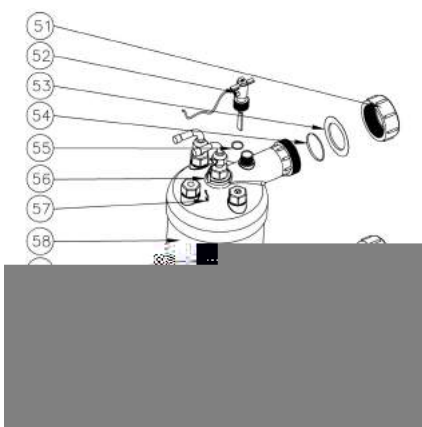
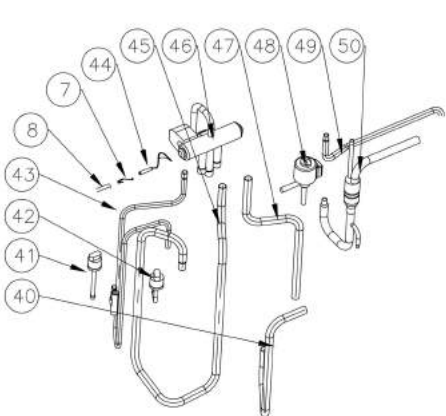
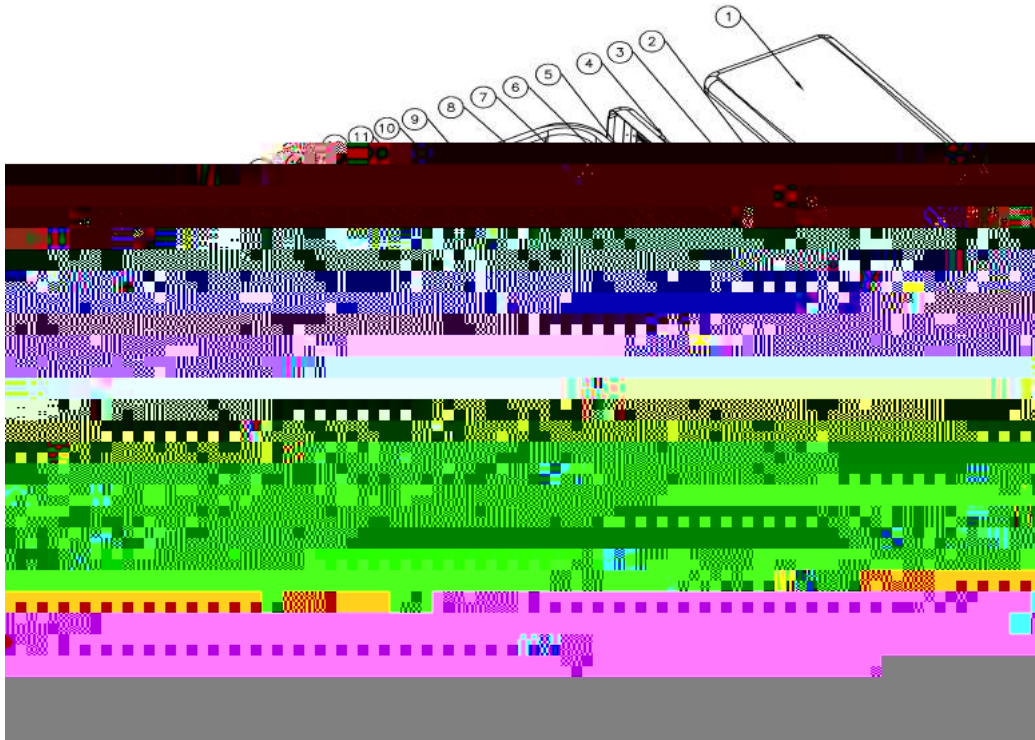

9.4 Spare parts list: 71677

NO	ERP	Parts name	NO	ERP	Parts name
1	1330900291	Top cover	35	113712007	Waterproof controller box
2	117110020	Ambient temp. sensor T5-TH1	36	117020180	Controller
3	133020010	Ambient temp. sensor clip	37	103000221	Evaporator pipe
4	1330900271	Back panel	38	136020005	Rubber block
5	103000221	Evaporator	39	103000221	Distribution piping assembly
6	117110004	Evaporator temperature sensor T3-TH2	40	113030086	4 way valve to exchanger
7	113100009	Clip	41	116000066	High pressure switch
8	113100009	Sensor holder	42	116000071	Low pressure switch
9	108110038	Top frame	43	113010210	Discharge pipe
10	108110043	Fan motor bracket	44	117110021	Discharge temp. sensor T6-TH3
11	117230003	Reactor	45	113020322	Gas return piping
12	108480015	Evaporator heating resistor support	46	121000006	4 way valve
13	108110004	Pillar	47	113060084	4 way valve to collective piping
14	142000079	Evaporator heating resistor	48	119000017	EEV
15	112000031	Fan motor	49	113080054	EEV to distribution piping
16	1330900261	Left side panel	50	113070044	Exchanger to EEV
17	108010024	Fan shaft cover	51	113900082	Water connection sets
18	132000015	Fan blade	52	112100021-1	Water flow switch
19	1330900251	Front panel	53	133020012	Red rubber ring
20	108010014	Fan grill	54	133020026	Rubber ring on water connection
21	108050073	Isolation panel	55	136020083	Sealing ring
22	113100008	Copper pipe	56	117110011	Water outlet temp. sensor T2-TH5
23	120000091	Globe valve	57	108010025	Exchanger temperature sensor clip
24	142000074	Compressor heating resistor	58	102040748	Titanium heat exchanger
25	101000188	Compressor + damping feet	59	133020011	Blue rubber ring
26	101000188	Compressor + damping feet	60	117110012	Water inlet temp. sensor T1-TH6
27	108110066	Base tray	61	150000110	Drainage plug
28	108010065	Terminal Board			

9.5 Spare parts list: 71678

NO	ERP	Parts Name	NO	ERP	Parts Name
1	1330900291	Top cover	35	113712007	Waterproof controller box
2	117110020	Ambient temp. sensor T5-TH1	36	117020180	Controller
3	133020010	Ambient temp. sensor clip	37	103000182	Evaporator pipe
4	1330900271	Back panel	38	136020005	Rubber block
5	103000182	Evaporator	39	103000182	Distribution piping
6	117110004	Evaporator temperature sensor T3-TH2	40	113030086	4-way valve to exchanger
7	113100009	Sensor holder	41	116000066	High pressure switch
8	113100009	Clip	42	116000071	Low pressure switch
9	108110038	Top frame	43	113010210	Discharge pipe
10	108110043	Fan motor bracket	44	117110021	Discharge temp. sensor T6-TH3
11	117230003	Reactor	45	113020322	Gas return piping
12	108480015	Evaporator heating resistor support	46	121000006	4 way valve
13	108110004	Pillar	47	113060084	4-way valve to collective piping
14	142000079	Evaporator heating resistor			

9.6 Spare parts list: 71679

NO	ERP	Parts Name	NO	ERP	Parts Name
1	1330900291	Top cover	35	113712007	Waterproof controller box
2	117110020	Ambient temp. sensor T5-TH1	36	117020180	Controller
3	133020010	Ambient temp. sensor clip	37	103000220	Evaporator pipe
4	1330900271	Back panel	38	136020005	Rubber block
5	103000220	Evaporator	39	103000220	Distribution piping
6	117110004	Evaporator temperature sensor T3-TH2	40	113030081	4-way valve to exchanger
7	113100009	Sensor holder	41	116000066	High pressure switch
8	113100009	Clip	42	116000071	Low pressure switch
9	108110038	Top frame	43	113010159	Discharge pipe
10	108110043	Fan motor bracket	44	117110021	Discharge temp. sensor T6-TH3
11	117230003	Reactor	45	113020321	Gas return piping
12	108480015	Evaporator heating resistor support	46	121000006	4 way valve
13	108110004	Pillar	47	113060084	4-way valve to collective piping
14	142000079	Evaporator heating resistor	48	119000017	EEV
15	112000031	Fan motor	49	113080054	EEV to distribution piping
16	1330900261	Left side panel	50	113070041	Exchanger to EEV
17	108010024	Fan shaft cover	51	113900082	Water connection sets
18	132000015	Fan blade	52	112100021-1	Water flow switch
19	1330900251	Front panel	53	133020012	Red rubber ring
20	108010014	Fan grill	54	133020026	Rubber ring on water connection
21	108050073	Isolation panel	55	116000001	Sealing ring
22	113100008	Globe valve support	56	117110011	Water outlet temp. sensor T2-TH5
23	120000091	Globe Valve	57	108010025	Exchanger temperature sensor clip
24	142000074	Compressor heating resistor	58	102040710	Titanium heat exchanger
25	101000181	Compressor + damping feet	59	133020011	Blue rubber ring
26	101000181	Compressor + damping feet	60	117110012	Water inlet temp. sensor T1-TH6
27	108110044	Base tray	61	150000110	Drainage plug
28	108010065	Terminal Board	62	108050017	Electric box cover
29	133090028	Right panel	63	117100047	PCB
30	106000011	Pressure gauge	64	108110045	Electric box
31	136010004	Clip	65	117240002	Magnet ring
32	115000004	5-ways terminal block	66	117010095	Modbus module
33	1332500051	Terminal blocks plastic cover	67	117240003	Magnet ring
34	133030011	Wiring box			

9.7 Model: 71680/71681

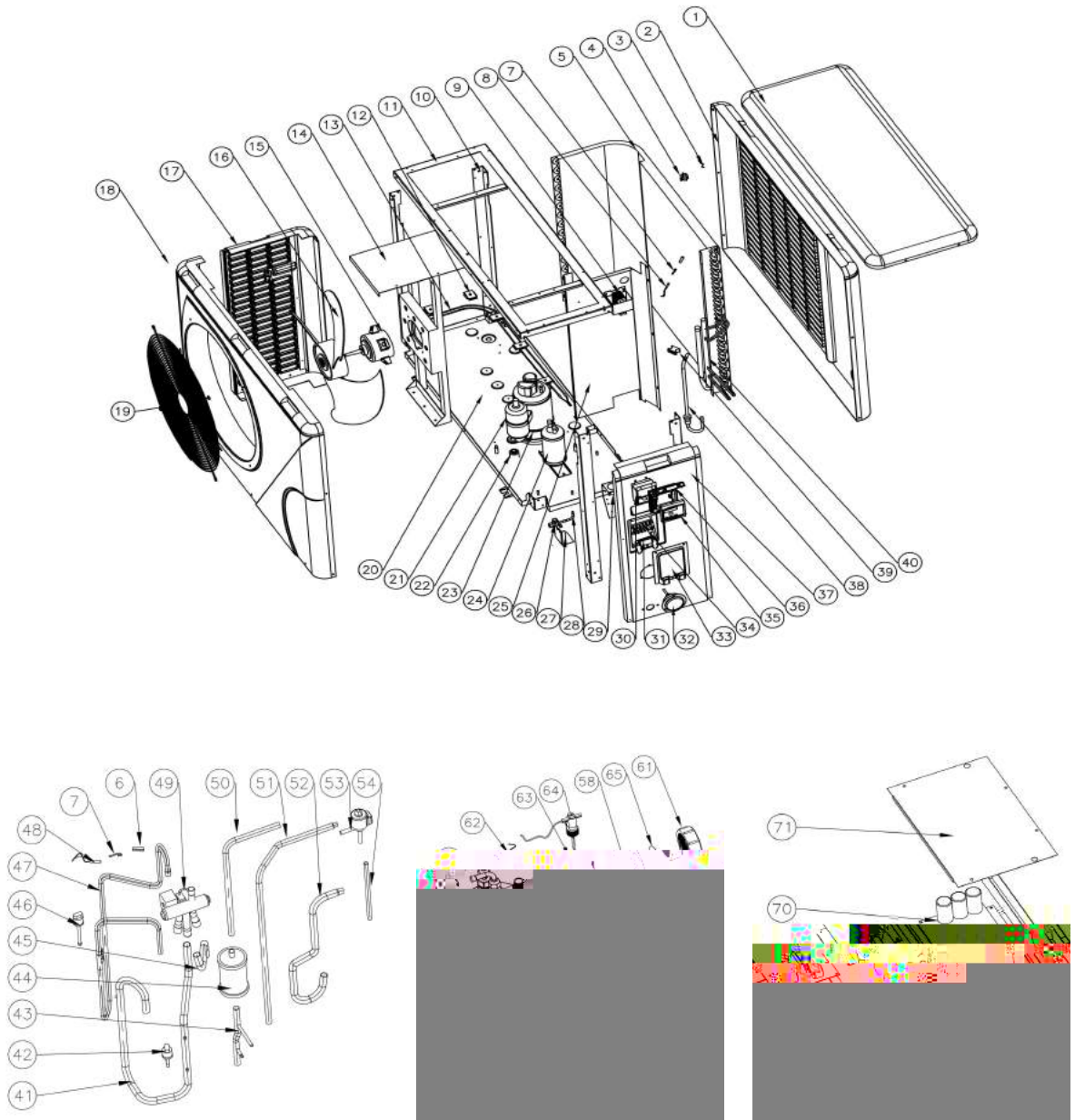

9.8 Spare parts list: 71680

NO	ERP	Spare parts name	NO	ERP	Spare parts name
1	1332600011	Top cover	37	1332600041	Right panel
2	1332600021	Back panel	38	103000230	Distribution piping assembly
3	117110020	Ambient temp. sensor T5-TH1	39	136020005	Rubber block
4	133020010	Ambient temp. sensor clip	40	103000230	Collective piping assembly
5	103000230	Evaporator	41	113020338	Gas return piping
6	113100009	Sensor holder	42	116000073	Low pressure switch
7	113100009	Clip	43	113130021	Pipe to dehydrator filter
8	117110004	Evaporator temperature sensor T3-TH2	44	120000066	Filter
9	117230002	Reactor	45	113060122	4 way valve to collective piping
10	108560003	Pillar	46	116000068	High pressure switch
11	108560002	Top frame	47	113010244	Discharge pipe
12	108480015	Evaporator heating resistor support	48	117110021	Discharge temp. sensor T6-TH3
13	142000079	Evaporator heating resistor	49	121000006	4 way valve
14	108560011	Fan motor bracket	50	113170032	Exchanger to Filter
15	112000031	Fan motor	51	113120019	Pipe to evaporator
16	132000023	Fan blade	52	113030108	4 way valve to exchanger
17	1332600051	Left side panel	53	119000021	EEV
18	1332600031	Front panel	54	113080056	EEV to distribution piping
19	108170017	Fan grill	55	150000110	Drainage plug
20	108560036	Base tray	56	108010025	Exchanger temperature sensor clip
21	101000185	Compressor + damping feet	57	117110012	Water inlet temp. sensor T1-TH6
22	101000185	Compressor + damping feet	58	133020026	Rubber ring on water connection
23	142000077	Compressor Heating resistor	59	133020011	Blue rubber ring
24	105000004	Liquid storage tank	60	102040703	Titanium heat exchanger
25	108560010	Isolation panel	61	113900082	Water connection sets
26	120000091	Globe valve	62	117110011	Water outlet temp. sensor T2-TH5
27	108560034	Globe valve support	63	136020083	Sealing ring
28	113100008	Copper pipe	64	112100021-1	Water flow switch
29	108010065	Terminal Board	65	133020012	Red rubber ring
30	133030011	Wiring box	66	117010095	Modbus module
31	136010004	Clip	67	117240002	Magnet ring
32	106000011	Pressure gauge	68	117240003	Magnet ring
33	1332500051	Terminal blocks plastic cover	69	108560012	Electric box
34	115000004	5-ways terminal block	70	117100048	PCB
35	117020180	Controller	71	108540006	Electric box cover
36	113712007	Waterproof controller box			

9.9 Spare parts list: 71681

NO	ERP	Spare parts name	NO	ERP	Spare parts name
1	1332600011	Top cover	37	1332600041	Right panel
2	1332600021	Back panel	38	103000204	Distribution piping assembly
3	117110020	Ambient temp. sensor T5-TH1	39	136020005	Rubber block
4	133020010	Ambient temp. sensor clip	40	103000204	Evaporator pipe
5	103000204	Evaporator	41	113020339	Gas return piping
6	113100009	Sensor holder	42	116000073	Low pressure switch
7	113100009	Clip	43	113130021	Pipe to dehydrator filter
8	117110004	Evaporator temperature sensor T3-TH2	44	120000066	Dehydrator filter
9	117230002	Reactor	45	113060096	4 way valve to collective piping
10	108560003	Pillar	46	116000068	High pressure switch
11	108560002	Top frame	47	113010245	Discharge pipe
12	108480015	Evaporator heating resistor support	48	117110021	Discharge temp. sensor T6-TH3
13	142000144	Evaporator heating resistor	49	121000009	4 way valve
14	108560011	Fan motor bracket	50	113170032	Dehydrator filter pipe
15	112000031	Fan motor	51	113120019	Pipe to evaporator
16	132000023	Fan blade	52	113030093	4 way valve to exchanger
17	1332600051	Left side panel	53	119000021	EEV
18	1332600031	Front panel	54	113080056	EEV to distribution piping
19	108170017	Fan grill	55	150000110	Drainage plug
20	108560036	Base tray	56	108010025	Exchanger temperature sensor clip
21	101000185	Compressor + damping feet	57	117110012	Water inlet temp. sensor T1-TH6
22	101000185	Compressor + damping feet	58	133020026	Rubber ring on water connection
23	142000077	Compressor Heating resistor	59	133020011	Blue rubber ring
24	105000004	Liquid storage tank	60	102040764	Titanium heat exchanger
25	108560010	Isolation panel	61	113900082	Water connection sets
26	120000091	Globe valve	62	117110011	Water outlet temp. sensor T2-TH5
27	108560034	Globe valve board	63	136020083	Sealing ring
28	113100008	Copper pipe	64	112100021-1	Water flow switch
29	108010065	Terminal Board	65	133020012	Red rubber ring
30	133030011	Wiring box	66	117010095	Modbus module
31	136010004	Clip	67	117240002	Magnet ring
32	106000011	Pressure gauge	68	117240003	Magnet ring
33	1332500051	Terminal blocks plastic cover	69	108560012	Electric box
34	115000004	5-ways terminal block	70	117100048	PCB
35	117020180	Controller	71	108540006	Electric box cover
36	113712007	Waterproof controller box			

9.10 Model: 71682,71683

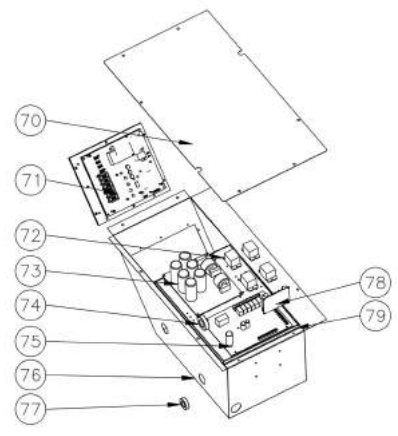
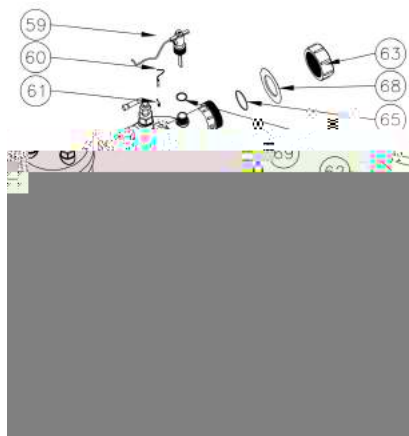
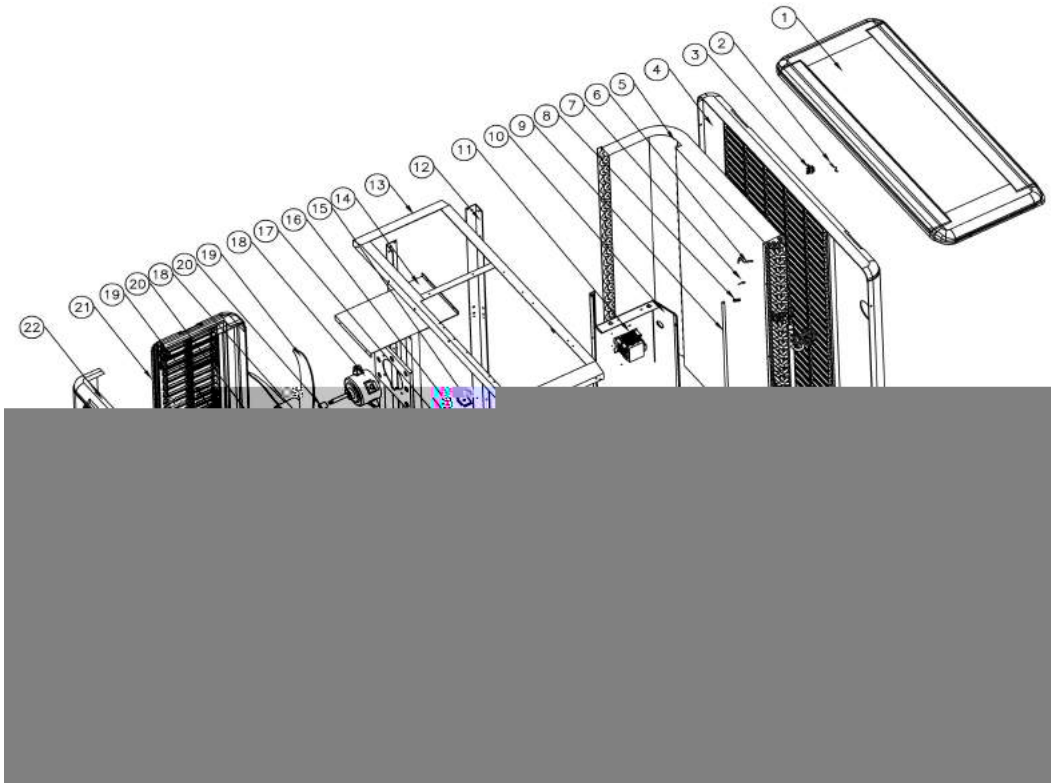

9.11 Spare parts list: 71682

NO	ERP	Parts name	NO	ERP	Parts name
1	133100001	Top cover	41	117020180	Controller
2	117110020	Ambient temp. sensor T5-TH1	42	113712007	Waterproof controller box
3	133020010	Ambient temp. sensor clip	43	103000208	Evaporator pipe
4	133250003	Back panel	44	136020005	Rubber block
5	103000208	Evaporator	45	113020326	Gas return piping
6	117110004	Evaporator temperature sensor T3-TH2	46	116000073	Low pressure switch
7	113100009	Clip	47	113060083	4 way valve to collective piping
8	113100009	Sensor holder	48	113010227	Discharge pipe
9	103000208	Distribution piping	49	113030087	4 way valve to exchanger
10	108120036	Isolation panel	50	121000009	4 way valve
11	117230001	Reactor	51	116000008	High pressure switch
12	108120035	Pillar	52	117110021	Discharge temp. sensor T6-TH3
13	108120034	Top frame	53	113120020	Pipe to evaporator
14	108120044	Fan motor bracket	54	113130020	Pipe to dehydrator filter
15	108480015	Evaporator heating resistor support	55	113080055	EEV to distribution piping
16	142000079	Evaporator heating resistor	56	119000021	EEV
17	108550009	Pillar	57	120000066	Dehydrator filter
18	112000031	Fan motor	58	113170028	Dehydrator filter pipe
19	132000015	Fan blade	59	112100021-1	Water flow switch
20	108010024	Fan shaft cover	60	117110011	Water outlet temp. sensor T2-TH5
21	133250004	Left side panel	61	108010025	Exchanger temperature sensor clip
22	133250001	Front panel	62	102040749	Titanium heat exchanger
23	108010014	Fan grill	63	113900082	Water connection sets
24	120000091	Globe valve	64	133020012	Blue rubber ring
25	113100008	Copper pipe	65	133020026	Rubber ring on water connection
26	101000185	Compressor + damping feet	66	117110012	Water inlet temp. sensor T1-TH6
27	101000185	Compressor + damping feet	67	150000110	Drainage plug
28	105000008	Liquid storage tank	68	133020011	Red rubber ring
29	142000077	Compressor Heating resistor	69	136020083	Sealing ring
30	108550005	Base tray	70	108120040	Electric box cover
31	108550008	Handle pillar	71	117140016	Driver board
32	108010065	Terminal Board	72	142000038	Relay
33	133250002	Right panel	73	117260001	Filter board
34	115000025	3-ways terminal for electricity	74	117240002	Magnet ring
35	106000011	Pressure gauge	75	117250007	PCB
36	136010004	Clip	76	108120038	Electric box
37	108550006	Pillar	77	117240003	Magnet ring
38	115000027	3-ways terminal for filtration pump	78	117010095	Modbus module
39	133250005	Terminal blocks plastic cover	79	108120039	Scale board
40	133030011	Wiring box			

9.12 Spare parts list: 71683

NO	ERP	Parts name	NO	ERP	Parts name
1	133100001	Top cover	41	117020180	Controller
2	117110020	Ambient temp. sensor T5-TH1	42	113712007	Waterproof controller box
3	133020010	Ambient temp. sensor clip	43	103000209	Evaporator pipe
4	133250003	Back panel	44	136020005	Rubber block
5	103000209	Evaporator	45	113020389	Gas return piping
6	117110004	Evaporator temperature sensor T3-TH2	46	116000073	Low pressure switch
7	113100009	Clip	47	113060083	4 way valve to collective piping
8	113100009	Sensor holder	48	113010228	Discharge pipe
9	103000209	Distribution piping	49	113030087	4 way valve to exchanger
10	108120036	Isolation panel	50	121000009	4 way valve
11	117230001	Reactor	51	116000008	High pressure switch
12	108120035	Pillar	52	117110021	Discharge temp. sensor T6-TH3
13	108120034	Top frame	53	113120020	Pipe to evaporator
14	108120044	Fan motor bracket	54	113130020	Pipe to dehydrator filter
15	108480015	Evaporator heating resistor support	55	113080055	EEV to distribution piping
16	142000079	Evaporator heating resistor	56	119000042	EEV
17	108550009	Pillar	57	120000066	Dehydrator filter
18	112000031	Fan motor	58	113170028	Dehydrator filter pipe
19	132000015	Fan blade	59	112100021-1	Water flow switch
20	108010024	Fan shaft cover	60	117110011	Water outlet temp. sensor T2-TH5
21	133250004	Left side panel	61	108010025	Exchanger temperature sensor clip
22	133250001	Front panel	62	102040754	Titanium heat exchanger
23	108010014	Fan grill	63	113900082	Water connection sets
24	120000091	Globe valve	64	133020012	Blue rubber ring
25	113100008	Copper pipe	65	133020026	Rubber ring on water connection
26	101000186	Compressor + damping feet	66	117110012	Water inlet temp. sensor T1-TH6
27	101000186	Compressor + damping feet	67	150000110	Drainage plug
28	105000008	Liquid storage tank	68	133020011	Red rubber ring
29	142000077	Compressor Heating resistor	69	136020083	Sealing ring
30	108470069	Base tray	70	108120040	Electric box cover
31	108550008	Handle pillar	71	117140016	Driver board
32	108010065	Terminal Board	72	142000038	Relay
33	133250002	Right panel	73	117260001	Filter board
34	115000025	3-ways terminal for electricity	74	117240002	Magnet ring
35	106000011	Pressure gauge	75	117250007	PCB
36	136010004	Clip	76	108120038	Electric box
37	108550006	Pillar	77	117240003	Magnet ring
38	115000027	3-ways terminal for filtration pump	78	117010095	Modbus module
39	133250005	Terminal blocks plastic cover	79	108120039	Scale board
40	133030011	Wiring box			

9.13 Model: 68821/68822/68823

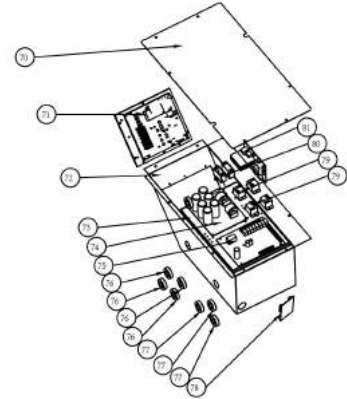
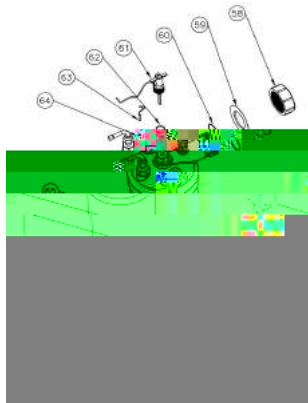
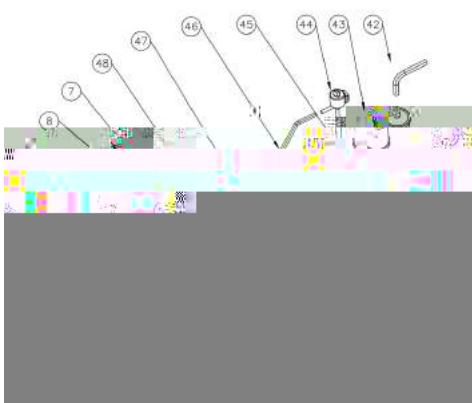
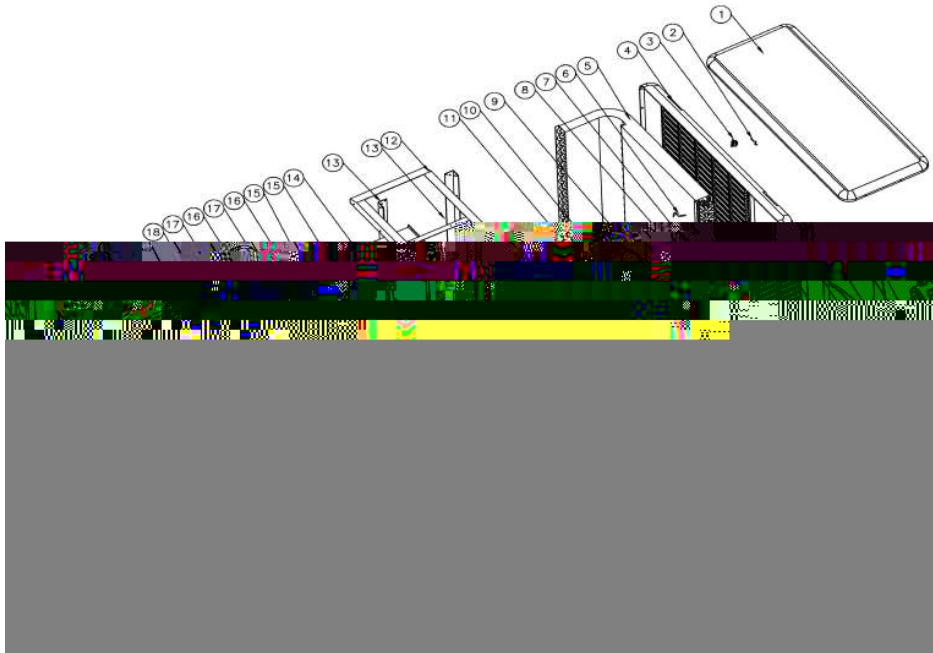

9.14 Spare parts list: 68821

NO	ERP	Parts Name	NO	ERP	Parts Name
1	133100001	Top cover	41	113050109	Evaporator pipe
2	117110020	Ambient temp. sensor T5-TH1	42	113170028	Dehydrator filter pipe
3	133020010	Ambient temp. sensor clip	43	120000066	Dehydrator filter
4	133250003	Back panel	44	119000022	EEV
5	103000153	Evaporator	45	113080055	EEV to distribution piping
6	117110004	Evaporator temperature sensor T3-TH2	46	113120020	Pipe to evaporator
7	113190001	Clip	47	113030087	4 way valve to exchanger
8	113190001	Sensor holder	48	117110021	Discharge temp. sensor T6-TH3
9	113040101	Distribution piping	49	116000008	High pressure switch
10	108550010	Isolation panel	50	121000009	4 way valve
11	117230002	Reactor	51	120000023	Suction valve
12	108120034	Top frame	52	113010158	Discharge pipe
13	108120035	Pillar	53	116000080	Low pressure switch 0.2-0.35
14	108120037	Fan motor bracket	54	116000079	Low pressure switch 0.1-0.3
15	112000031	Fan motor	55	113020245	Gas return piping
16	108010024	Fan motor pipe cover	56	113060083	4-way valve to collective piping
17	132000015	Fan blade	57	113130015	Pipe to dehydrator filter
18	133250004	Left side panel	58	113900082	Water connection sets
19	133250001	Front panel	59	133020011	Red rubber ring
20	108010014	Fan grill	60	133020026	Rubber ring on water connection
21	108550009	Pillar	61	112100021-1	Water flow switch
22	108550005	Base tray	62	116000001-2	Sealing ring
23	101000149	Compressor + damping feet	63	117110011	Water outlet temp. sensor T2-TH5
24	105000008	Liquid storage tank	64	108010025	Exchanger temperature sensor clip
25	142000077	Compressor Heating resistor	65	113900082	Water connection sets
26	101000149	Compressor + damping feet	66	133020012	Blue rubber ring
27	108550008	Handle pillar	67	102040503	Titanium heat exchanger
28	108010065	Terminal Board	68	117110012	Water inlet temp. sensor T1-TH6
29	110000008	Wire connection	69	150000110	Drainage plug
30	108010018	Wiring box	70	108120040	Electric box cover
31	133250002	Right panel	71	117140003	Driver board
32	115000025	3-ways terminal for electricity	72	108120038	Electric box
33	110800001	Pressure gauge	73	108120039	Scale board
34	136010004	Clip	74	117260002	Filter board
35	108550006	Pillar	75	117250001-V1.5	PCB
36	115000027	3-ways terminal for filtration pump	76	117240002	Magnet ring
37	133250005	Terminal blocks plastic cover	77	117240003	Magnet ring
38	113712007	Waterproof controller box	78	117010095	Modbus module
39	117020150	Controller	79	142000038	Relay
40	136020005	Rubber block	80	N/A	N/A
			81	117140006	Fan motor driver board

9.15 Spare parts list: 68822

NO	ERP	Parts Name	NO	ERP	Parts Name
1	133100001	Top cover	41	113050110	Evaporator pipe
2	117110020	Ambient temp. sensor T5-TH1	42	113170028	Dehydrator filter pipe
3	133020010	Ambient temp. sensor clip	43	120000066	Dehydrator filter
4	133250003	Back panel	44	119000022	EEV
5	103000154	Evaporator	45	113080055	EEV to distribution piping
6	117110004	Evaporator temperature sensor T3-TH2	46	113120020	Pipe to evaporator
7	113190001	Clip	47	113030087	4 way valve to exchanger
8	113190001	Sensor holder	48	117110021	Discharge temp. sensor T6-TH3
9	113040102	Distribution piping	49	116000008	High pressure switch
10	108550010	Isolation panel	50	121000009	4 way valve
11	117230004	Reactor	51	120000023	Suction valve
12	108120034	Top frame	52	113010158	Discharge pipe
13	108120035	Pillar	53	116000080	Low pressure switch 0.2-0.35
14	108120037	Fan motor bracket	54	116000079	Low pressure switch 0.1-0.3
15	112000031	Fan motor	55	113020245	Gas return piping
16	108010024	Fan motor pipe cover	56	113060083	4-way valve to collective piping
17	132000015	Fan blade	57	113130015	Pipe to dehydrator filter
18	133250004	Left side panel	58	113900082	Water connection sets
19	133250001	Front panel	59	133020011	Red rubber ring
20	108010014	Fan grill	60	133020026	Rubber ring on water connection
21	108550009	Pillar	61	112100021-1	Water flow switch
22	108550005	Base tray	62	116000001-2	Sealing ring
23	101000122	Compressor + damping feet	63	117110011	Water outlet temp. sensor T2-TH5
24	105000008	Liquid storage tank	64	108010025	Exchanger temperature sensor clip
25	142000077	Compressor Heating resistor	65	113900082	Water connection sets
26	101000122	Compressor + damping feet	66	133020012	Blue rubber ring
27	108550008	Handle pillar	67	102040502	Titanium heat exchanger
28	108010065	Terminal Board	68	117110012	Water inlet temp. sensor T1-TH6
29	110000008	Wire connection	69	150000110	Drainage plug
30	108010018	Wiring box	70	108120040	Electric box cover
31	133250002	Right panel	71	117140002	Driver board
32	115000025	3-seat terminal for electricity	72	108120038	Electric box
33	110800001	Pressure gauge	73	108120039	Scale board
34	136010004	Clip	74	117260001	Filter board
35	108550006	Pillar	75	117250001-V1.5	PCB
36	115000027	3-ways terminal for filtration pump	76	117240002	Magnet ring
37	133250005	Terminal blocks plastic cover	77	117240003	Magnet ring
38	113712007	Waterproof controller box	78	117010095	Modbus module
39	117020150	Controller	79	142000038	Relay
40	136020005	Rubber block	80	N/A	N/A
			81	N/A	N/A

9.16 Spare parts list: 68823

NO	ERP	Parts Name	NO	ERP	Parts Name
1	133100001	Top cover	41	113050110	Collective piping
2	117110020	Ambient temp. sensor T5-TH1	42	113170028	Degydrator filter pipe
3	133020010	Ambient temp. sensor clip	43	120000066	Dehydrator filter
4	133250003	Back panel	44	119000022	EEV
5	103000154	Evaporator	45	113080055	EEV to distribution piping
6	117110004	Evaporator temperature sensor T3-TH2	46	113120020	Pipe to evaporator
7	113190001	Clip	47	113030087	4 way valve to exchanger
8	113190001	Sensor holder	48	117110021	Discharge temp. sensor T6-TH3
9	113040102	Distribution piping	49	116000008	High pressure switch
10	108550010	Isolation panel	50	121000009	4 way valve
11	117230002	Reactor	51	120000023	Suction valve
12	108120034	Top frame	52	113010158	Discharge pipe
13	108120035	Pillar	53	116000080	Low pressure switch 0.2-0.35
14	108120037	Fan motor bracket	54	116000079	Low pressure switch 0.1-0.3
15	112000031	Fan motor	55	113020245	Gas return piping
16	108010024	Fan motor pipe cover	56	113060083	4-way valve to collective piping
17	132000015	Fan blade	57	113130015	Pipe to dehydrator filter
18	133250004	Left side panel	58	113900082	Water connection sets
19	133250001	Front panel	59	133020011	Red rubber ring
20	108010014	Fan grill	60	133020026	Rubber ring on water connection
21	108550009	Pillar	61	112100021-1	Water flow switch
22	108550005	Base tray	62	116000001-2	Sealing ring
23	101000149	Compressor + damping feet	63	117110011	Water outlet temp. sensor T2-TH5
24	105000008	Liquid storage tank	64	108010025	Exchanger temperature sensor clip
25	142000077	Compressor Heating resistor	65	113900082	Water connection sets
26	101000149	Compressor + damping feet	66	133020012	Blue rubber ring
27	108550008	Handle pillar	67	102040502	Titanium heat exchanger
28	108010065	Terminal Board	68	117110012	Water inlet temp. sensor T1-TH6
29	110000008	Wire connection	69	150000110	Drainage plug
30	108010018	Wiring box	70	108120040	Electric box cover
31	133250002	Right panel	71	117140003	Driver board
32	115000006	3-ways terminal for electricity	72	108120038	Electric box
33	110800001	Pressure gauge	73	108120039	Scale board
34	136010004	Clip	74	117260002	Filter board
35	108550006	Pillar	75	117250001-V1.5	PCB
36	115000027	3-ways terminal for water pump	76	117240002	Magnet ring
37	133250005	Terminal blocks plastic cover	77	117240003	Magnet ring
38	113712007	Waterproof controller box	78	117010095	Modbus module
39	117020150	Controller	79	142000038	Relay
40	136020005	Rubber block	80	N/A	N/A
			81	117140006	Fan motor driver board

9.17 Maintenance

- (1) You should check the water supply system regularly to avoid air entering the system and creation of low water flow, because it would reduce the performance and reliability of HP unit.
- (2) Clean your pools and filtration system regularly to avoid the damage of the unit.
- (3) Only a qualified technician is authorized to operate the cooling system pressure. You should drain the water from the heat pump if it will stop running for a long time (especially during the winter season or when the ambient temperature drops below 0°C).
- (4) Check the water levels before the unit start after a long break in usage.
- (5) When the unit is running, there will be condensate water discharging from the bottom of the unit. This is normal.
- (6) Action of filling gas must be conducted by professional with R32 operating license.
- (7) Please fill the R32 gas from the globe valve inside machine.



5. Manuel de l'unité
6. Câblage électrique
7. Mise en service initiale de l'unité
8. Guide de dépannage
9. Schéma éclaté et entretien

Nous vous remercions d'avoir choisi la pompe à chaleur de piscine PRO ELYO INVERBOOST NN pour votre piscine. Elle va chauffer l'eau de votre piscine et la maintenir à une température constante lorsque la température ambiante varie de -20 à 50°C.

Nous avons accordé notre plus grande attention à la réalisation de ce manuel afin que vous puissiez mettre en œuvre votre pompe à chaleur dans de bonnes conditions. Malgré cela, si vous avez besoin d'aide, notre service technique, se tient à votre disposition.

⚠ ATTENTION : Ce manuel contient toutes les informations nécessaires à l'utilisation et à l'installation de votre pompe à chaleur.

L'installateur doit lire le manuel et suivre attentivement les instructions d'utilisation, de mise en œuvre et de sécurité du produit.

L'installateur est responsable de l'installation de l'appareil, du respect des instructions du fabricant et de la réglementation en vigueur. Le non-respect de ce manuel implique l'exclusion de toute garantie.

Le fabricant décline toute responsabilité des dommages occasionnés aux personnes, objets et des erreurs dues à l'installation dans de mauvaises conditions.

Toute utilisation à des fins non conformes à celles qui sont à l'origine de sa fabrication sera considérée comme dangereuse.

⚠ ALERTE

- * Vous devez vidanger l'eau de pompe à chaleur pour empêcher les dommages du gel au cours de l'hiver ou pendant une longue période d'inactivité.
- * Coupez systématiquement l'alimentation électrique lorsque vous intervenez et/ou ouvrez l'unité.
- * Veuillez maintenir, s'il vous plaît, le contrôleur dans

1.1 Composition du colis

Pour la mise en œuvre, vous trouverez avec votre pompe à chaleur, les composants suivants :

- Raccords hydrauliques sortie / entrée en 50 mm (Qté : 2)
- Manuel d'installation et d'utilisation
- Raccords d'évacuation des condensats
- Câble de 10 mètres pour déporter la commande
- Capot de protection pour la protection de la commande déportée
- Housse pour l'hivernage
- Patins anti-vibration (Qté : 4)

1.2 Dimension

Modes: 71676

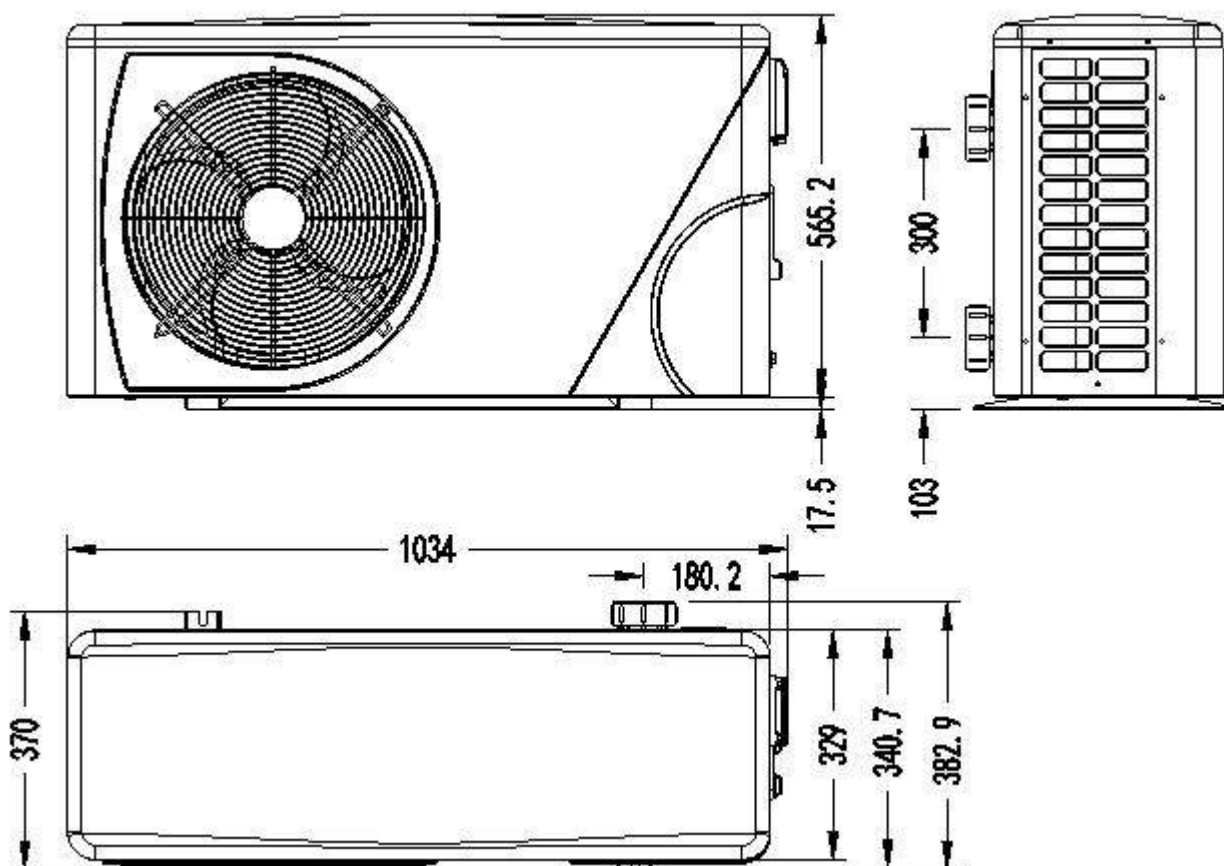

Modes: 71677/71678/71679

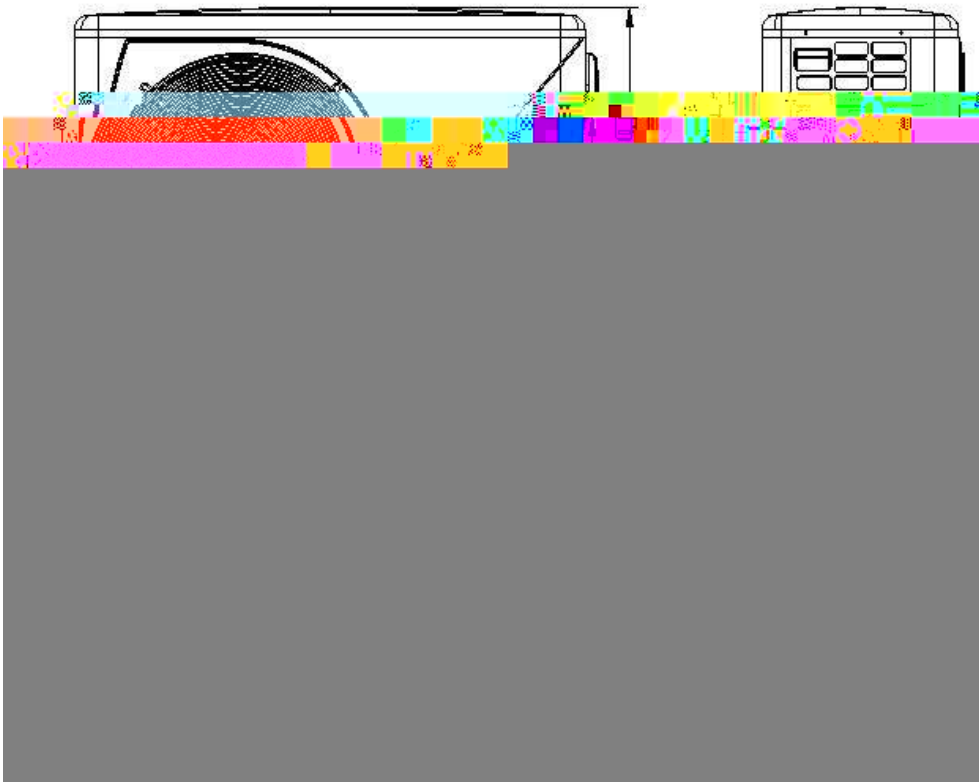

Modes: 71680/71681

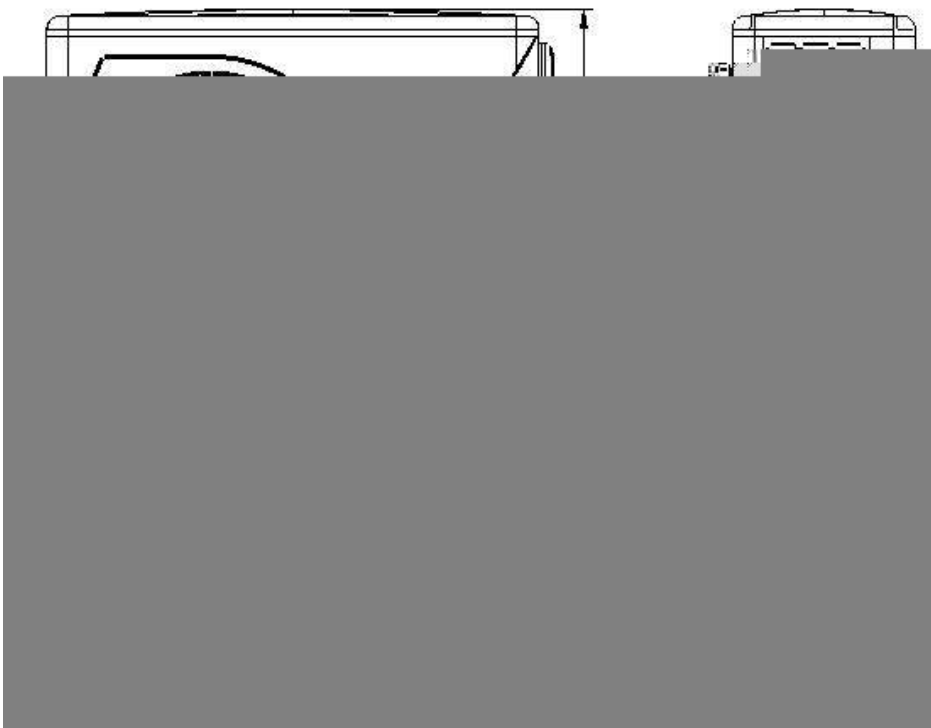

Modes: 71682/71683/68821/68822/68823



Pour le transport
Afin d'éviter les
Même si le transport
acheminement
livraison. Le
trans

su
re tr
eur
bilité de desti
écrites la récep
ll re **PAS OUI**

2.2 Cor

Pompe à chaleur pour piscine PRO ELYO INVERBOOST NN

CE Standard, R32

Modes		PROELYXP07i	PROELYXP09i	PROELYXP11i	PROELYXP14i
Codes		71676	71677	71678	71679
* Puissance de chauffage Air 28°C / Eau 28°C / Humidité 80%					
Chauffage	Kw	7-3.1	9-2.3	11-2.9	14-3.2
Consommation d'énergie	Kw	1.04-0.21	1.34-0.14	1.64-0.18	2.09-0.2
C.O.P.		15-6.7	16-6.7	16-6.7	16-6.7
* Puissance de chauffage Air 15°C / Eau 26°C / Humidité 70%					
Chauffage	Kw	4.7-2.5	6.6-1.9	7.9-2	9.5-2.3
Consommation d'énergie	Kw	0.94-0.32	1.32-0.24	1.58-0.25	1.9-0.29
C.O.P.		7.9-5	8.0-5	8.0-5	8.0-5
* Puissance de chauffage Air 0°C / Eau 26°C / Humidité 78%					
Chauffage	Kw	3.44-1.7	4.11-2.3	5.54-3.0	6.85-3.8
Consommation d'énergie	Kw	1.23-0.38	1.47-0.82	1.98-0.68	2.45-0.85
C.O.P.		4.5-2.8	4.4-2.8	4.4-2.8	4.5-2.8
* Puissance de chauffage Air -10°C / Eau 26°C / Humidité 78%					
Chauffage	Kw	2.41-1.5	3.13-2.0	3.87-2.7	5.1-3.15
Consommation d'énergie	Kw	1.21-0.35	1.42-0.53	1.76-0.69	2.32-0.81
C.O.P.		4.3-2	3.8-2.2	3.9-2.2	3.9-2.2
* Données générales					
Marque du compresseur		MITSUBISHI INVERTER COMPRESSOR			
Alimentation électrique	V	220-240V/50Hz or 60Hz/1PH			
Courant Maximal	A	4.6	5.9	7.2	9.2
Disjoncteur	A	7	9	11	14
Volume de bassin recommandé	m ³	10-26	12-35	16-60	18-66
Débit d'eau préconisé	m ³ /h	2.5	3.0	3.7	4.0
Water pressure drop	Kpa	12	12	14	15
Type d'échangeur		Echangeur titane avec tube twisté			
Diamètre entrée-sortie	mm	50			
Nombre de ventilateur		1			
Type de ventilation		Horizontal			
Vitesse de ventilation	RPM	500-850		550-850	
Puissance absorbée par le	W	6-35		22-82	32-110
Niveau de bruit à 10m	dB(A)	≤ 41	≤ 42	≤ 42	≤ 43
Niveau de bruit à 1m	dB(A)	38-51	39-52	40-52	40-54
Réfrigérant (R32)	gr	650	700	1000	1100
CO2 équivalent	T	0.44	0.47	0.68	0.74
* Dimension & Poids					
Poids net	kg	56	68	73	78
Poids brut	kg	68	73	78	83
Dimension	mm	1008*380*577		1050*440*709	
Dimension d'emballage	mm	1095*430*705		1130*470*850	

* Les données ci-dessus sont sujettes à modification sans préavis

Pompe à chaleur pour piscine PRO ELYO INVERBOOST NN

CE Standard, R32

Modes		PROELYXP16i	PROELYXP20i	PROELYXP26i	PROELYXP30i
Codes		71680	71681	71682	71683
* Puissance de chauffage Air 28°C / Eau 28°C / Humidité 80%					
Chauffage	Kw	16-3.8	20-4.7	26-5.9	30-6.8
Consommation d'énergie	Kw	2.39-0.24	2.99-0.29	3.88-0.37	4.55-0.43
C.O.P.		16-6.7	16-6.7	16-6.7	16-6.6
* Puissance de chauffage Air 15°C / Eau 26°C / Humidité 70%					
Chauffage	Kw	11.2-3	14-3.9	18-5.4	22.8-5.6
Consommation d'énergie	Kw	2.24-0.38	2.8-0.49	3.6-0.68	4.56-0.68
C.O.P.		8.2-5	8.2-5	8.2-5	8.2-5
* Puissance de chauffage Air 0°C / Eau 26°C / Humidité 78%					
Chauffage	Kw	7.4-4.1	9.79-4.8	13-6.7	15.89-8.5
Consommation d'énergie	Kw	2.64-0.91	3.5-1.09	4.64-1.52	5.68-1.93
C.O.P.		4.5-2.8	4.4-2.8	4.4-2.8	4.4-2.8
* Puissance de chauffage Air -10°C / Eau 26°C / Humidité 78%					
Chauffage	Kw	5.8-3.6	7.58-4.3	10.4-5.9	12.74-7.4
Consommation d'énergie	Kw	2.64-0.92	3.45-1.1	4.73-1.51	5.79-1.95
C.O.P.		3.9-2.2	3.9-2.2	3.9-2.2	3.8-2.2
* Données générales					
Marque du compresseur		MITSUBISHI INVERTER COMPRESSOR			
Alimentation électrique	V	220-240V/50 or 60Hz/1PH			
Courant Maximal	A	10.5	13.2	17.0	23.0
Disjoncteur	A	16	20	26	35
Volume de bassin	m ³	28-85	58-120	65-132	78-156
Débit d'eau préconisé	m ³ /h	5.0	6.0	8.0	10.0
Water pressure drop	Kpa	15	18	20	25
Type d'échangeur		Twist-titanium tube in PVC			
Diamètre entrée-sortie	mm	50			
Nombre de ventilateur		1		2	
Type de ventilation		Horizontal			
Vitesse de ventilation	RPM	450-650		550-850	
Puissance absorbée par le	W	35-130		32-110	
Niveau de bruit à 10m	dB(A)	≤ 43	≤ 45	≤ 49	≤ 49
Niveau de bruit à 1m	dB(A)	40-54	41-56	42-60	42-60
Réfrigérant (R32)	gr	1500	1900	2000	2600
CO2 équivalent	T	1.01	1.28	1.35	1.76
* Dimension & Poids					
Poids net	kg	98	117	128	130
Poids brut	kg	113	135	146	148
Dimension	mm	1050*450*870		1050*452*1295	
Dimension d'emballage	mm	1140*480*1010		1130*515*1430	



Boîtier à chaleur pour piscine Pro Elyo INVERBOOST NN
 CE Standard 10A

Modes		Pro Elyo Inverboost NN26T	Pro Elyo Inverboost NN 35	Pro Elyo Inverboost NN35T
Codes		68822	68822	68823
Puissance de chauffage Air 28°C / Eau 28°C / Humidité 80%				
Chauffage	Kw	26-5.9	35-8	35-8
Consommation d'énergie	Kw	3.88-0.37	5.22-0.5	5.22-0.5 X
C.O.P.		16-6.7	16-6.7	16-6.7
* Puissance de chauffage Air 15°C / Eau 26°C / Humidité 70%				
Chauffage	Kw	18-5.4	24-5.6	24-5.6

4.1 Liste des accessoires

		
Patin caoutchouc anti-vibration, qté 4	Connecteur d'évacuation, qté 2	Couvercle de protection, qté 1
		
Fil de la commande déportée longueur 10m, qté 1 Modbus fil de raccordement	Connecteurs d'admission et de sortie d'eau, qté 2	Couverture d'hivernage, qté 1

4.2 Le Kit By-Pass (option)

Le kit By-Pass est l'accessoire indispensable pour l'installation de votre pompe à chaleur, c'est aussi un outil pour l'optimisation du fonctionnement de votre pompe à chaleur. Le réglage des vannes permet d'optimiser le débit d'eau et grâce au manomètre de s'assurer du bon fonctionnement du compresseur, voir paragraphe 5.6 contrôle de la pression.

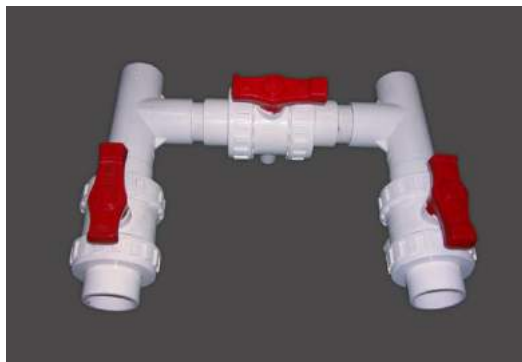

4.3 Installation des accessoires et connexions

	<p>Patin caoutchouc anti-vibration</p> <ol style="list-style-type: none"> 1. Prenez les patins caoutchoucs 2. Déposez-les un par un sous les pieds de la machine.
	<p>Connecteur d'évacuation</p> <ol style="list-style-type: none"> 1. Installez le connecteur d'évacuation sous la machine. 2. Connectez un tuyau d'eau pour évacuer l'eau. <p>Nota : Inclinez légèrement la pompe à chaleur comme sur la photo ci-contre. Ne basculez pas la pompe à chaleur, sinon cela va endommager le compresseur.</p>
	<p>Connecteurs d'admission et de sortie d'eau</p> <ol style="list-style-type: none"> 1. Utilisez du ruban téflon pour installer les connecteurs d'admission et de sortie d'eau dans la pompe à chaleur. 2. Installez les raccords comme sur la photo ci-contre. 3. Vissez sur l'entrée et la sortie d'eau.
	<p>Câble alimentation</p> <ol style="list-style-type: none"> 1. Otez le couvercle de protection du bornier comme sur la photo ci-contre. 2. Borniers L/N/T pour l'alimentation électrique. 3. Borniers 1/2 pour asservir la filtration par la pompe à chaleur (option d'utilisation).
	<p>Câble de la pompe de filtration</p> <ol style="list-style-type: none"> 1. Otez le couvercle de protection du bornier comme sur la photo ci-contre. 2. Connectez les fils dans le bornier électrique en 1 et 2. <p>Note ; Ceci permet d'asservir la filtration par la pompe à chaleur via l'horloge électrique (contact sec).</p>

ATTENTION :

Avant l'installation, merci de prendre connaissance des indications ci-dessous :

1. Tous les systèmes de traitement, doivent être installés **en aval** de la pompe à chaleur.
2. Toujours fixer la pompe à chaleur sur une base plane et horizontale, utiliser les patins en caoutchouc fournis pour éviter les vibrations et les nuisances sonores.
3. Manipuler la pompe à chaleur en position verticale. Si la machine a été basculée, attendez au moins 24 heures avant de démarrer la pompe à chaleur.

5.1 Positionnement de la pompe à chaleur

L'appareil peut être installé presque n'importe où à l'extérieur, à condition que les trois facteurs suivants soient satisfaits :

1. Une bonne ventilation
2. Une alimentation électrique conforme aux normes en vigueur
3. Un système d'eau recyclée

Les distances minimales visualisées dans le schéma page suivante doivent également être respectées. L'installation dans un endroit venteux ne pose aucun problème, sauf si un chauffage au gaz se trouve à proximité (risques dus aux flammes).

ATTENTION : L'unité ne doit pas être installée dans une zone où la ventilation d'air est limitée ou dans des emplacements qui ne peuvent pas fournir de façon continue de l'air. Il faut s'assurer que l'entrée d'air ne puisse jamais être obstruée. Les feuilles et autres débris peuvent se coller sur l'évaporateur, ce qui réduira son efficacité mais aussi, affectera la durée de vie et l'efficacité de la pompe à chaleur.

L'illustration ci-dessous montre la distance minimale requise de chaque côté de la pompe à chaleur.

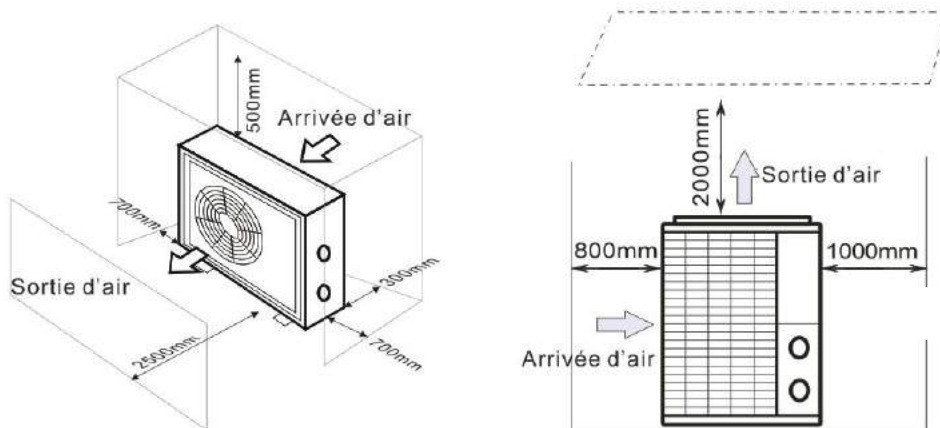

5.2 Installation du clapet anti-retour

▲ NOTE

Si l'équipement de dosage automatique pour le chlore et l'acidité (pH) est utilisé, il est essentiel de protéger la pompe à chaleur contre les produits chimiques à concentration trop élevée qui pourraient corroder l'échangeur thermique. Pour cette raison, ce type d'équipement doit être installé en aval de la pompe à chaleur. Il est recommandé d'installer un clapet anti-retour pour empêcher un écoulement inverse en l'absence de circulation d'eau. Les dommages induits par le non-respect de cette instruction ne sont pas couverts par la garantie.

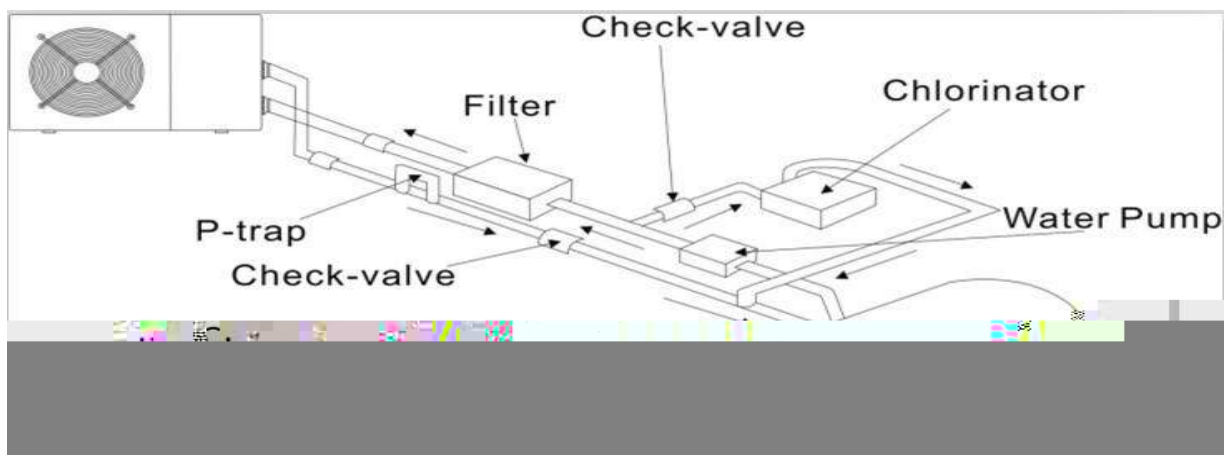

5.3 Installation

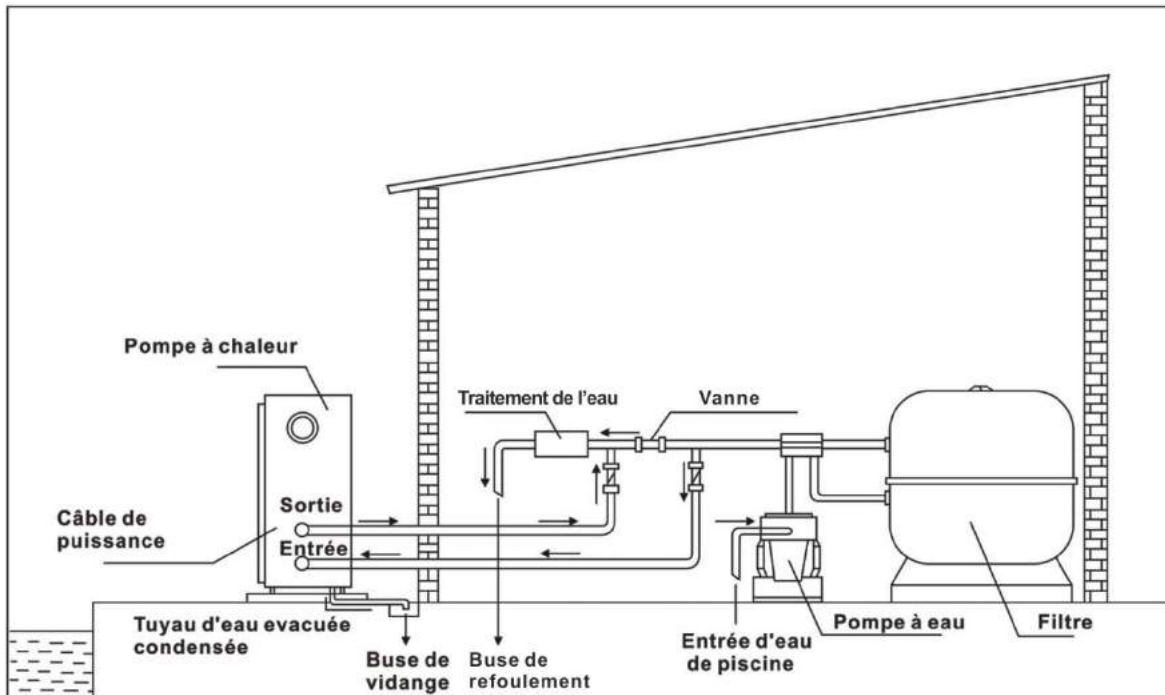

Ce montage est un exemple illustratif.

▲ NOTE

Seule la pompe à chaleur est fournie. Les éléments nécessaires à son installation, y compris le by-pass, doivent être fournis par l'utilisateur ou l'installateur.

ATTENTION :

Au préalable, assurez-vous que la pompe de filtration fonctionne avec un flux de débit d'eau adéquat.

5.4 Mise en service de l'unité

Une fois que toutes les connexions ont été faites voir paragraphe 4 et 5, merci de suivre ces étapes :

(1) Allumez votre pompe de filtration, vérifiez les fuites d'eau et le débit aux buses de refoulement.

(2) Activez l'alimentation électrique de l'appareil, puis appuyez sur la touche ON / OFF  du contrôleur.

(3) Après un fonctionnement de quelques minutes, assurez-vous que la ventilation de l'air est froide.

(4) Lorsque vous désactivez la pompe de filtration, l'unité doit également être désactivée automatiquement, sinon, veuillez contrôler le commutateur de débit.

En fonction de la température initiale de l'eau dans la piscine et de la température de l'air, il est nécessaire de faire fonctionner l'installation pendant plusieurs jours pour chauffer l'eau à la température souhaitée.

Une bonne protection de la piscine (couverture, bâche solaire) peut réduire considérablement la durée requise.

En fonction de la température initiale de l'eau dans la piscine et de la température de l'air, il est nécessaire de faire fonctionner l'installation pendant plusieurs jours pour chauffer l'eau à la température souhaitée.

Une bonne protection de la piscine (couverture, bâche solaire) peut réduire considérablement la durée requise.

NOTE

Commutateur de débit d'eau:

L'unité est équipée d'un détecteur de débit d'eau pour s'assurer que la pompe à chaleur fonctionne avec un débit d'eau suffisant. Il est activé lorsque la pompe de filtration de la piscine fonctionne et il se désactive lorsque la pompe s'arrête.

Temporisation - L'unité est équipée d'une protection intégrée de redémarrage temporisée de 3 minutes. La temporisation est une partie intégrante du circuit de commande et de protection du compresseur.

La fonction de temporisation interdit tout redémarrage automatiquement de l'appareil (pendant environ 3 minutes) après chaque interruption du circuit de commande. Même une brève interruption de courant active la temporisation de 3 minutes et empêche le redémarrage de l'appareil jusqu'à ce que le compte à rebours de 3 minutes soit terminé.

5.5 Condensation

L'air aspiré dans la pompe à chaleur est fortement refroidi par le cycle de fonctionnement de l'unité pour chauffer l'eau de la piscine, ce qui provoque la condensation sur les ailettes de l'évaporateur.

NOTE

Le taux de condensation peut être important avec une humidité relativement élevée, ceci peut être parfois considéré à tort comme une fuite d'eau.

5.6 Contrôle de la pression (R32)

Examinez l'indicateur de pression du gaz de refroidissement qui indique les conditions de travail de l'unité.

Unit Condition	Arrêt compresseur (off)			
	Air (°C)	-5~5	5~15	15~25
Eau (°C)	/	/	/	/
Pression indiqué (Mpa)	0.59~0.85	0.85~1.18	1.18~1.59	1.59~2.1

Unit Condition	Marche compresseur (On)				
	Air (°C)	/	/	/	/
Eau (°C)	10~15	15~20	20~25	25~30	30~35
Pression indiqué (Mpa)	1.1~1.6	1.3~1.8	1.5~2.1	1.7~2.4	1.9~2.7

6.1 Schéma de câblage de la pompe à chaleur de piscine

Ref. 71676/71677/71678/71679/71680

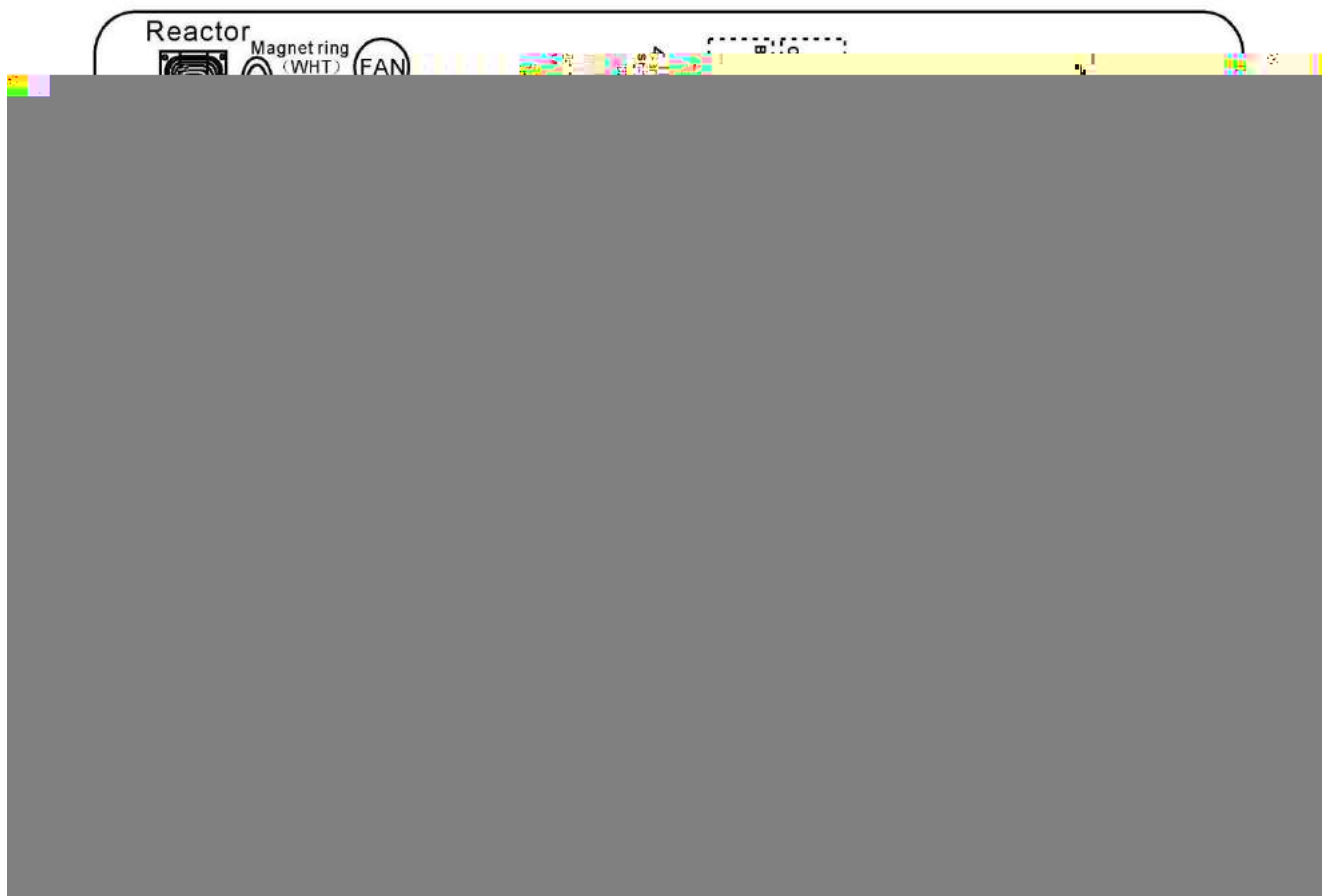

6.2 Schéma de câblage de la pompe à chaleur de piscine

Ref: 71681



6.3 Schéma de câblage de la pompe à chaleur de piscine

Ref: 71682/71683

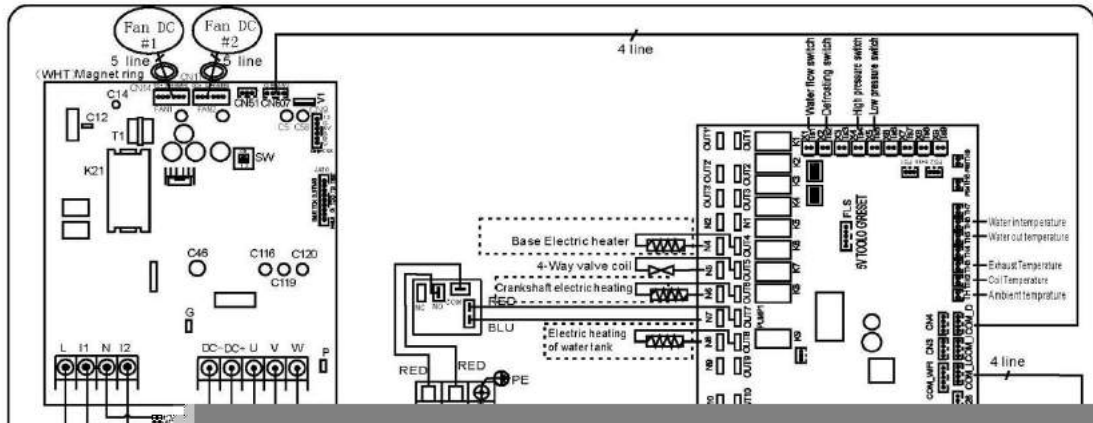

6.4 Schéma de câblage de la pompe à chaleur de piscine Ref. 68822 (R410A)

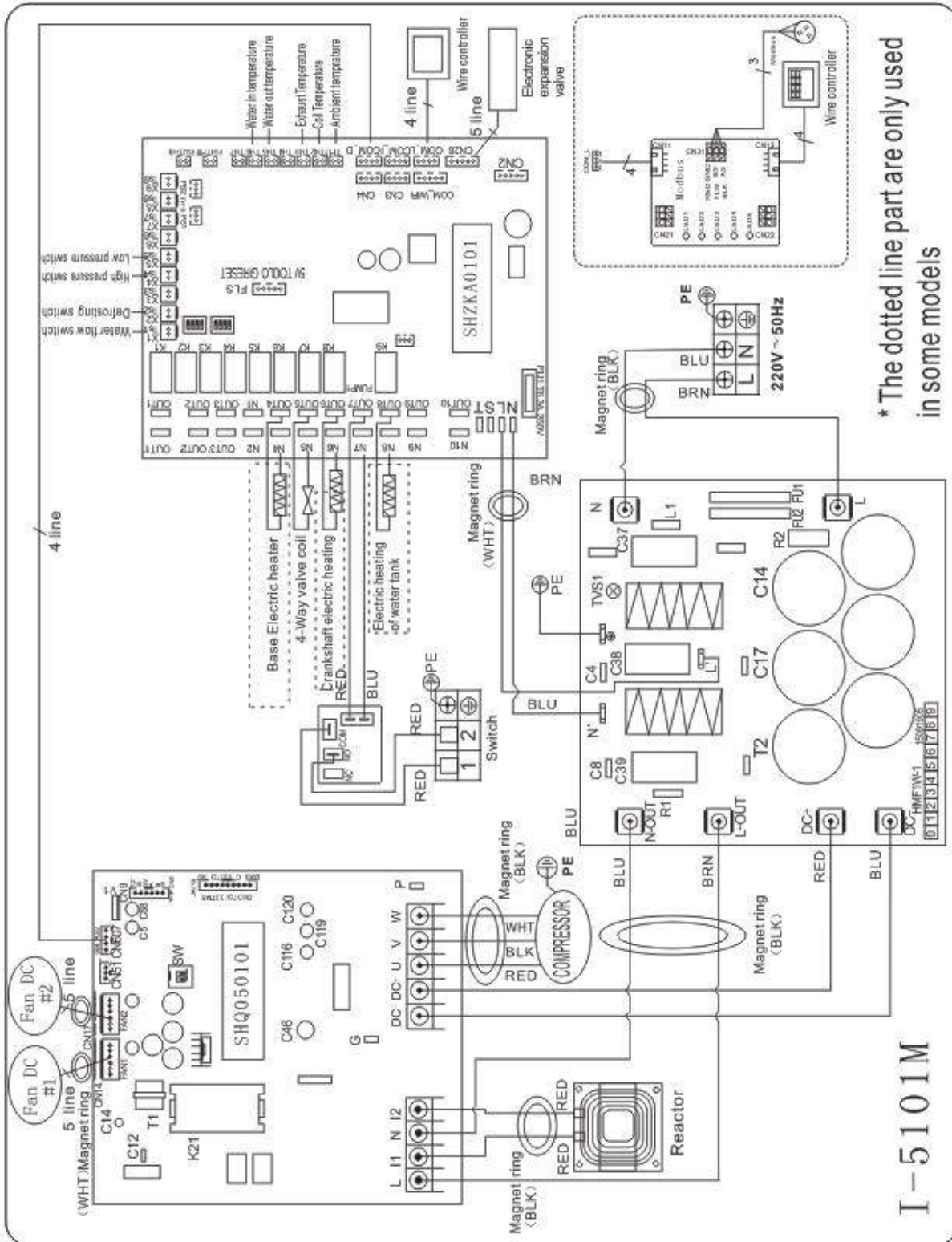

6.5 Schéma de câblage de la pompe à chaleur de piscine

Ref. 68821/68823 (R410A)

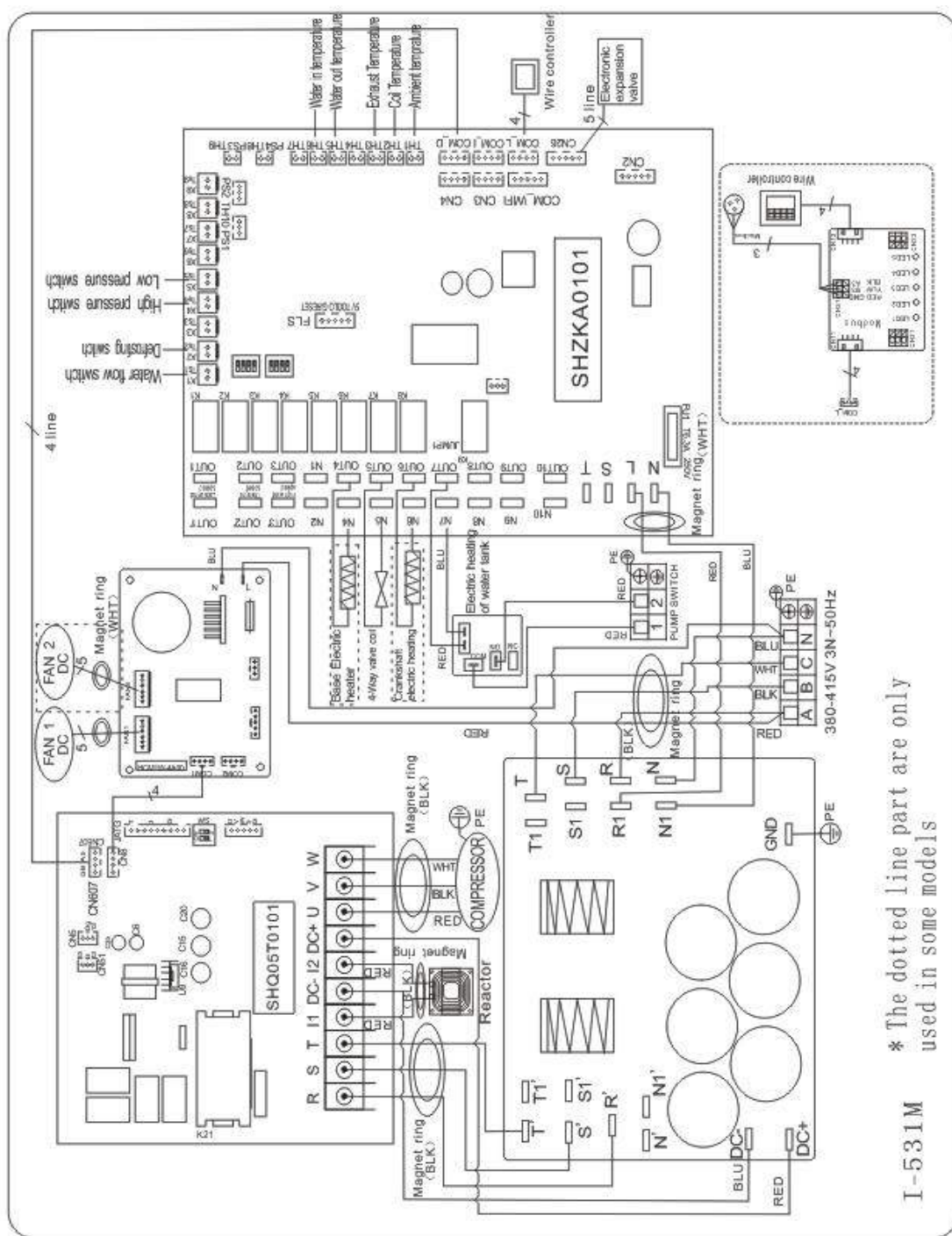

- Les schémas électriques ci-dessus sont pour votre référence, merci de se référer à ceux apposé sur la machine.

6.6 Raccordement électrique

L'alimentation électrique pour la pompe à chaleur doit provenir, préférablement, d'un circuit exclusif avec des composants de protection réglementaires (protection par différentiel 30mA) et un interrupteur magnétothermique.

- L'installation électrique doit être réalisée par un professionnel spécialisé (électricien) conformément aux normes et réglementation en vigueur dans le pays d'installation.
- Le circuit de la pompe à chaleur doit être uni à un circuit de prise de terre de sécurité, au niveau du bloc terminal.
- Les câbles doivent être installés correctement, de façon à prévenir les interférences.
- La pompe est prévue pour son raccordement à une alimentation générale avec prise de terre.
- Section du câble ; Cette section est indicative et doit être vérifiée et adaptée selon les besoins et les conditions d'utilisation.
- La tolérance de variation de tension acceptable est de +/- 10% lors du fonctionnement.

Les raccordements doivent être dimensionnés en fonction de la puissance de l'appareil et de l'état de l'installation

Modes	Protection tête de ligne	Longueur maximum de câble			
		2,5 mm ²	4 mm ²	6 mm ²	10 mm ²
PROELYXP07i	7 A	84 m	135 m	200 m	335 m
PROELYXP09i	9 A	57 m	90 m	130 m	225 m
PROELYXP11i	11A				
PROELYXP14i	14 A	43 m	68 m	100 m	170 m
PROELYXP16i	16 A	34 m	54 m	80 m	135 m
PROELYXP20i	20 A	29 m	45 m	66 m	110 m
PROELYXP26i	26 A	/	25 m	38 m	62 m
PROELYXP30i	35 A	/	/	22 m	36 m
PRO ELYO INVERBOOST NN 26T	9 A	15 m	35 m	49 m	81 m
PRO ELYO INVERBOOST NN 35	34 A	/	/	22 m	36 m
PRO ELYO INVERBOOST NN 35T	13 A	12 m	27 m	39 m	68 m

 Ces valeurs sont données à titre indicatif, seule l'intervention d'un technicien habilité vous permettra de déterminer les valeurs correspondantes à votre installation.

La pompe à chaleur de piscine doit être raccordée à la terre, bien que l'échangeur de chaleur soit électriquement isolé du reste de l'unité. La mise à la terre de l'unité est toujours nécessaire pour vous protéger contre les courts-circuits éventuels de l'unité.

6.7 Installation de la commande déportée

Photo(1)



Photo(2)



Photo(4)



Photo(5)

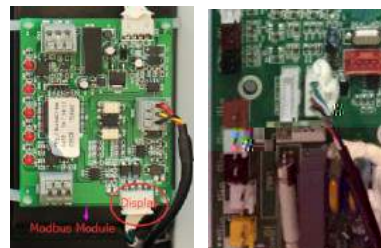

1. Raccordez le fil du signal, avec le contrôleur sur les broches (photos 1 et 2).
2. Passez le fil au travers du bloc de raccordement (photos 3 et 4).
3. Ensuite connecter sur la carte électronique (photos 5).

6.8 Installation de la connexion en Modbus/Fluidra Connect

Photo(6)



Photo(7)



Photo(8)



Photo(9)

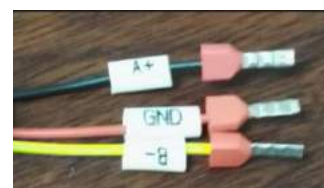

1. Ouvrir le terminal de raccordement (photos 6).
2. Prendre le câble fourni en accessoire (photo 7) et connecter au raccord (photo8).
3. Borne à trois fils : "A +", "B-", "GND" (Photo 9)

ATTENTION :

Disjoncteur : Un moyen d'interruption électrique (disjoncteur, interrupteur à fusibles) doit être en vue et facilement accessible de l'unité. C'est une pratique courante et de sécurité pour les pompes à chaleur résidentielles et commerciales. Il permet la mise hors tension à distance de l'équipement sans surveillance et permet aussi d'isoler l'alimentation à l'unité alors que l'appareil est en réparation.

Raccordement pour déclencher l'horloge de la filtration « mode priorité chauffage »

Minuteur

Bornier

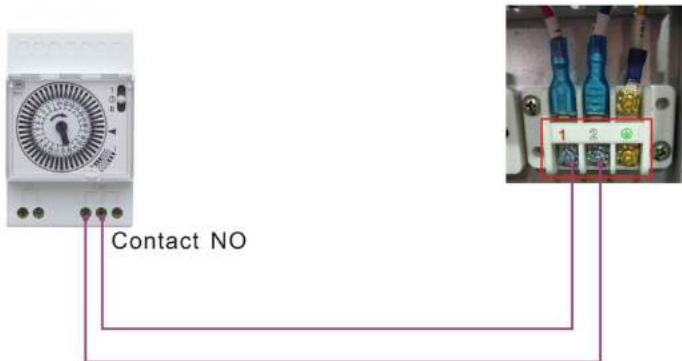

Raccordement direct pour le pilotage de la pompe de filtration, « mode priorité chauffage »

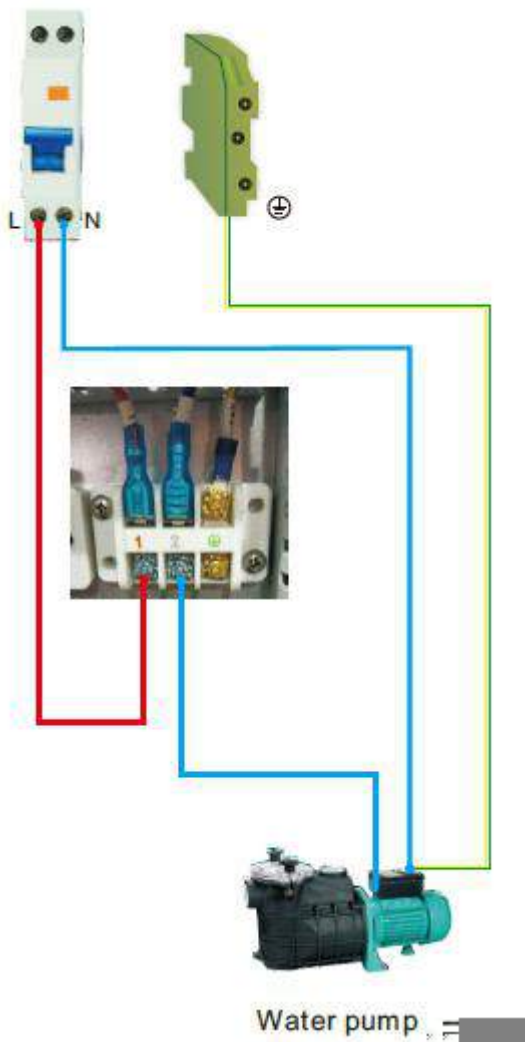

7. Prise en main

7.1. Les fonctions du tableau de commande LED

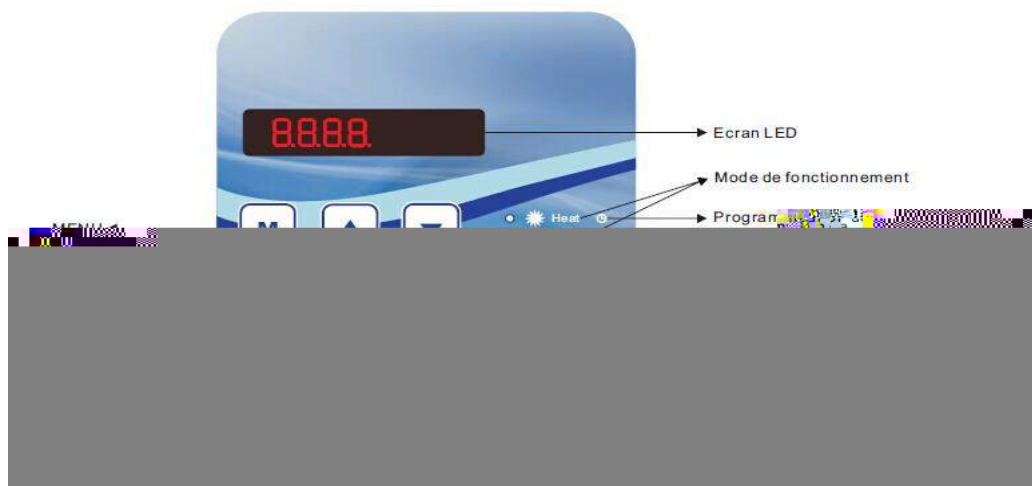

A la mise sous tension de la machine, l'écran affiche pendant 3 secondes le code qui indique le Mode de la pompe à chaleur.

7.2 Démarrer ou arrêter la pompe à chaleur

7.2.1 Touche

Appuyez sur  pour démarrer la pompe à chaleur, l'écran LED affichera la température d'eau demandée pendant 5 secondes, ensuite affichage de la température d'arrivée d'eau.



Appuyez sur  pour arrêter la pompe à chaleur, l'unité s'arrête et l'écran affiche « OFF »

Attention : Après toute mise à jour, appuyez sur  pour sauvegarder la consigne et sortir du Mode réglage.

Appuyez sur  pour arrêter / démarrer la pompe à chaleur.

7.2.2 Touche

La touche est active en association avec les autres touches.



Appuyez sur  pendant 5 secondes, la pompe à chaleur active l'Auto Mode,  et

 s'allume ensemble. Appuyez à nouveau sur  pendant 5 secondes pour sortir de l'Auto Mode,



 s'éteint, la pompe fonctionne en mode chauffage.

7.2.3 Touches et

Déverrouillez la commande :

Appuyez sur  et  pendant 5 secondes pour débloquer la commande.

Réglage de la température de l'eau :

Appuyez sur  et  pour sélectionner la température souhaitée.



Commen e

0 2 F

Appuyez sur  ensuite appuyez sur  afin de vérifier et ajuster les paramètres (de P1 à P7, voir les illustrations en dessous).

Paramétrage des codes produit Paramètre P (MOBUS uniquement)

Appuyez sur  +  pendant 5 secondes, le paramètre P s'affiche et sa valeur correspondante clignote.

Ensuite, appuyez sur  ou  pour ajuster les paramètres du code produit, qui varie de 0 à F.

Appuyez brièvement sur  pour choisir la 2, 3 4me valeur.  pour enregistrer et quittez ou enregistrement automatique et sortie du paramétrage sans action de votre part au bout de 15S.

Après le ré ÔÀ

7.2.4 Retour aux paramètres d'usines

Retour aux paramètres d'usines

Appuyez sur 

7.2.12 Réglage du mode

Il existe 3 modes de fonctionnement, chauffage, mode automatique (basculement du mode chaud vers froid et vice versa en automatique), refroidissement seul. Vous pouvez changer le mode de fonctionnement en

appuyant sur  pendant 5 secondes, peu importe si l'appareil est allumé ou éteint.

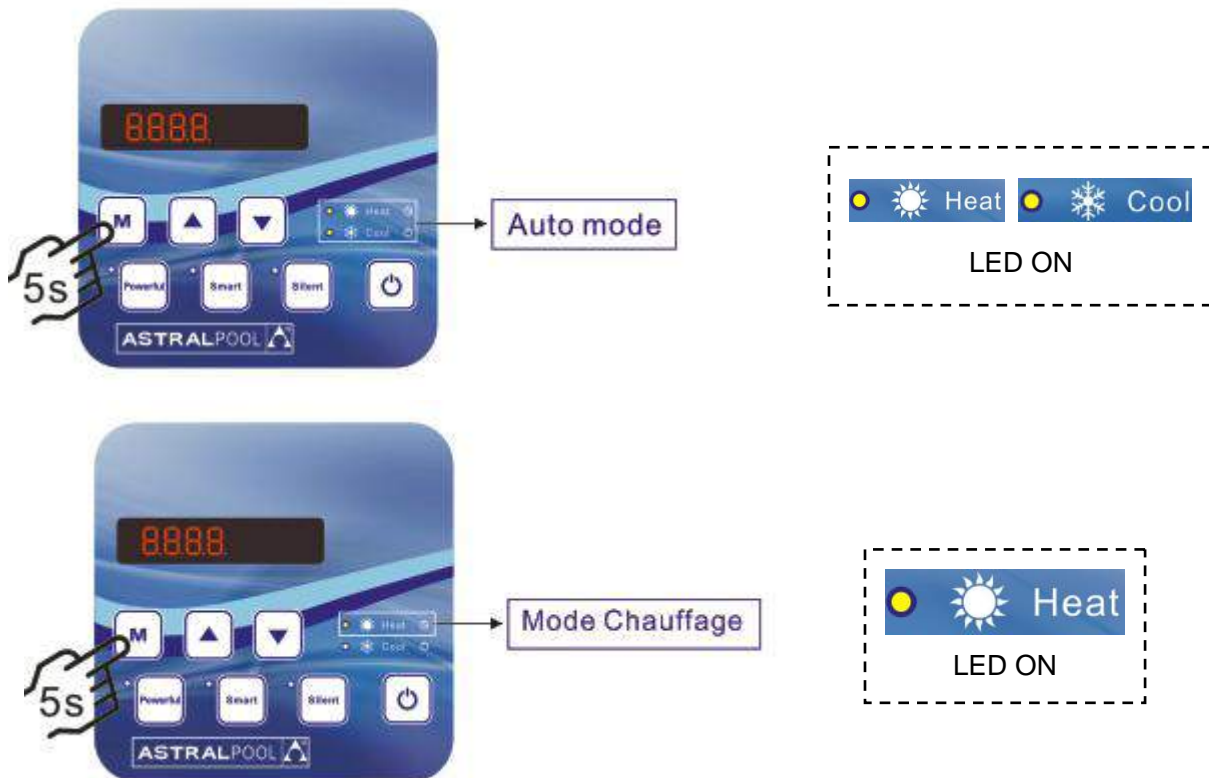

Logique de fonctionnement du mode <Auto mode>

Fonctionnement du mode automatique Auto Mode (basculement chaud/froid)

Option 1

La pompe de filtration est liée au fonctionnement de la pompe à chaleur pour démarrer ou s'arrêter.

La pompe de filtration démarre 60 secondes avant le compresseur, la pompe de filtration démarre 30 secondes et actionne le détecteur de débit d'eau. Lorsque la pompe à chaleur passe en mode veille, la pompe de filtration s'arrête 60 secondes après l'arrêt du compresseur.

La pompe de filtration recommencera à fonctionner pendant 3 minutes, puis s'arrêtera lorsque le temps d'attente sera supérieur à 2 heures.

	État	Exemple	Logique de travail de la pompe de filtration
Mode de chauffage	$T1 > T_{set} - 1$, dure 30 minutes	$T1 > 27^{\circ}\text{C}$, dure 30 minutes	La pompe de filtration entrera en mode veille pendant 2 heures et ne démarrera pas, sauf coupure de l'alimentation et redémarrage. La pompe à chaleur redémarre 3 minutes après que la pompe de filtration a quitté le mode veille pour détecter à nouveau la température de l'eau T1.
Mode de refroidissement	$T1 < T_{set} + 1$, dure 30 minutes	$T1 < 29^{\circ}\text{C}$, dure 30 minutes	La pompe de filtration entrera en mode veille pendant 2 heures et ne démarrera pas, sauf coupure de l'alimentation et redémarrage. La pompe à chaleur redémarre 3 minutes après que la pompe de filtration eau a quitté le mode veille pour détecter à nouveau la température de l'eau T1.

Option 2

Lorsque la pompe à chaleur est en marche (en marche ou en veille), la pompe de filtration sera toujours allumée.

Elle fonctionnera pendant 1 minute après éteint la machine.

REMARQUE :

Tset = régler la température de l'eau

Par exemple: Tset = 28°C régler la température de l'eau dans la pompe à chaleur de votre piscine

Tset-1 = moins de 1°C de la température de consigne

Tset-1 = 28-1 = 27°C

Tset + 1 = plus de 1°C de la température de consigne

Tset+ 1 = 28+1=29°C

7.3 Logique en mode chauffage

Statut de travail		Mode travail	Température de l'eau -T1	Exemple, L'eau en température -T1	Niveau de travail pompe à chaleur
1	Mise en route de la pompe à chaleur	Lorsque vous sélectionnez le "mode Smart "	$T1 < Tset-1$	$T1 < 27^{\circ}\text{C}$	Mode Powerful -fréquence F9
2			$Tset-1 \cong T1 < Tset$	$27^{\circ}\text{C} \cong T1 < 28^{\circ}\text{C}$	Fréquence: F9 -F8-F7,...,-F2
3			$Tset \cong T1 < Tset+1$	$28^{\circ}\text{C} \cong T1 < 29^{\circ}\text{C}$	Mode Silent-fréquence F2
4			$T1 \cong Tset+1$	$T1 \cong 29^{\circ}\text{C}$	La pompe à chaleur sera en veille et cessera de fonctionner jusqu'à ce que l'eau atteigne une température inférieure à 28°C .
5		Lorsque vous sélectionnez le "mode Silent"	$T1 < Tset$	$T1 < 28^{\circ}\text{C}$	Mode Smart -fréquence F5.
6			$Tset \cong T1 < Tset+1$	$28^{\circ}\text{C} \cong T1 < 29^{\circ}\text{C}$	Mode Silent-fréquence F2/F1.
7			$T1 \cong Tset+1$	$T1 \cong 29^{\circ}\text{C}$	La pompe à chaleur sera en veille et cessera de fonctionner jusqu'à ce que l'eau atteigne une température inférieure à 28°C .
8		Lorsque vous sélectionnez le "mode Powerful"	$T1 < Tset+1$	$T1 < 29^{\circ}\text{C}$	Mode Powerful-fréquence F10/F9
9			$T1 \cong Tset+1$	$T1 \cong 29^{\circ}\text{C}$	La pompe à chaleur sera en veille et cessera de fonctionner jusqu'à ce que l'eau atteigne une température inférieure à 28°C .
10	Redémarrage pour chauffer de l'eau après le mode veille	Lorsque la pompe à chaleur fonctionne en "mode Smart"	$T1 \cong Tset$	$T1 \cong 28^{\circ}\text{C}$	Prêt à fonctionner
11			$Tset > T1 \cong Tset-1$	$28^{\circ}\text{C} > T1 \cong 27^{\circ}\text{C}$	Silent-fréquence F2
12			$Tset-1 > T1 \cong Tset-2$	$27^{\circ}\text{C} > T1 \cong 26^{\circ}\text{C}$	Fréquence : F2 -F3-F4,...,-F9
13		$< Tset-2$	$< 26^{\circ}\text{C}$	Powerful-fréquence F9	
14		Lorsque la pompe à chaleur fonctionne en "mode Silent"	$\cong Tset$	$\cong 28^{\circ}\text{C}$	Prêt à fonctionner
15			$Tset > T1 \cong Tset-1$	$28^{\circ}\text{C} > T1 \cong 27^{\circ}\text{C}$	Silent mode-fréquence F2/F1
16			$T1 < Tset-1$	$T1 < 27^{\circ}\text{C}$	Smart -fréquence F5
17	Lorsque la pompe à chaleur fonctionne en "mode Powerful"	$T1 < Tset-1$	$T1 < 27^{\circ}\text{C}$	Powerful -fréquence F10/F9	

7.4 Logique en mode refroidissement

Statut de travail	Mode travail	L'eau en température-T1	Par exemple, L'eau en température-T1	Niveau de travail pompe à chaleur
1		$T1 \cong Tset-1$	$T1 \cong 27^{\circ}C$	Etre prêt
2	Lorsque vous sélectionnez le "mode Smart "	$Tset-1 < T1 \cong Tset$	$27^{\circ}C < T1$	

Mise en route de la pompe à chaleur

8.1 Code d'erreur affichée sur le tableau de commande

Dysfonctionnement	Code d'erreur	Raison	Solutions
Défaillance du capteur de température d'eau arrivée T1-TH6	PP01	Le capteur est en circuit ouvert ou en court-circuit	Vérifiez ou remplacez le capteur
Défaillance du capteur de température d'eau sortie T2-TH5	PP02	Le capteur est en circuit ouvert ou en court-circuit	Vérifiez ou remplacez le capteur
Défaillance du capteur de condenseur de chauffage T3-TH2	PP03	Le capteur est en circuit ouvert ou en court-circuit	Vérifiez ou remplacez le capteur
Défaillance du capteur de gaz de retour	PP04	Le capteur est en circuit ouvert ou en court-circuit	Vérifiez ou remplacez le capteur
Défaillance du capteur de température ambiante T5-TH1	PP05	Le capteur est en circuit ouvert ou en court-circuit	Vérifiez ou remplacez le capteur
Défaillance du capteur de condenseur de refroidissement T6-TH3	PP06	Le capteur est en circuit ouvert ou en court-circuit	Vérifiez ou remplacez le capteur
Protection antigel du premier niveau en hiver	PP07	La température ambiante ou la température d'eau arrivée est trop faible	Protection automatique antigel du premier niveau
Protection de température ambiante trop basse	PP08	La température ambiante ou la température d'eau arrivée est trop faible	1. Vérifier la température 2. Vérifier le by-pass
Température de refroidissement du condenseur trop haute protection T3-TH2	PP10	1. Température ambiante trop haute 2. Problème gaz réfrigérant	1. Vérifier la température 2. Vérifier le gaz
T2-TH5 Température de l'eau trop froide protection en mode refroidissement	PP11	1. Débit d'eau trop faible 2. Température de la sonde T2-TH5 anormale	1. Vérifier le by-pass 2. Vérifier le gaz et la sonde
Protection haute pression TS4	EE01	1. Température ambiante trop haute 2. Température de l'eau trop haute 3. Vérifier la vitesse du ventilateur	1. Vérifier le by-pass 2. Vérifier le ventilateur 3. Vérifier le gaz

Dysfonctionnement	Code d'erreur	Raison	Solutions
Protection basse pression TS5	EE02	<ol style="list-style-type: none"> Réfrigérant ne suffit pas Le débit d'eau n'est pas suffisant Filtre ou vanne électronique bloqué 	<ol style="list-style-type: none"> Vérifiez s'il y a des fuites de gaz, remplissez le réfrigérant Nettoyez l'échangeur d'air Vérifier la charge en gaz
Protection débit d'eau TS1	EE03 ou ON	Débit d'eau insuffisant, erreur sens d'alimentation de l'eau ou détecteur de débit en défaut	Vérifier si le débit est suffisant, si l'alimentation de l'eau est dans le bon sens ou si le détecteur de débit est défaillant
En mode chauffage, défaut surchauffe température (T2-TH5)	EE04	Débit d'eau ne suffit pas, manque d'eau	Vérifier, nettoyer le circuit d'eau, vérifier le détecteur de débit et la sonde (T2-TH5)
Protection température d'échappement (T6-TH3)	EE05	<ol style="list-style-type: none"> Réfrigérant ne suffit pas Le débit d'eau n'est pas suffisant Filtre ou vanne électronique bloqué Défaut sonde T6-TH3 	<ol style="list-style-type: none"> Vérifiez s'il y a des fuites de gaz, remplissez le réfrigérant Vérifier le By-pass Vérifier la charge en gaz Vérifier la sonde T6-TH3
Défaut contrôleur	EE06	<ol style="list-style-type: none"> Le raccordement est défaillant Le contrôleur est défaillant 	<ol style="list-style-type: none"> Vérifiez la connexion Vérifier changer le câble Arrêt / Marche de la machine Vérifier changer le contrôleur
Protection du compresseur	EE07	<ol style="list-style-type: none"> Vérifiez la connexion Vérifier le raccordement Accumulation liquide et gaz Compresseur ou carte électronique défaillant débit d'eau anormal Fluctuation alimentation électrique 	<ol style="list-style-type: none"> Vérifiez le compresseur Vérifier le circuit d'eau Vérifier les tensions d'alimentation Vérifier les phases

Dysfonctionnement	Code d'erreur	Raison	Solutions
Défaillance de communication entre le contrôleur et la carte de puissance	EE08	La connexion n'est pas correcte	Vérifier les connexions, changer le câble ou le contrôleur, redémarrer la pompe ou changer la carte
Défaillance de communication entre le contrôleur et la carte de commande	EE09	La connexion n'est pas correcte	Vérifier les connexions, changer le câble ou le contrôleur, redémarrer la pompe ou changer la carte
Protection haut voltage	EE10	La connexion n'est pas correcte	Vérifier les connexions, changer le câble ou le contrôleur, redémarrer la pompe ou changer la carte
Défaillance carte mère IPM Module	EE11	<ol style="list-style-type: none"> 1. Les données ne sont pas correctes 2. Vérifier le raccordement 3. Accumulation liquide et gaz 4. Compresseur ou la carte est défectueuse 	<ol style="list-style-type: none"> 1. Erreur de programmation, couper l'alimentation électrique et démarrer après 3 minutes 2. Changer la carte 3. Vérifier les phases
L'alimentation électrique est trop faible	EE12	<ol style="list-style-type: none"> 1. La tension d'alimentation n'est pas correcte 2. La carte de puissance est défectueuse 	<ol style="list-style-type: none"> 1. Vérifier la tension d'alimentation 2. Changer la carte
Protection électrique	EE13	<ol style="list-style-type: none"> 1. Les données ne sont pas correctes 2. Le débit est anormal 3. La tension n'est pas stable 4. Défaillance de l'inducteur PFC 	<ol style="list-style-type: none"> 1. Vérifiez le compresseur 2. Vérifier le circuit d'eau 3. Vérifier les tensions d'alimentation 4. Vérifier
Module IPM température de fonctionnement anormale	EE14	<ol style="list-style-type: none"> 1. La tension d'alimentation n'est pas correcte 2. Le moteur du ventilateur est défectueux ou les hélices sont cassées 	<ol style="list-style-type: none"> 1. Vérifiez la carte électronique 2. Vérifier la vitesse du ventilateur 3. Vérifier les hélices

Dysfonctionnement	Code d'erreur	Raison	Solutions
Protection haute temp. module IPM	EE15	<ol style="list-style-type: none"> 1. La tension d'alimentation n'est pas correcte 2. Le moteur du ventilateur est défectueux ou les hélices sont cassées 	<ol style="list-style-type: none"> 1. Vérifiez la carte électronique 2. Vérifier la vitesse du ventilateur 3. Vérifier les hélices
Protection module PFC	EE16	<ol style="list-style-type: none"> 1. Les données ne sont pas correctes 2. Le moteur du ventilateur est défectueux ou les hélices sont cassées 3. La tension n'est pas stable 	<ol style="list-style-type: none"> 1. Vérifiez la carte électronique 2. Vérifier la vitesse du ventilateur 3. Vérifier les hélices 4. Vérifier la tension
Défaut ventilateur DC	EE17	<ol style="list-style-type: none"> 1. Le moteur du ventilateur est défectueux 2. La carte électronique est défectueuse 3. Les hélices sont défectueuses 	<ol style="list-style-type: none"> 1. Vérifiez le moteur du ventilateur 2. Changer la carte électronique 3. Vérifier les hélices
Module PFC température de fonctionnement anormale	EE18	La carte électronique est défectueuse	<ol style="list-style-type: none"> 1. Changer la carte électronique 2. Vérifier la vitesse du ventilateur 3. Vérifier les hélices
Protection haute temp. module PFC	EE19	<ol style="list-style-type: none"> 1. La tension d'alimentation n'est pas correcte 2. Le moteur du ventilateur est défectueux ou les hélices sont cassées 	<ol style="list-style-type: none"> 1. Vérifiez la carte électronique 2. Vérifier la vitesse du ventilateur 3. Vérifier les hélices
Défaut puissance d'alimentation	EE20	La puissance d'alimentation varie de façon trop importante	Vérifier la tension d'alimentation

Dysfonctionnement	Code d'erreur	Raison	Solutions
Défaut programme	EE21	<ol style="list-style-type: none"> 1. Le compresseur perd des pas, vitesse irrégulière 2. Défaut programme 3. Impureté dans le compresseur 	<ol style="list-style-type: none"> 1. Vérifiez la carte électronique 2. Recharger le programme
Protection haute tension	EE22	<ol style="list-style-type: none"> 1. La tension d'alimentation n'est pas correcte 2. La carte d'alimentation est défectueuse 	<ol style="list-style-type: none"> 1. Vérifiez la carte électronique 2. Changer la carte électronique
Défaut démarrage du compresseur	EE23	<ol style="list-style-type: none"> 1. La carte d'alimentation est défectueuse 2. Vérifier le raccordement 3. Accumulation liquide et gaz 4. La tension n'est pas stable 	<ol style="list-style-type: none"> 1. Vérifiez la carte électronique 2. Vérifier les raccordements ou changer le compresseur
Température ambiante ou carte électronique	EE24	La température ambiante ou la température d'eau arrivée est trop faible	Vérifier et changer la carte électronique
Défaut alimentation du compresseur	EE25	Le compresseur marche sur 1 ou 2 phases	Vérifier le câblage
Défaut inversion vanne 4 voies	EE26	<ol style="list-style-type: none"> 1. blocage inversion vanne 4 voies 2. Le relai est défaillant 	<ol style="list-style-type: none"> 1. Basculer du mode chaud / froid pour vérifier l'inversion de la vanne 2. Changer la vanne 4 voies 3. Changer le relai de pilotage
Défaut données mémoire EEPROM	EE27	<ol style="list-style-type: none"> 1. Perte des données dans la mémoire 2. Défaut carte électronique 	<ol style="list-style-type: none"> 1. Recharger les données dans la mémoire 2. Changer la carte électronique
Défaut de communication avec le contrôleur	EE28	Défaut sur la carte électronique	<ol style="list-style-type: none"> 1. Arrêt / marche pour redémarrer 2. Vérifier et changer la carte électronique

Remarques:

1. En mode chauffage, si la température de sortie d'eau est supérieure à la température réglée de 7°C, le contrôleur affich 

8.2 Dysfonctionnement sans code d'erreurs affichées sur l'écran

Dysfonctionnements	Observations	Raisons	Solutions
La Pompe à chaleur ne fonctionne pas	Aucun affichage sur le contrôleur à LED	Pas d'alimentation	Vérifiez le disjoncteur du câble et du circuit soit connecté
	Contrôleur à LED affiche l'heure	Pompe à chaleur en état de veille	Démarrez la pompe à chaleur.
	Contrôleur à LED affiche la température réelle de l'eau.	1. Température de l'eau atteint presque la valeur fixée, pompe à chaleur est en état à température constante. 2. Pompe à chaleur commence juste à fonctionner 3. En état de dégivrage	1. Vérifiez le réglage de température de l'eau. 2. Démarrez la pompe à chaleur après quelques minutes. 3. Contrôleur à LED doit afficher "Dégivrage"
La Température de l'eau est refroidie lorsque la pompe à chaleur fonctionne sous le mode de chauffage	Contrôleur à LED affiche la température réelle de l'eau et aucun code d'erreur ne s'affiche	1. Choix du mauvais mode. 2. Les chiffres montrent des défaillances. 3. Défaillance du contrôleur	1. Réglez le mode à la bonne fonction 2. Remplacez le contrôleur à LED en panne, puis vérifiez l'état après avoir changé le mode de fonctionnement, vérifiez la température d'eau d'arrivée et de sortie 3. Remplacez ou réparez l'unité
Fonctionnement court	Contrôleur à LED affiche la température réelle de l'eau, aucun code d'erreur ne s'affiche	1. Ventilateur ne fonctionne pas 2. La ventilation d'air n'est pas suffisante 3. Réfrigérant ne suffit pas.	1. Vérifiez les connexions des câbles entre le moteur et le ventilateur, le cas échéant, il doit être remplacé. 2. Vérifiez l'emplacement de l'unité de pompe à chaleur, et éliminez tous les obstacles pour faire bonne ventilation. 3. Remplacez ou réparez l'unité
Tâches d'eau	Les tâches d'eau sur la pompe à chaleur	1. Protection. 2. Infiltration d'eau.	1. Aucune action (condensat) 2. Vérifiez l'échangeur de chaleur en titane avec soin, s'il y a une fuite
Trop de glace sur l'évaporateur	Trop de glace sur l'évaporateur.		1. Vérifiez l'emplacement de l'unité de pompe à chaleur, et éliminez tous les obstacles 2. Contacter le service technique

9. 1 Schéma éclaté
Mode: 71676

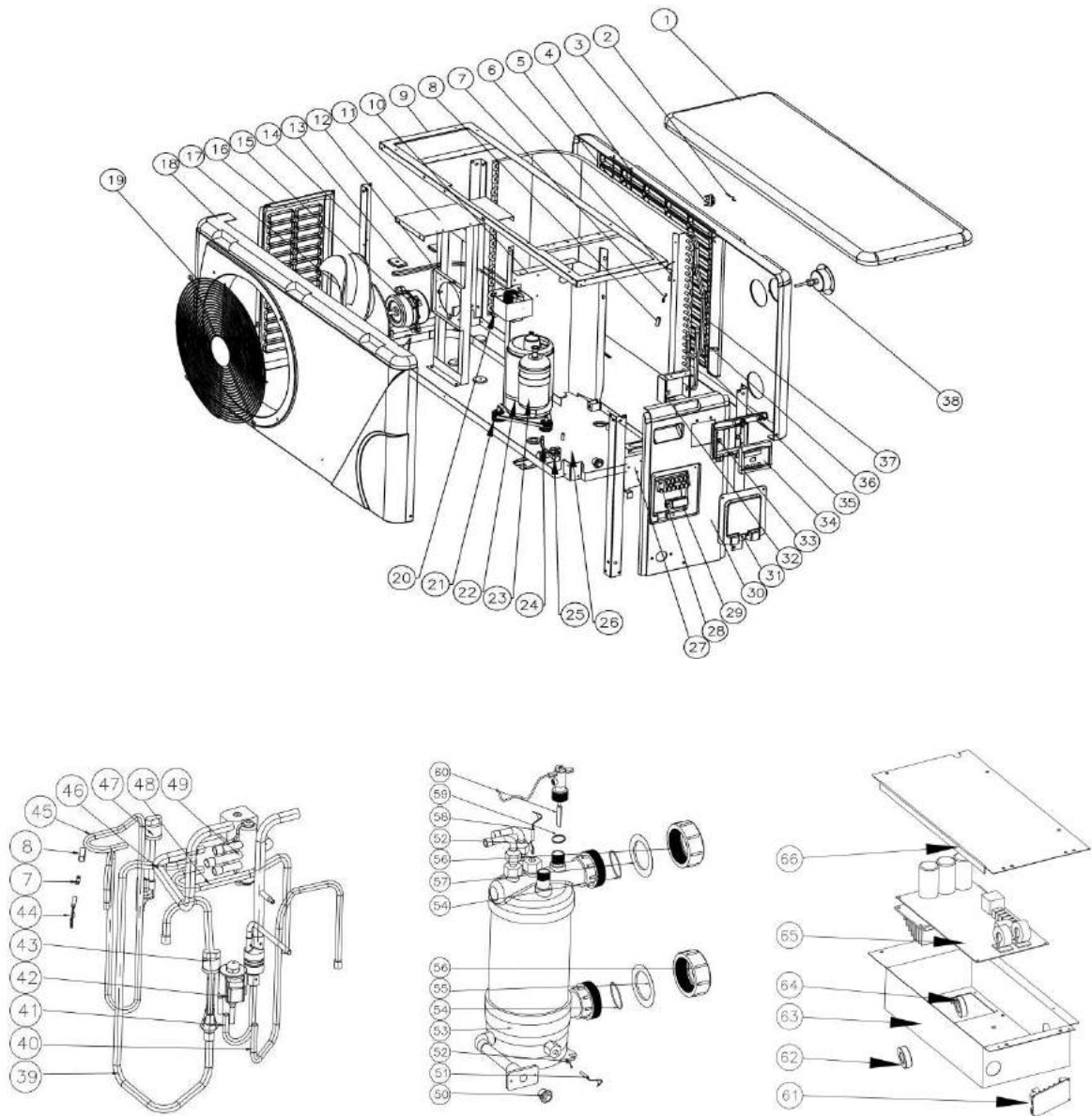

9.2 Liste des pièces détachées

Modèle : 71676

NO	ERP	Désignation	NO	ERP	Désignation
1	1330900291	Panneau supérieur	34	117020180	Boitier de connexion
2	117110020	Sonde de température ambiante T5-TH1	35	103000227	Couvercle de protection
3	133020010	Clip de fixation sonde	36	136020018	Contrôleur
4	1330900271	Panneau arrière	37	103000227	Distribution gaz
5	103000227	Evaporateur	38	106000011	Pieds amortisseurs du compresseur
6	117110004	Sonde de température dégivrage T3-TH2	39	113020320	Tuyauterie de distribution
7	113190001	Fourreau sonde de température	40	113080074	Manomètre
8	113190001	Clip	41	113070042	Tube retour gaz
9	108110038	Cadre supérieur	42	119000017	Distribution gaz
10	108050073	Panneau d'isolation	43	116000071	Tube échangeur vers EEV
11	108110043	Support ventilateur	44	117110021	Détendeur électronique
12	142000058	Courroie chauffante de l'évaporateur	45	113010229	Sonde passe pression
13	108480015	Fixateur de ceinture	46	113030081	Sonde température d'échappement T6-TH3
14	108110004	Pilier arrière gauche	47	116000066	Tube échappement gaz
15	112000031	Moteur ventilateur	48	113060123	Tube vanne 4 voies vers échangeur
16	1330900261	Panneau côté gauche	49	121000006	Sonde haute pression
17	132000015	Pâle ventilateur	50	150000110	Tube
18	1330900251	Panneau avant	51	117110012	Vanne 4 voies
19	108010014	Grille de protection ventilateur	52	108010025	Bouchon de vidange
20	117230003	Réacteur	53	102040705	Sonde de température d'arrivée d'eau T1-TH6
21	101000187	Pieds amortisseurs du compresseur	54	133020026	Clip de fixation sonde de température
22	142000072	Ceinture protection compresseur	55	133020011	Echangeur en titane
23	101000187	Compresseur	56	113900082	Joint raccord d'eau
24	113100008	Outil de couplage	57	133020011	Joint bleu
25	120000091	Vanne gaz	58	117110011	Raccord à visser
26	180140064	Base	59	116000001	Joint rouge
27	108010065	Platine boitier de raccordement	60	112100021-1	Sonde de température de sortie d'eau T2-TH5
28	115000004	Bornier de connexion	61	117010095	Joint détecteur de débit
29	113100009	Clip de fixation sonde	62	117240002	Détecteur de débit
30	1330900281	Panneau côté droit	63	108110057	Module Modbus
31	1332500051	Blocs de jonction en plastique	64	117240003	Anneau magnétique
32	108010018	Boitier de connexion	65	117100046	Coffret électrique
33	113712007	Couvercle de protection	66	108050017	Anneau magnétique

9.3 Modèle : 71677/71678/71679

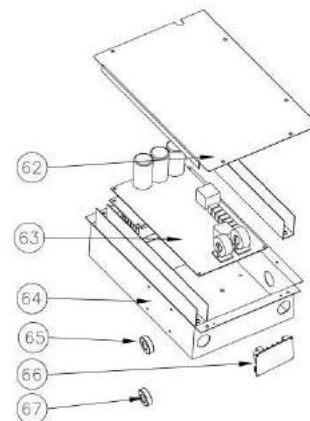
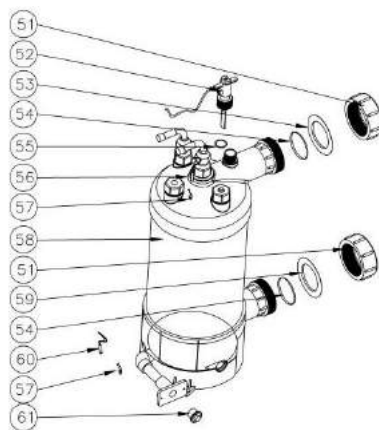
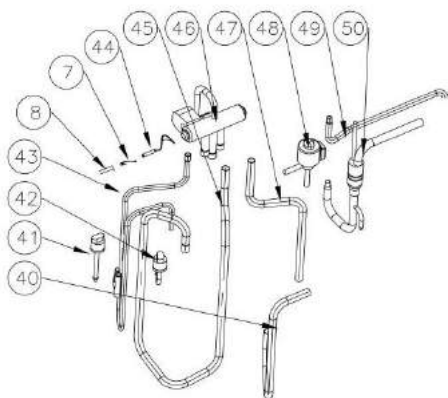
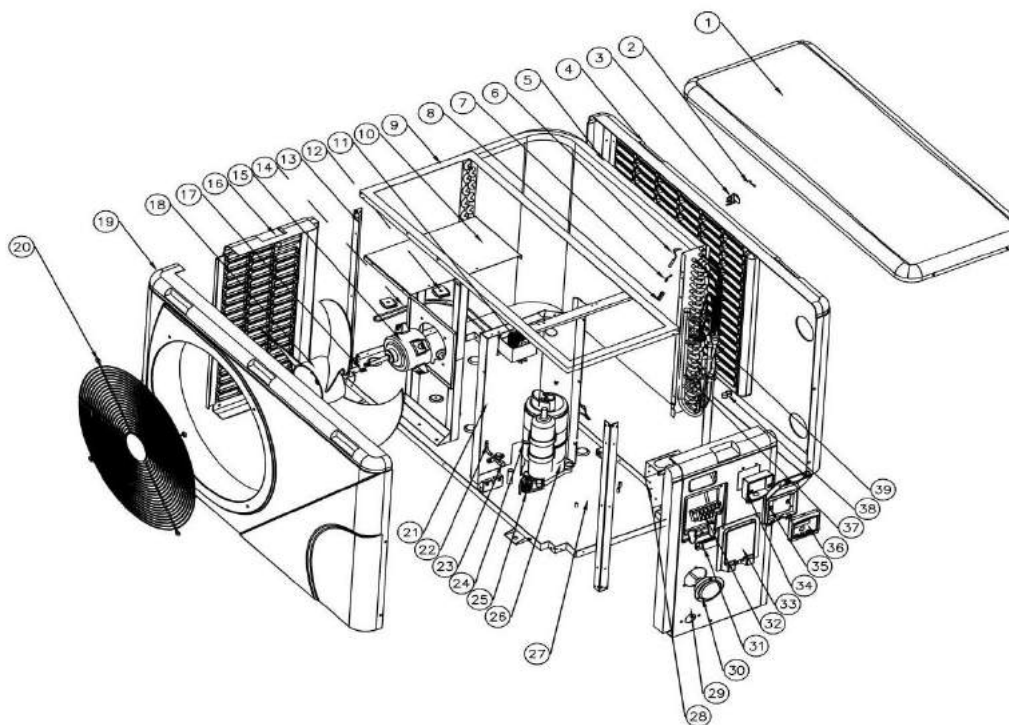

9.4 Liste des pièces détachées :

Modèle : 71677

NO	ERP	Désignation	NO	ERP	Désignation
1	1330900291	Panneau supérieur	35	113712007	Couvercle de protection
2	117110020	Sonde de température ambiante T5-TH1	36	117020180	Contrôleur
3	133020010	Clip de fixation sonde de température	37	103000221	Tube gaz
4	1330900271	Panneau arrière	38	136020005	Bloc de caoutchouc
5	103000221	Evaporateur	39	103000221	Distribution gaz
6	117110004	Sonde de température dégivrage T3-TH2	40	113030086	Tube vanne 4 voies vers échangeur
7	113100009	Clip de fixation sonde de température	41	116000066	Sonde haute pression
8	113100009	Fourreau sonde de température	42	116000071	Sonde passe pression
9	108110038	Cadre supérieur	43	113010210	Tube échappement
10	108110043	Support ventilateur	44	117110021	Sonde température d'échappement T6-TH3
11	117230003	Réacteur	45	113020322	Tube retour gaz
12	108480015	Pince de ceinture	46	121000006	Vanne 4 voies
13	108110004	Pilier arrière gauche	47	113060084	Tube vanne 4 voies
14	142000079	Courroie chauffante de l'évaporateur	48	119000017	Détendeur électronique
15	112000031	Moteur ventilateur	49	113080054	EEV à la tuyauterie de distribution
16	1330900261	Panneau côté gauche	50	113070044	Echangeur à EEV
17	108010024	Cache de tube de moteur à courant continu	51	113900082	Raccord à visser
18	132000015	Pâle ventilateur	52	112100021-1	Détecteur de débit
19	1330900251	Panneau avant	53	133020012	Joint rouge
20	108010014	Grille de protection ventilateur	54	133020026	Joint raccord d'eau
21	108050073	Panneau d'isolation	55	136020083	Joint détecteur de débit
22	113100008	Tuyau de cuivre	56	117110011	Sonde de température de sortie d'eau T2-TH5
23	120000091	Vanne gaz	57	108010025	Clip de fixation sonde de température
24	142000074	Ceinture protection compresseur	58	102040748	Echangeur en titane
25	101000188	Pieds amortisseurs du compresseur	59	133020011	Joint bleu
26	101000188	Compresseur	60	117110012	Sonde de température d'arrivée d'eau T1-TH6
27	108110066	Base	61	150000110	Bouchon de vidange
28	108010065	Platine boîtier de raccordement	62	108050017	Couvercle de boîte électrique
29	133090028	Panneau côté droit	63	117100046	Carte électronique
30	106000011	Manomètre	64	108110031	Coffret électrique
31	136010004	Clip de fixation sonde de température	65	117240002	Anneau magnétique
32	115000004	Bornier de connexion	66	117010095	Module Modbus
33	1332500051	Blocs de jonction en plastique	67	117240003	Anneau magnétique
34	133030011	Boîtier de connexion			

9.5 Liste des pièces détachées :

Modèle : 71678

NO	ERP	Désignation	NO	ERP	Désignation
1	1330900291	Panneau supérieur	35	113712007	Couvercle de protection
2	117110020	Sonde de température ambiante T5-TH1	36	117020180	Contrôleur
3	133020010	Clip de fixation sonde	37	103000182	Tube gaz
4	1330900271	Panneau arrière	38	136020005	Caoutchouc forme B
5	103000182	Évaporateur	39	103000182	Distribution gaz
6	117110004	Sonde de température dégivrage T3-TH2	40	113030086	Tube vanne 4 voies vers échangeur
7	113100009	Fourreau sonde de température	41	116000066	Sonde haute pression
8	113100009	Clip de fixation sonde	42	116000071	Sonde passe pression
9	108110038	Cadre supérieur	43	113010210	Tube échappement
10	108110043	Support ventilateur	44	117110021	Sonde température d'échappement T6-TH3
11	117230003	Réacteur	45	113020322	Tube retour gaz
12	108480015	Fixateur de ceinture	46	121000006	Vanne 4 voies
13	108110004	Pilier arrière gauche	47	113060084	Tube vanne 4 voies
14	142000079	Courroie chauffante de l'évaporateur	48	119000017	EEV
15	112000031	Moteur ventilateur	49	113080054	EEV à Distribution gaz
16	1330900261	Panneau côté gauche	50	113070044	Tube échangeur vers EEV
17	108010024	Commande détendeur électronique	51	113900082	Raccord à visser
18	132000015	Pâle ventilateur	52	112100021-1	Détecteur de débit
19	133090025	Panneau avant	53	133020011	Joint rouge
20	108010014	Grille de protection ventilateur	54	133020026	Joint raccord d'eau
21	108050073	Panneau d'isolation	55	116000001	Joint détecteur de débit
22	113100008	Outil de couplage	56	117110011	Sonde de température de sortie d'eau T2-TH5
23	120000091	Vanne gaz	57	117110012	Clip de fixation sonde de température
24	142000074	Ceinture protection compresseur	58	102040708	Echangeur en titane
25	101000188	Pieds amortisseurs du compresseur	59	133020011	Joint bleu
26	101000188	Compresseur	60	117110012	Sonde de température d'arrivée d'eau T1-TH6
27	108110066	Base	61	150000110	Bouchon de vidange
28	108010065	Platine boîtier de raccordement	62	108050017	Couvercle de protection
29	1330900281	Panneau côté droit	63	117100047	PCB
30	106000011	Manomètre	64	108110057	Coffret électrique
31	136010004	Clip de fixation sonde	65	117240002	Anneau magnétique
32	115000004	Bornier de connexion	66	117010095	Modbus module
33	1332500051	Couvercle de protection	67	117240003	Anneau magnétique
34	133030011	Boîtier de connexion			

9.6 Liste des pièces détachées :

Modèle : 71679

NO	ERP	Désignation	NO	ERP	Désignation
1	1330900291	Panneau supérieur	35	113712007	Couvercle de protection
2	117110020	Sonde de température ambiante T5-TH1	36	117020180	Contrôleur
3	133020010	Clip de fixation sonde température ambiante	37	103000220	Tube gaz
4	1330900271	Panneau arrière	38	136020005	Caoutchouc forme B
5	103000220	Évaporateur	39	103000220	Distribution gaz
6	117110004	Sonde de température dégivrage T3-TH2	40	113030081	Tube vanne 4 voies vers échangeur
7	113100009	Fourreau sonde de température	41	116000066	Sonde haute pression
8	113100009	Clip de fixation sonde de température	42	116000071	Sonde passe pression
9	108110038	Cadre supérieur	43	113010159	Tube échappement
10	108110043	Support ventilateur	44	117110021	Sonde température d'échappement T6-TH3
11	117230003	Réacteur	45	113020321	Tube retour gaz
12	108480015	Fixateur de ceinture	46	121000006	Vanne 4 voies
13	108110004	Pilier arrière gauche	47	113060084	Tube vanne 4 voies
14	142000079	Courroie chauffante de l'évaporateur	48	119000017	EEV
15	112000031	Moteur ventilateur	49	113080054	EEV à Distribution gaz
16	1330900261	Panneau côté gauche	50	113070041	Tube échangeur vers EEV
17	108010024	Commande détenteur électronique	51	113900082	Raccord à visser
18	132000015	Pâle ventilateur	52	112100021-1	Détecteur de débit
19	1330900251	Panneau avant	53	133020012	Joint rouge
20	108010014	Grille de protection ventilateur	54	133020026	Joint raccord d'eau
21	108050073	Panneau d'isolation	55	116000001	Joint détecteur de débit
22	113100008	Outil de couplage	56	117110011	Sonde de température de sortie d'eau T2-TH5
23	120000091	Globe Valve	57	108010025	Clip de fixation sonde de température
24	142000074	Ceinture protection compresseur	58	102040710	Echangeur en titane
25	101000181	Pieds amortisseurs du compresseur	59	133020011	Joint bleu
26	101000181	Compresseur	60	117110012	Sonde de température d'arrivée d'eau T1-TH6
27	108110044	Base	61	150000110	Bouchon de vidange
28	108010065	Platine boîtier de raccordement	62	108050017	Couvercle de protection
29	133090028	Panneau côté droit	63	117100047	PCB
30	106000011	Manomètre	64	108110045	Coffret électrique
31	136010004	Clip de fixation sonde de température	65	117240002	Anneau magnétique
32	115000004	Bornier de connexion	66	117010095	Modbus module
33	1332500051	Couvercle de protection	67	117240003	Anneau magnétique
34	133030011	Boîtier de connexion			

9.7 Modèle : 71680/71681

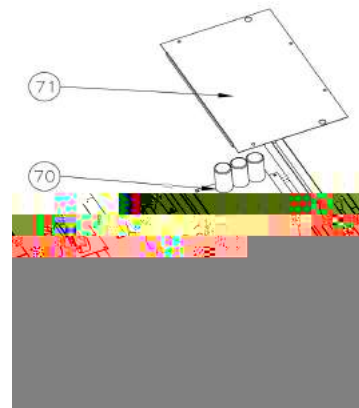
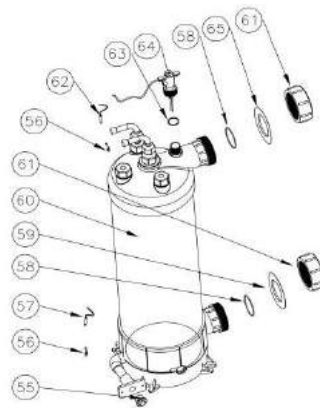
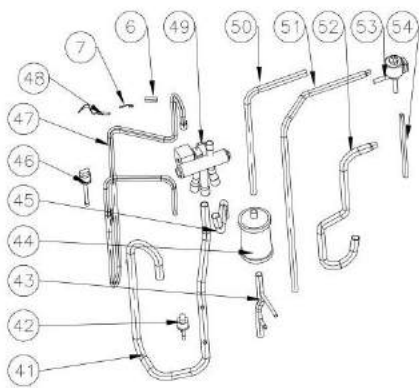
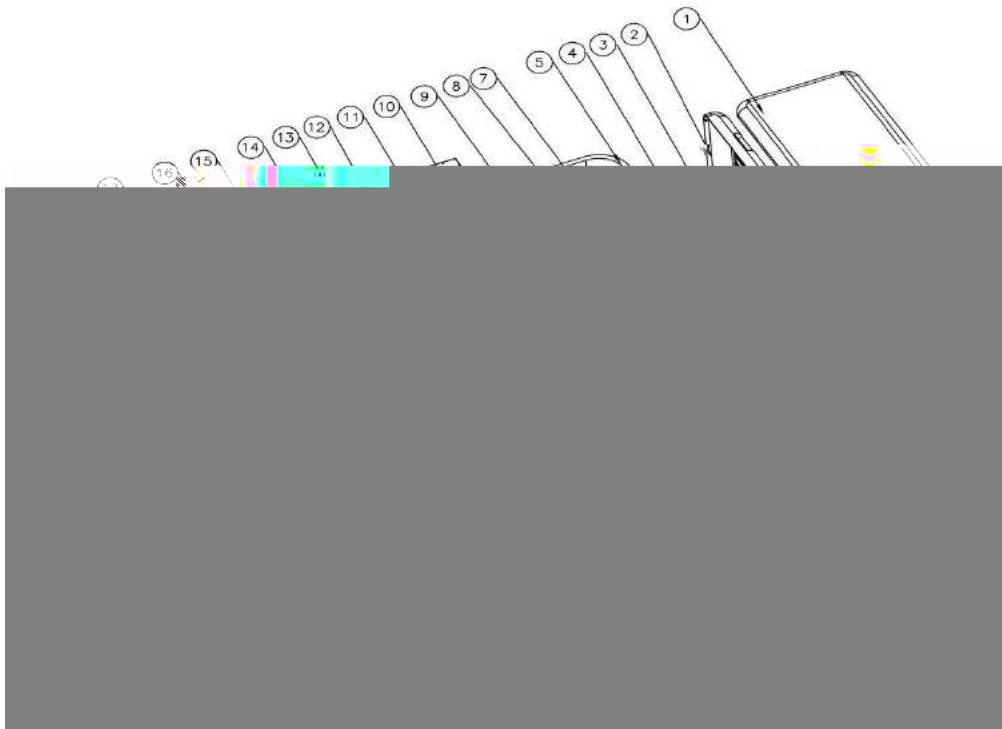

9.8 Liste des pièces détachées :

Modèle : 71680

NO	ERP	Désignation	NO	ERP	Désignation
1	1332600011	Panneau supérieur	37	1332600041	Panneau côté droit
2	1332600021	Panneau arrière	38	103000230	Distribution gaz
3	117110020	Sonde de température ambiante T5-TH1	39	136020005	Bloc de caoutchouc
4	133020010	Clip de fixation sonde température	40	103000230	Tube gaz
5	103000230	Evaporateur	41	113020338	Tube retour gaz
6	113100009	Fourreau sonde de température	42	116000073	Sonde passe pression
7	113100009	Clip de fixation sonde de température	43	113130021	Tube filtre au réservoir de stockage
8	117110004	Sonde de température dégivrage T3-TH2	44	120000066	Filtre
9	117230002	Réacteur	45	113060122	Tube vanne 4 voies
10	108560003	Pilier arrière gauche	46	116000068	Sonde haute pression
11	108560002	Cadre supérieur	47	113010244	Tube échappement
12	108480015	Pince de ceinture	48	117110021	Sonde température d'échappement T6-TH3
13	142000079	Courroie chauffante de l'évaporateur	49	121000006	Vanne 4 voies
14	108560011	Support ventilateur	50	113170032	Tube échangeur vers filtre
15	112000031	Moteur ventilateur	51	113120019	Tube du réservoir de stockage à EEV
16	132000023	Pâle ventilateur	52	113030108	Tube vanne 4 voies vers échangeur
17	1332600051	Panneau côté gauche	53	119000021	Détendeur électronique
18	1332600031	Panneau avant	54	113080056	EEV à la tuyauterie de distribution
19	108170017	Grille de protection ventilateur	55	150000110	Bouchon de vidange
20	108560036	Base	56	108010025	Clip de fixation sonde de température
21	101000185	Compresseur	57	117110012	Sonde de température d'arrivée d'eau T1-TH6
22	101000185	Pieds amortisseurs du compresseur	58	133020026	Joint raccord d'eau
23	142000077	Ceinture protection compresseur	59	133020011	Joint bleu
24	105000004	Chemin de câbles	60	102040703	Echangeur en titane
25	108560010	Panneau d'isolation	61	113900082	Raccord à visser
26	120000091	Vanne gaz	62	117110011	Sonde de température de sortie d'eau T2-TH5
27	108560034	Valve gaz panneau	63	136020083	Joint détecteur de débit
28	113100008	Tuyau de cuivre	64	112100021-1	Détecteur de débit
29	108010065	Platine boîtier de raccordement	65	133020012	Joint rouge
30	133030011	Boîtier de connexion	66	117010095	Module Modbus
31	136010004	Clip de fixation sonde de température	67	117240002	Anneau magnétique
32	106000011	Manomètre	68	117240003	Anneau magnétique
33	1332500051	Blocs de jonction en plastique	69	108560012	Coffret électrique
34	115000004	Bornier de connexion	70	117100048	Carte électronique
35	117020180	Contrôleur	71	108540006	Couvercle de boîte électrique
36	113712007	Couvercle de protection			

9.9 Liste des pièces détachées :

Modèle : 71681

NO	ERP	Désignation	NO	ERP	Désignation
1	1332600011	Panneau supérieur	37	1332600041	Panneau côté droit
2	1332600021	Panneau arrière	38	103000230	Distribution gaz
3	117110020	Sonde de température ambiante T5-TH1	39	136020005	Bloc de caoutchouc
4	133020010	Clip de fixation sonde température	40	103000230	Tube gaz
5	103000230	Evaporateur	41	113020338	Tube retour gaz
6	113100009	Fourreau sonde de température	42	116000073	Sonde passe pression
7	113100009	Clip de fixation sonde de température	43	113130021	Tube filtre au réservoir de stockage
8	117110004	Sonde de température dégivrage T3-TH2	44	120000066	Filtre
9	117230002	Réacteur	45	113060122	Tube vanne 4 voies
10	108560003	Pilier arrière gauche	46	116000068	Sonde haute pression
11	108560002	Cadre supérieur	47	113010244	Tube échappement
12	108480015	Pince de ceinture	48	117110021	Sonde température d'échappement T6-TH3
13	142000144	Courroie chauffante de l'évaporateur	49	121000006	Vanne 4 voies
14	108560011	Support ventilateur	50	113170032	Tube échangeur vers filtre
15	112000031	Moteur ventilateur	51	113120019	Tube du réservoir de stockage à EEV
16	132000023	Pâle ventilateur	52	113030108	Tube vanne 4 voies vers échangeur
17	1332600051	Panneau côté gauche	53	119000021	Détendeur électronique
18	1332600031	Panneau avant	54	113080056	EEV à la tuyauterie de distribution
19	108170017	Grille de protection ventilateur	55	150000110	Bouchon de vidange
20	108560036	Base	56	108010025	Clip de fixation sonde de température
21	101000185	Compresseur	57	117110012	Sonde de température d'arrivée d'eau T1-TH6
22	101000185	Pieds amortisseurs du compresseur	58	133020026	Joint raccord d'eau
23	142000077	Ceinture protection compresseur	59	133020011	Joint bleu
24	105000004	Chemin de câbles	60	102040703	Echangeur en titane
25	108560010	Panneau d'isolation	61	113900082	Raccord à visser
26	120000091	Vanne gaz	62	117110011	Sonde de température de sortie d'eau T2-TH5
27	108560034	Valve gaz panneau	63	136020083	Joint détecteur de débit
28	113100008	Tuyau de cuivre	64	112100021-1	Détecteur de débit
29	108010065	Platine boîtier de raccordement	65	133020012	Joint rouge
30	133030011	Boîtier de connexion	66	117010095	Module Modbus
31	136010004	Clip de fixation sonde de température	67	117240002	Anneau magnétique
32	106000011	Manomètre	68	117240003	Anneau magnétique
33	1332500051	Blocs de jonction en plastique	69	108560012	Coffret électrique
34	115000004	Bornier de connexion	70	117100048	Carte électronique
35	117020180	Contrôleur	71	108540006	Couvercle de boîte électrique
36	113712007	Couvercle de protection			

9.10 Modèle : 71682,71683

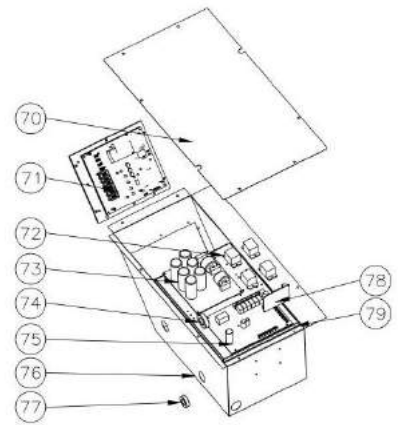
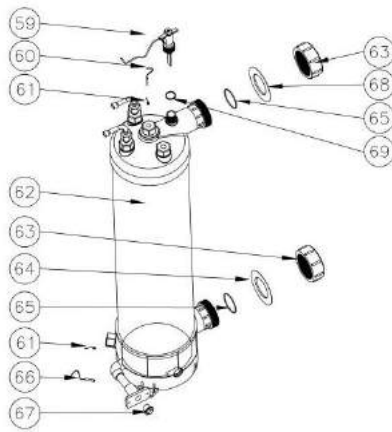
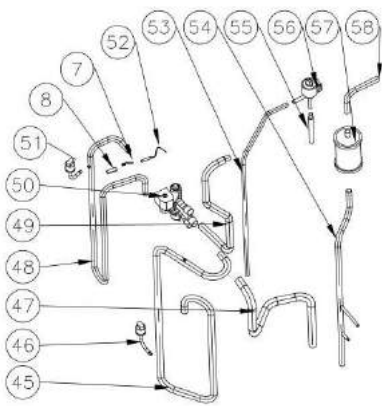
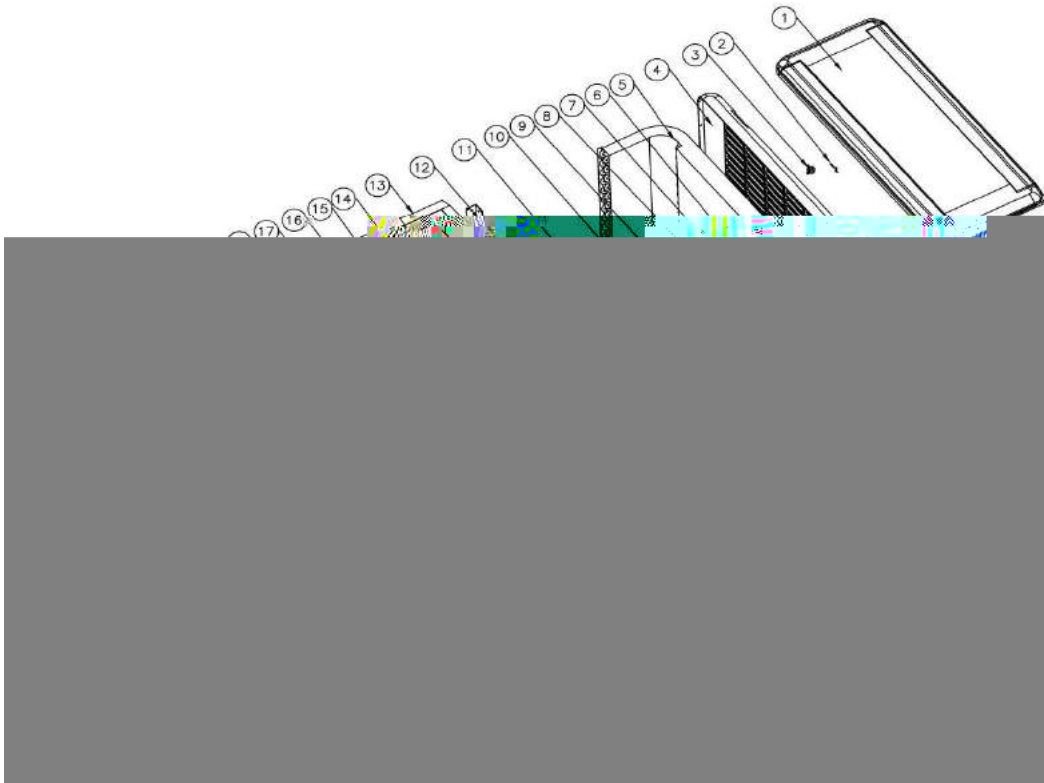

9.11 Liste des pièces détachées :

Modèle : 71682

NO	ERP	Désignation	NO	ERP	Désignation
1	133100001	Panneau supérieur	41	117020180	Contrôleur
2	117110020	Sonde de température ambiante T5-TH1	42	113712007	Couvercle de protection
3	133020010	Clip de fixation sonde température	43	103000208	Tube gaz
4	133250003	Panneau arrière	44	136020005	Bloc de caoutchouc
5	103000208	Evaporateur	45	113020326	Tube retour gaz
6	117110004	Sonde de température dégivrage T3-TH2	46	116000073	Sonde passe pression
7	113100009	Clip de fixation sonde de température	47	113060083	Tube vanne 4 voies
8	113100009	Fourreau sonde de température	48	113010227	Tube échappement
9	103000208	Tuyauterie de distribution	49	113030087	Tube vanne 4 voies vers échangeur
10	108120036	Panneau d'isolation	50	121000009	Vanne 4 voies
11	117230001	Réacteur	51	116000008	Sonde haute pression
12	108120035	Pilier arrière gauche	52	117110021	Sonde température d'échappement T6-TH3
13	108120034	Cadre supérieur	53	113120020	Tube du réservoir de stockage à EEV
14	108120044	Support ventilateur	54	113130020	Tube filtre au réservoir de stockage
15	108480015	Pince de ceinture	55	113080055	EEV à la tuyauterie de distribution
16	142000079	Courroie chauffante de l'évaporateur	56	119000021	Détendeur électronique
17	108550009	Pilier arrière gauche	57	120000066	Filtre
18	112000031	Moteur ventilateur	58	113170028	Tube échangeur vers filtre
19	132000015	Pâle ventilateur	59	112100021-1	Détecteur de débit
20	108010024	Cache de tube de moteur à courant continu	60	117110011	Sonde de température de sortie d'eau T2-TH5
21	133250004	Panneau côté gauche	61	108010025	Clip de fixation sonde de température
22	133250001	Panneau avant	62	102040749	Echangeur en titane
23	108010014	Grille de protection ventilateur	63	113900082	Raccord à visser
24	120000091	Vanne gaz	64	133020012	Joint bleu
25	113100008	Tuyau de cuivre	65	133020026	Joint raccord d'eau
26	101000185	Compresseur	66	117110012	Sonde de température d'arrivée d'eau T1-TH6
27	101000185	Pieds amortisseurs du compresseur	67	150000110	Bouchon de vidange
28	105000008	Chemin de câbles	68	133020011	Joint rouge
29	142000077	Ceinture protection compresseur	69	136020083	Joint détecteur de débit
30	108550005	Base	70	108120040	Couvercle de boîte électrique
31	108550008	Poignée pilier	71	117140016	Carte conducteur
32	108010065	Platine boîtier de raccordement	72	142000038	Relais
33	133250002	Panneau côté droit	73	117260001	Panneau filtrant
34	115000025	Terminal à 3 places pour l'électricité	74	117240002	Anneau magnétique
35	106000011	Manomètre	75	117250007	Carte électronique
36	136010004	Clip de fixation sonde de température	76	108120038	Coffret électrique
37	108550006	Pilier arrière gauche	77	117240003	Anneau magnétique
38	115000027	Terminal 3 places pour pompe à eau	78	117010095	Module Modbus
39	133250005	Blocs de jonction en plastique	79	108120039	Tableau d'échelle
40	133030011	Boîtier de connexion			

9.12 Liste des pièces détachées :

Modèle : 71683

NO	ERP	Désignation	NO	ERP	Désignation
1	133100001	Panneau supérieur	41	117020180	Contrôleur
2	117110020	Sonde de température ambiante T5-TH1	42	113712007	Couvercle de protection
3	133020010	Clip de fixation sonde température	43	103000209	Tube gaz
4	133250003	Panneau arrière	44	136020005	Bloc de caoutchouc
5	103000209	Evaporateur	45	113020389	Tube retour gaz
6	117110004	Sonde de température dégivrage T3-TH2	46	116000073	Sonde passe pression
7	113100009	Clip de fixation sonde de température	47	113060083	Tube vanne 4 voies
8	113100009	Fourreau sonde de température	48	113010228	Tube échappement
9	103000209	Tuyauterie de distribution	49	113030087	Tube vanne 4 voies vers échangeur
10	108120036	Panneau d'isolation	50	121000009	Vanne 4 voies
11	117230001	Réacteur	51	116000008	Sonde haute pression
12	108120035	Pilier arrière gauche	52	117110021	Sonde température d'échappement T6-TH3
13	108120034	Cadre supérieur	53	113120020	Tube du réservoir de stockage à EEV
14	108120044	Support ventilateur	54	113130020	Tube filtre au réservoir de stockage
15	108480015	Pince de ceinture	55	113080055	EEV à la tuyauterie de distribution
16	142000079	Courroie chauffante de l'évaporateur	56	119000042	Détendeur électronique
17	108550009	Pilier arrière gauche	57	120000066	Filtre
18	112000031	Moteur ventilateur	58	113170028	Tube échangeur vers filtre
19	132000015	Pâle ventilateur	59	112100021-1	Détecteur de débit
20	108010024	Cache de tube de moteur à courant continu	60	117110011	Sonde de température de sortie d'eau T2-TH5
21	133250004	Panneau côté gauche	61	108010025	Clip de fixation sonde de température
22	133250001	Panneau avant	62	102040754	Echangeur en titane
23	108010014	Grille de protection ventilateur	63	113900082	Raccord à visser
24	120000091	Vanne gaz	64	133020012	Joint bleu
25	113100008	Tuyau de cuivre	65	133020026	Joint raccord d'eau
26	101000186	Compresseur	66	117110012	Sonde de température d'arrivée d'eau T1-TH6
27	101000186	Pieds amortisseurs du compresseur	67	150000110	Bouchon de vidange
28	105000008	Chemin de câbles	68	133020011	Joint rouge
29	142000077	Ceinture protection compresseur	69	136020083	Joint détecteur de débit
30	108470069	Base	70	108120040	Couvercle de boîte électrique
31	108550008	Poignée pilier	71	117140016	Carte conducteur
32	108010065	Platine boîtier de raccordement	72	142000038	Relais
33	133250002	Panneau côté droit	73	117260001	Panneau filtrant
34	115000025	Terminal à 3 places pour l'électricité	74	117240002	Anneau magnétique
35	106000011	Manomètre	75	117250007	Carte électronique
36	136010004	Clip de fixation sonde de température	76	108120038	Coffret électrique
37	108550006	Pilier arrière gauche	77	117240003	Anneau magnétique
38	115000027	Terminal 3 places pour pompe à eau	78	117010095	Module Modbus
39	133250005	Blocs de jonction en plastique	79	108120039	Tableau d'échelle
40	133030011	Boîtier de connexion			

9.13 Modèle : 68821/68822/68823

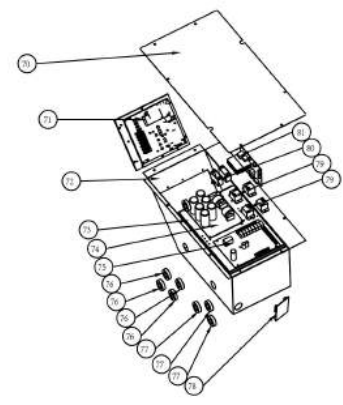
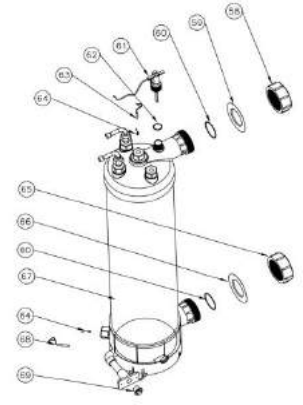
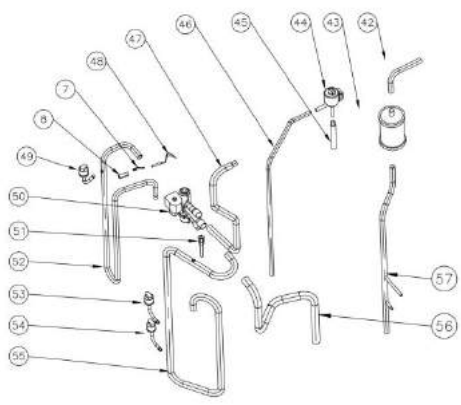
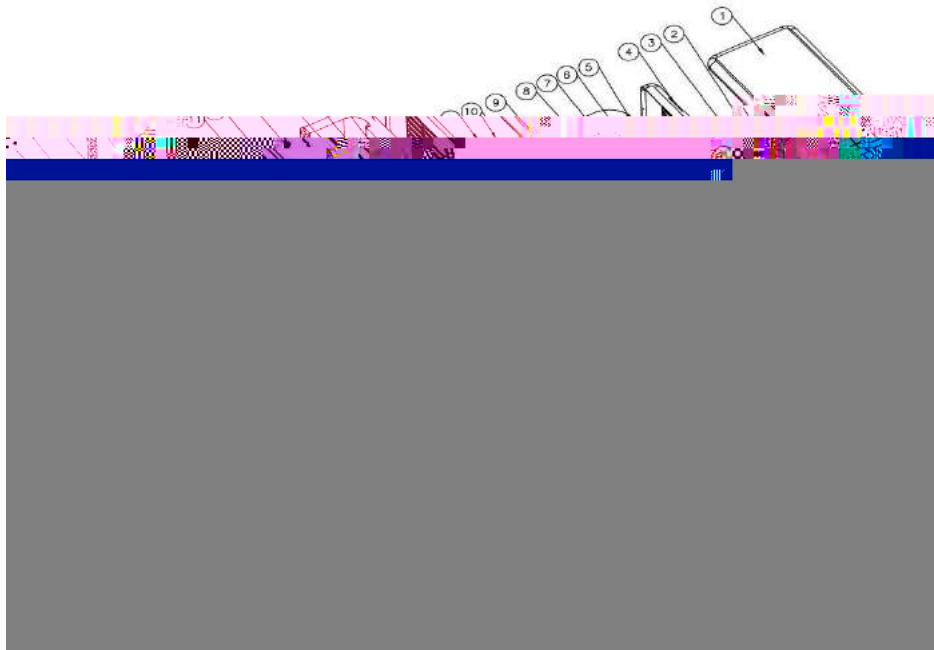

9.14 Liste des pièces détachées : 68821

NO	ERP	Désignation	NO	ERP	Désignation
1	133100001	Panneau supérieur	41	113050109	Tube gaz
2	117110020	Sonde de température ambiante T5-TH1	42	113170028	Tube échangeur vers filtre
3	133020010	Clip de fixation sonde température	43	120000066	Filtre
4	133250003	Panneau arrière	44	119000022	Détendeur électronique
5	103000153	Evaporateur	45	113080055	Distribution gaz
6	117110004	Sonde de température dégivrage T3-TH2	46	113120020	Tube du réservoir de stockage à EEV
7	113190001	Clip de fixation sonde de température	47	113030087	Tube vanne 4 voies vers échangeur
8	113190001	Fourreau sonde de température	48	117110021	Sonde température d'échappement T6-TH3
9	113040101	Distribution gaz	49	116000008	Sonde haute pression
10	108550010	Panneau d'isolation	50	121000009	Vanne 4 voies
11	117230002	Réacteur	51	120000023	Valve gaz
12	108120034	Cadre supérieur	52	113010158	Tube échappement
13	108120035	Pilier arrière gauche	53	116000080	Sonde passe pression 0.2-0.35
14	108120037	Support ventilateur	54	116000079	Sonde passe pression 0.1-0.3
15	112000031	Moteur ventilateur	55	113020245	Tube retour gaz
16	108010024	Couvercle moteur ventilateur	56	113060083	Tube vanne 4 voies
17	132000015	Pâle ventilateur	57	113130015	Tube filtre au réservoir de stockage
18	133250004	Panneau côté gauche	58	113900082	Raccord à visser
19	133250001	Panneau avant	59	133020011	Joint rouge
20	108010014	Grille de protection ventilateur	60	133020026	Joint raccord d'eau
21	108550009	Pilier arrière gauche	61	112100021-1	Détecteur de débit
22	108550005	Base	62	116000001-2	Joint détecteur de débit
23	101000149	Compresseur	63	117110011	Sonde de température de sortie d'eau T2-TH5
24	105000008	Chemin de câbles	64	108010025	Clip de fixation sonde de température
25	142000077	Ceinture protection compresseur	65	113900082	Raccord à visser
26	101000149	Pieds amortisseurs du compresseur	66	133020012	Joint bleu
27	108550008	Support poigné	67	102040503	Echangeur en titane
28	108010065	Platine boîtier de raccordement	68	117110012	Sonde de température d'arrivée d'eau T1-TH6
29	110000008	Passe câble	69	150000110	Bouchon de vidange
30	108010018	Boîtier de connexion	70	108120040	Couvercle de protection
31	133250002	Panneau côté droit	71	117140003	Carte électronique de puissance
32	115000025	Bornier de connexion	72	108120038	Coffret électrique
33	110800001	Manomètre	73	108120039	Platine
34	136010004	Clip de fixation sonde de température	74	117260002	Carte électronique de commande
35	108550006	Pilier arrière gauche	75	117250001-V 1.5	Carte électronique
36	115000027	Bornier de connexion	76	117240002	Anneau magnétique
37	133250005	Couvercle de protection	77	117240003	Anneau magnétique
38	113712007	Couvercle de protection	78	117010095	Module Modbus
39	117020150	Contrôleur	79	142000038	Contacteur
40	136020005	Pieds amortisseurs du compresseur	80	N/A	N/A
			81	117140006	Fan motor driver board

9.15 Liste des pièces détachées : 68822

NO	ERP	Désignation	N	ERP	Désignation
1	133100001	Panneau supérieur	41	113050110	Tube gaz
2	117110020	Sonde de température ambiante T5-TH1	42	113170028	Tube échangeur vers filtre
3	133020010	Clip de fixation sonde température	43	120000066	Filtre
4	133250003	Panneau arrière	44	119000022	Détenteur électronique
5	103000154	Evaporateur	45	113080055	Distribution gaz
6	117110004	Sonde de température dégivrage T3-TH2	46	113120020	Tube du réservoir de stockage à EEV
7	113190001	Clip de fixation sonde de température	47	113030087	Tube vanne 4 voies vers échangeur
8	113190001	Fourreau sonde de température	48	117110021	Sonde température d'échappement T6-TH3
9	113040102	Distribution gaz	49	116000008	Sonde haute pression
10	108550010	Panneau d'isolation	50	121000009	Vanne 4 voies
11	117230004	Réacteur	51	120000023	Vanne gaz
12	108120034	Cadre supérieur	52	113010158	Tube échappement
13	108120035	Pilier arrière gauche	53	116000080	Sonde passe pression 0.2-0.35
14	108120037	Support ventilateur	54	116000079	Sonde passe pression 0.1-0.3
15	112000031	Moteur ventilateur	55	113020245	Tube retour gaz
16	108010024	Couvercle moteur ventilateur	56	113060083	Tube vanne 4 voies
17	132000015	Pâle ventilateur	57	113130015	Tube filtre au réservoir de stockage
18	133250004	Panneau côté gauche	58	113900082	Raccord à visser
19	133250001	Panneau avant	59	133020011	Joint rouge
20	108010014	Grille de protection ventilateur	60	133020026	Joint raccord d'eau
21	108550009	Pilier arrière gauche	61	112100021-1	Détecteur de débit
22	108550005	Base	62	116000001-2	Joint détecteur de débit
23	101000122	Compresseur	63	117110011	Sonde de température de sortie d'eau T2-TH5
24	105000008	Chemin de câbles	64	108010025	Clip de fixation sonde de température
25	142000077	Ceinture protection compresseur	65	113900082	Raccord à visser
26	101000122	Pieds amortisseurs du compresseur	66	133020012	Joint bleu
27	108550008	Support poigné	67	102040502	Echangeur en titane
28	108010065	Platine boîtier de raccordement	68	117110012	Sonde de température d'arrivée d'eau T1-TH6
29	110000008	Passe câble	69	150000110	Bouchon de vidange
30	108010018	Boîtier de connexion	70	108120040	Couvercle de protection
31	133250002	Panneau côté droit	71	117140002	Carte électronique de puissance
32	115000025	Bornier de connexion	72	108120038	Coffret électrique
33	110800001	Manomètre	73	108120039	Platine
34	136010004	Clip de fixation sonde de température	74	117260001	Carte électronique de commande
35	108550006	Pilier arrière gauche	75	117250001-V 1.5	Carte électronique
36	115000027	Bornier de connexion	76	117240002	Anneau magnétique
37	133250005	Couvercle de protection	77	117240003	Anneau magnétique
38	113712007	Couvercle de protection	78	117010095	Module Modbus
39	117020150	Contrôleur	79	142000038	Contacteur
40	136020005	Pieds amortisseurs du compresseur	80	N/A	N/A
			81	N/A	N/A

9.16 Liste des pièces détachées : 68823

NO	ERP	Désignation	NO	ERP	Désignation
1	133100001	Panneau supérieur	41	113050110	Tube gaz
2	117110020	Sonde de température ambiante T5-TH1	42	113170028	Tube échangeur vers filtre
3	133020010	Clip de fixation sonde température	43	120000066	Filtre
4	133250003	Panneau arrière	44	119000022	Détendeur électronique
5	103000154	Evaporateur	45	113080055	Distribution gaz
6	117110004	Sonde de température dégivrage T3-TH2	46	113120020	Tube du réservoir de stockage à EEV
7	113190001	Clip de fixation sonde de température	47	113030087	Tube vanne 4 voies vers échangeur
8	113190001	Fourreau sonde de température	48	117110021	Sonde température d'échappement T6-TH3
9	113040102	Distribution gaz	49	116000008	Sonde haute pression
10	108550010	Panneau d'isolation	50	121000009	Vanne 4 voies
11	117230002	Réacteur	51	120000023	Valve gaz
12	108120034	Cadre supérieur	52	113010158	Tube échappement
13	108120035	Pilier arrière gauche	53	116000080	Sonde passe pression 0.2-0.35
14	108120037	Support ventilateur	54	116000079	Sonde passe pression 0.1-0.3
15	112000031	Moteur ventilateur	55	113020245	Tube retour gaz
16	108010024	Couvercle moteur ventilateur	56	113060083	Tube vanne 4 voies
17	132000015	Pâle ventilateur	57	113130015	Tube filtre au réservoir de stockage
18	133250004	Panneau côté gauche	58	113900082	Raccord à visser
19	133250001	Panneau avant	59	133020011	Joint rouge
20	108010014	Grille de protection ventilateur	60	133020026	Joint raccord d'eau
21	108550009	Pilier arrière gauche	61	112100021-	Détecteur de débit
22	108550005	Base	62	116000001-	Joint détecteur de débit
23	101000149	Compresseur	63	117110011	Sonde de température de sortie d'eau T2-TH5
24	105000008	Chemin de câbles	64	108010025	Clip de fixation sonde de température
25	142000077	Ceinture protection compresseur	65	113900082	Raccord à visser
26	101000149	Pieds amortisseurs du compresseur	66	133020012	Joint bleu
27	108550008	Support poigné	67	102040502	Echangeur en titane
28	108010065	Platine boîtier de raccordement	68	117110012	Sonde de température d'arrivée d'eau T1-TH6
29	110000008	Passe câble	69	150000110	Bouchon de vidange
30	108010018	Boîtier de connexion	70	108120040	Couvercle de protection
31	133250002	Panneau côté droit	71	117140003	Carte électronique de puissance
32	115000006	Bornier de connexion	72	108120038	Coffret électrique
33	110800001	Manomètre	73	108120039	Platine
34	136010004	Clip de fixation sonde de température	74	117260002	Carte électronique de commande
35	108550006	Pilier arrière gauche	75	117250001- V1.5	Carte électronique
36	115000027	Bornier de connexion	76	117240002	Anneau magnétique
37	133250005	Couvercle de protection	77	117240003	Anneau magnétique
38	113712007	Couvercle de protection	78	117010095	Module Modbus
39	117020150	Contrôleur	79	142000038	Contacteur
40	136020005	Pieds amortisseurs du compresseur	80	N/A	N/A
			81	117140006	Carte pilote de moteur de ventilateur

9.17 Entretien

- (1) Vous devez vérifier le circuit d'eau régulièrement pour éviter l'air entrant dans le circuit et la présence de faible débit d'eau, car cela réduit les performances et la fiabilité de la pompe à chaleur.
- (2) Nettoyez votre piscine et le système de filtration régulièrement.
- (3) Vous devez vidanger l'eau de pompe à chaleur, pour empêcher des dommages du gel au cours de l'hiver et/ou pendant une longue période d'inactivité.
- (4) Remplir entièrement le circuit d'eau avant de faire fonctionner l'unité à nouveau.
- (5) Lorsque l'unité est en cours de fonctionnement, il y aura toujours un peu d'eau de condensation répandue en dessous.
- (6) L'action de remplissage de gaz doit être effectuée par un professionnel habilité muni d'une licence d'exploitation R32.
- (7) Veuillez remplir le gaz R32 de la vanne à soupape à l'intérieur de la machine.



Zwembad warmtepomp

PRO ELYO INVERBOOST NN

1. Afmetingen
2. Transport en opslag
3. Specificaties
4. Toebehoren lijst
5. Installatie en aansluiting
6. Elektrisch schema
7. Gebruik en werking
8. Problemen
9. Opengeklapt diagram

Dank u voor het gebruiken van de zwembad warmtepomp voor uw zwembad verwarming, het zal uw zwembadwater verwarmen en het op een constante temperatuur houden wanneer de omgevingstemperatuur -20 tot 50°C.



LET OP: Deze gebruiksaanwijzing bevat alle benodigde informatie voor het gebruik en de installatie van uw warmtepomp.

De installateur moet de gebruiksaanwijzing lezen en de instructies zorgvuldig volgen bij plaatsing en onderhoud.

De installateur is verantwoordelijk voor de installatie van het product en moet alle instructies opvolgen van de fabrikant en de regels in toepassing. Verkeerde installatie niet volgens de gebruiksaanwijzing heeft uitsluiting van de gehele garantie tot gevolg.

De fabrikant verwerpt elke verantwoordelijkheid voor de schade veroorzaakt door de mensen, objecten en of de fouten wegens de installatie die niet de aanwijzing van de gebruiksaanwijzing volgen. Elk gebruik zonder bevestiging bij het begin van de fabricatie zal beschouwd worden als gevaarlijk.

WAARSCHUWING: Verwijder alstublieft altijd het water in de warmtepomp tijdens de wintertijd of wanneer de omgevingstemperatuur daalt beneden 0°C, of anders zal de titanium wisselaar beschadigd raken of bevroren, in dit geval, zal uw garantie eindigen.

WAARSCHUWING: Sluit alstublieft altijd de stroom af als u de kast wilt openen om de warmtepomp binnen te bereiken, omdat er een hoog voltage stroom aanwezig is.

WAARSCHUWING: P Houdt alstublieft het scherm van de besturing in een droge omgeving, of sluit de isolatie bedekking goed om het scherm van de besturing te beschermen tegen beschadiging door vochtigheid.

Belangrijke mededeling

- Houd de warmtepomp altijd op de ventilatieplaats en uit de buurt van alles dat brand zou kunnen veroorzaken.
- Las de buis niet als er koelmiddel in de machine zit. Houd de machine uit de besloten ruimte wanneer u gas vult.
- De buis moet worden gestofzuigd voordat R32 gas van de afsluitklep in de machine wordt gevuld.

1. Afmetingen

1.1 Inhoud van het pakket

Voor de toepassing, zult u met uw warmtepomp PRO ELYO, volgende componenten vinden:

- Hydraulische overgangen IN/OUT in 50 mm (2 stuks)
- Installatie en Instructie Handleiding
- Waterdrainage flexibel buizen
- Kabel van 10 meters om de bedieningspaneel te deporteren
- Watervaste kist
- Hoes voor de overwintering
- Anti-vibration schaatsen (4 stuks)

1.2 Afmetingen

Model: 71676

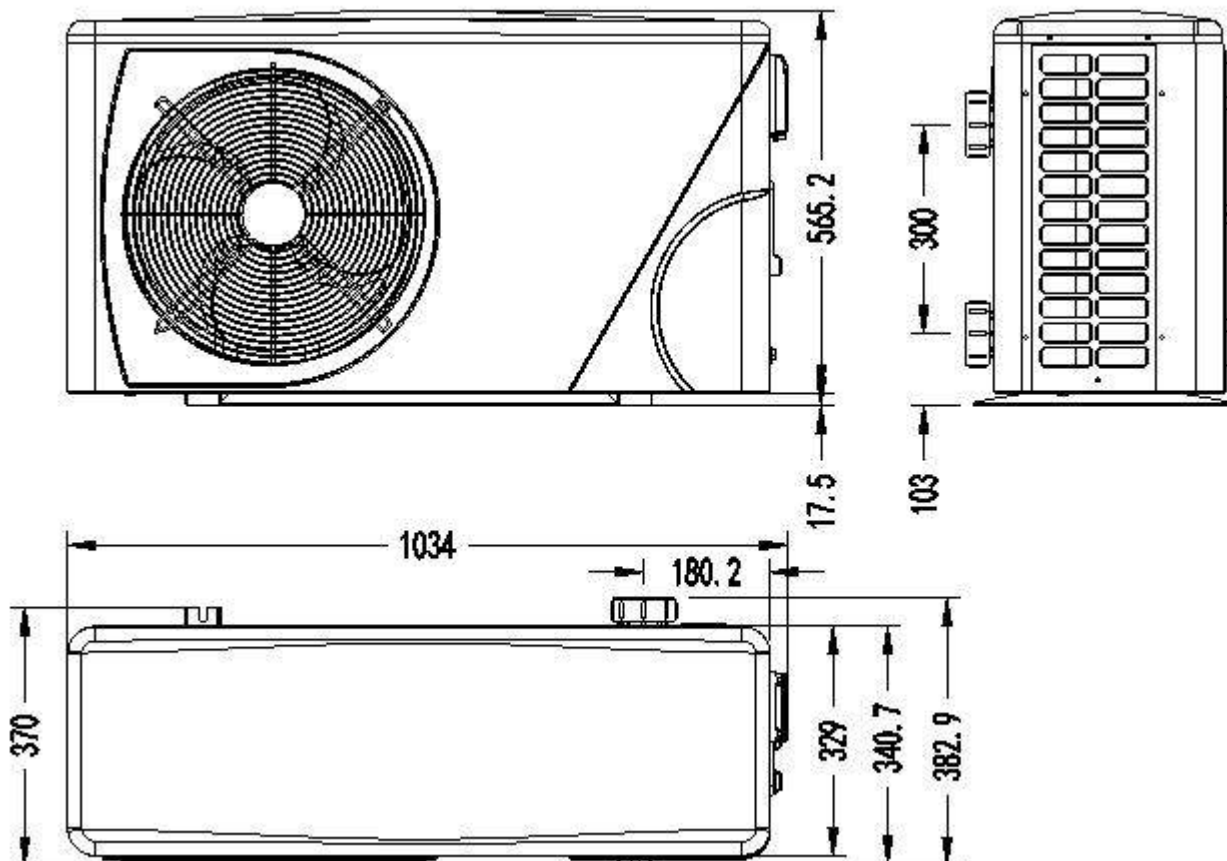

Model:71677/71678/71679

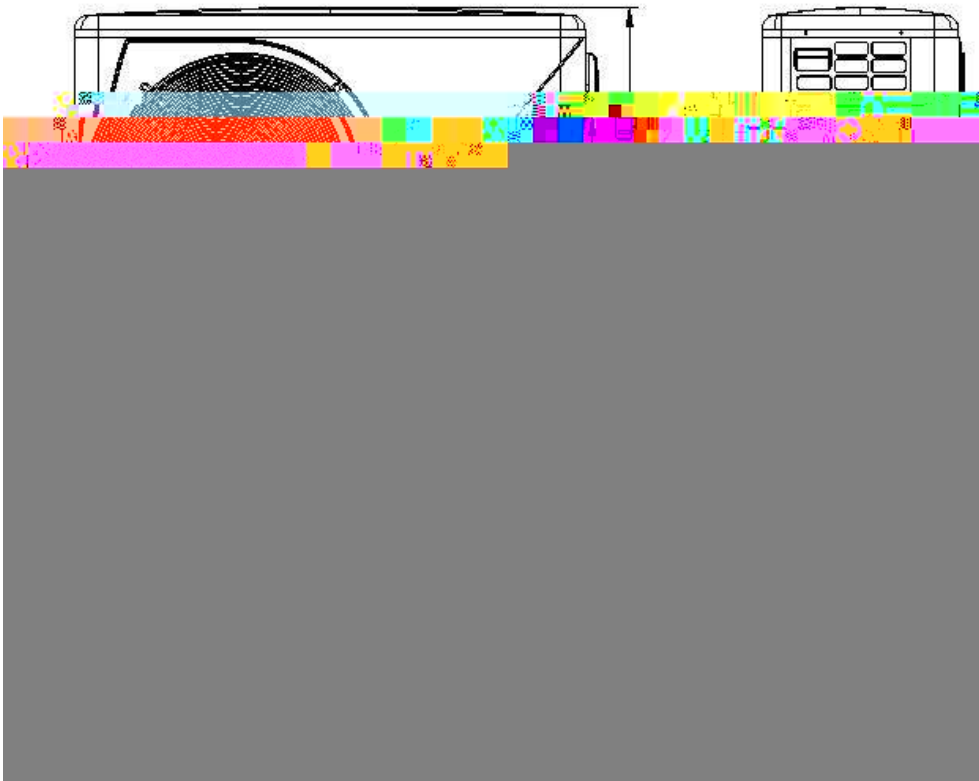

Model:71680/71681

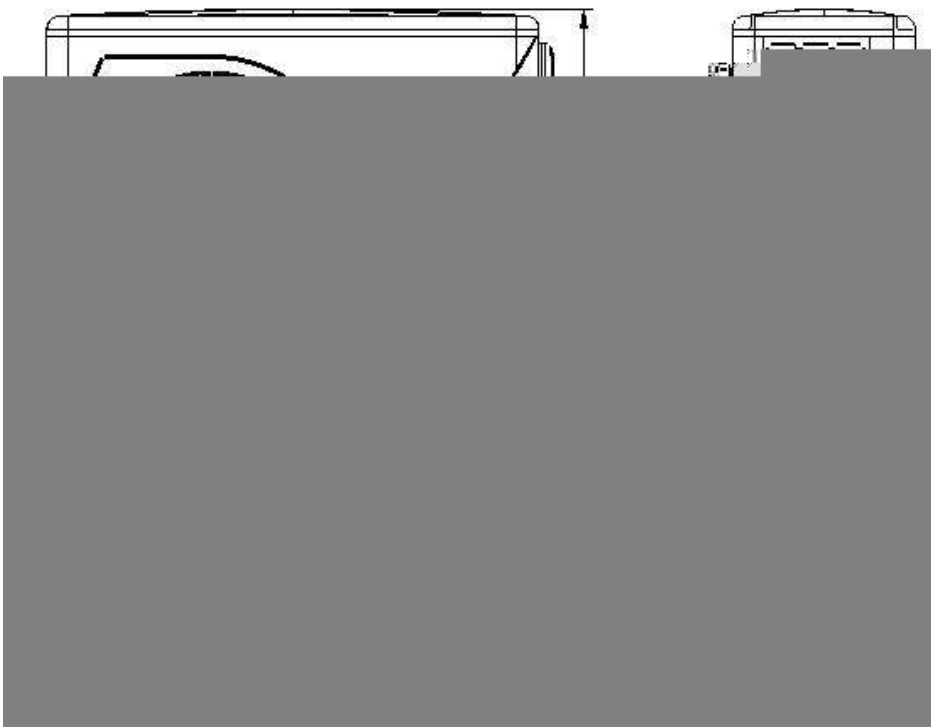

Model: 71682/71683/68821/68822/68823



2.1 Transport



Voor het transport, wordt de warmtepomp in fabriek op een palet bepaald en door een karton beschermd. Teneinde de schade te vermijden, moet de warmtepomp vervoerd worden verpakt op zijn palet.

Zelfs wanneer het vervoer ten laste van de leverancier is, kan elk materiaal bij zijn transport bij de klant beschadigd worden en hij is van de verantwoordelijkheid van de ontvanger om zich van de overeenstemming van de levering te verzekeren. De ontvanger moet bezwaren uiten schriftelijk aan de ontvangst op de leveringsbron als hij verslechtingen van de verpakking vaststelt. **NIET VERGETEN OM PER AANGETEKENE BRIEF AAN DE EXPEDITEUR ONDER 48 UUR TE BEVESTIGEN.**

2.2 Opslag



Technische gegevens PRO ELYO INVERBOOST NN zwembadwarmtepompen

CE-norm, R32, ABS-kast

MODEL		PROELYXP07i	PROELYXP09i	PROELYXP11i	PROELYXP14i
CODE		71676	71677	71678	71679
*Prestaties bij Air 28 °C, het water 28 °C, luchtvochtigheid 80%					
Verwarmingscapaciteit	Kw	7-3.1	9-2.3	11-2.9	14-3.2
Energieverbruik	Kw	1.04-0.21	1.34-0.14	1.64-0.18	2.09-0.2
C.O.P.		15-6.7	16-6.7	16-6.7	16-6.7
* Prestaties bij Air 15 °C, het water 26 °C, luchtvochtigheid 70%					
Verwarmingscapaciteit	Kw	4.7-2.5	6.6-1.9	7.9-2	9.5-2.3
Energieverbruik	Kw	0.94-0.32	1.32-0.24	1.58-0.25	1.9-0.29
C.O.P.		7.9-5	8.0-5	8.0-5	8.0-5
* Prestaties bij Air 0 °C, het water 26 °C, luchtvochtigheid 78%					
Verwarmingscapaciteit	Kw	3.44-1.7	4.11-2.3	5.54-3.0	6.85-3.8
Energieverbruik	Kw	1.23-0.38	1.47-0.82	1.98-0.68	2.45-0.85
C.O.P.		4.5-2.8	4.4-2.8	4.4-2.8	4.5-2.8
* Prestaties bij Air -10 °C, het water 26 °C, luchtvochtigheid 78%					
Verwarmingscapaciteit	Kw	2.41-1.5	3.13-2.0	3.87-2.7	5.1-3.15
Energieverbruik	Kw	1.21-0.35	1.42-0.53	1.76-0.69	2.32-0.81
C.O.P.		4.3-2	3.8-2.2	3.9-2.2	3.9-2.2
* Algemene data					
Compressor		MITSUBISHI INVERTER COMPRESSOR			
Voltage	V	220-240V/50Hz or 60Hz/1PH			
Nominale stroom	A	4.6	5.9	7.2	9.2
Minimale zekering	A	7	9	11	14
Aanbevolen poolvolume	m ³	10-26	12-35	16-60	18-66
Geadviseerde waterflux	m ³ /h	2.5	3.0	3.7	4.0
Waterdrukval	Kpa	12	12	14	15
Warmtewisselaar		Twist-titanium tube in PVC			
Wateraansluiting	mm	50			
Fan hoeveelheid		1			
Ventilatie type		Horizontal			
Ventilator snelheid	RPM	500-850		550-850	
Ingangsvermogen van Fan	W	6-35		22-82	32-110
Geluidsniveau (10m)	dB(A)	≤ 41	≤ 42	≤ 42	≤ 43
Geluidsniveau (1m)	dB(A)	38-51	39-52	40-52	40-54
Koelmiddel (R32)	g	650	700	1000	1100
CO2 gelijkwaardig	Tonne	0.44	0.47	0.68	0.74
* Afmetingen / gewicht					
Netto gewicht	kg	56	68	73	78
Bruto gewicht	kg	68	73	78	83
Net dimensie	mm	1008*380*577	1050*440*709		
Verpakking dimensie	mm	1095*430*705	1130*470*850		

Technische gegevens PRO ELYO INVERBOOST NN zwembadwarmtepompen

CE-norm, R32, ABS-kast

MODEL		PROELYXP16i	PROELYXP20i	PROELYXP26i	PROELYXP30i
CODE		71680	71681	71682	71683
* Prestaties bij Air 28 °C, het water 28 °C, luchtvochtigheid 80%					
Verwarmingscapaciteit	Kw	16-3.8	20-4.7	26-5.9	30-6.8
Energieverbruik	Kw	2.39-0.24	2.99-0.29	3.88-0.37	4.55-0.43
C.O.P.		16-6.7	16-6.7	16-6.7	16-6.6
* Prestaties bij Air 15 °C, het water 26 °C, luchtvochtigheid 70%					
Verwarmingscapaciteit	Kw	11.2-3	14-3.9	18-5.4	22.8-5.6
Energieverbruik	Kw	2.24-0.38	2.8-0.49	3.6-0.68	4.56-0.68
C.O.P.		8.2-5	8.2-5	8.2-5	8.2-5
* Prestaties bij Air 0 °C, het water 26 °C, luchtvochtigheid 78%					
Verwarmingscapaciteit	Kw	7.4-4.1	9.79-4.8	13-6.7	15.89-8.5
Energieverbruik	Kw	2.64-0.91	3.5-1.09	4.64-1.52	5.68-1.93
C.O.P.		4.5-2.8	4.4-2.8	4.4-2.8	4.4-2.8
* Prestaties bij Air -10 °C, het water 26 °C, luchtvochtigheid 78%					
Verwarmingscapaciteit	Kw	5.8-3.6	7.58-4.3	10.4-5.9	12.74-7.4
Energieverbruik	Kw	2.64-0.92	3.45-1.1	4.73-1.51	5.79-1.95
C.O.P.		3.9-2.2	3.9-2.2	3.9-2.2	3.8-2.2
* Algemene data					
Compressor		MITSUBISHI INVERTER COMPRESSOR			
Spanning	V	220-240V/50Hz or 60Hz/1PH			
Nominale stroom	A	10.5	13.2	17.0	23.0
Minimale zekering	A	16	20	26	35
Aanbevolen poolvolume	m ³	28-85	58-120	65-132	78-156
Geadviseerde waterflux	m ³ /h	5.0	6.0	8.0	10.0
Waterdrukval	Kpa	15	18	20	25
Warmtewisselaar		Twist-titanium tube in PVC			
Wateraansluiting	mm	50			
Fan hoeveelheid		1			
Ventilatie type		Horizontal			
Ventilator snelheid	RPM	450-650		(550-850)*2	
Ingangsvermogen van	W	35-130		(32-110)*2	
Geluidsniveau (10m)	dB(A)	≤ 43	≤ 45	≤ 49	≤ 49
Geluidsniveau (1m)	dB(A)	40-54	41-56	42-60	42-60
Koelmiddel (R32)	g	1500	1900	2000	2600
CO2 gelijkwaardig	Tonne	1.01	1.28	1.35	1.76
* Afmetingen / gewicht					
Netto gewicht	kg	98	117	128	130
Bruto gewicht	kg	113	135	146	148
Net dimensie	mm	1050*450*870		1050*452*1295	
Verpakking dimensie	mm	1140*480*1010		1130*515*1430	

* Bovenstaande gegevens kunnen zonder voorafgaande kennisgeving worden gewijzigd.

Technische gegevens PRO ELYO INVERBOOST NN zwembadwarmtepompen

CE-norm, R410A, ABS-kast

MODEL		Pro Elyo Inverboost NN26T	Pro Elyo Inverboost NN 35	Pro Elyo Inverboost NN35T
CODE		68821	68822	68823
* Prestaties bij Air 28 °C, het water 28 °C, luchtvochtigheid 80%				
Verwarmingscapaciteit	Kw	26-5.9	35-8	35-8
Energieverbruik	Kw	3.88-0.37	5.22-0.5	5.22-0.5
C.O.P.		16-6.7	16-6.7	16-6.7
*Prestaties bij Air 15 °C, het water 26 °C, luchtvochtigheid 70%				
Verwarmingscapaciteit	Kw	18-5.4	24-5.6	24-5.6
Energieverbruik	Kw	3.6-0.68	4.8-0.68	4.8-0.68
C.O.P.		8.2-5	8.2-5	8.2-5
*Prestaties bij Air 0 °C, het water 26 °C, luchtvochtigheid 78%				
Verwarmingscapaciteit	Kw	13-6.7	15.8-3.7	15.8-3.7
Energieverbruik	Kw	4.64-1.52	4.46-0.63	4.46-0.63
C.O.P.		4.4-2.8	5.8-3.6	5.8-3.6
*Prestaties bij Air -10 °C, het water 26 °C, luchtvochtigheid 78%				
Verwarmingscapaciteit	Kw	10.4-5.9	11.6-3.1	11.6-3.1
Energieverbruik	Kw	4.73-1.51	4.77-0.6	4.77-0.6
C.O.P.		3.9-2.2	5.2-2.45	5.2-2.45
* Algemene data				
Compressor		MITSUBISHI INVERTOR COMPRESSOR		
Voltage	V	380V/50Hz or 60Hz/3PH	220~240V /50Hz or 60Hz/1PH	380V/50Hz or 60Hz/3PH
Nominale stroom	A	7	22.9	8.4
Minimale zekering	A	10.5	34	13
Aanbevolen poolvolume (met afdekzeil)	m ³	65-132	78-160	78-160
Geadviseerde waterflux	m ³ /h	8.00	10.0	10.0
Waterdrukval	Kpa	20	25	25
Warmtewisselaar		Twist-titanium tube in PVC		
Wateraansluiting	mm	50		
Fan hoeveelheid		2		
Ventilatie type		Horizontal		
Ventilator snelheid	RPM	(550-850)*2		
Ingangsvermogen van	W	(32-110)*2		
Geluidsniveau (10m)	dB(A)	/	/	/
Geluidsniveau (1m)	dB(A)	42-60	42-60	42-60
Koelmiddel (R410a)	g	3800	4000	4000
CO2 gelijkwaardig	Tonne	7.94	8.36	8.36
* Afmetingen / gewicht				
Netto gewicht	kg	128		
Bruto gewicht	kg	146		
Net dimensie	mm	1050*452*1295		
Verpakking dimensie	mm	1130*515*1430		

* Bovenstaande gegevens kunnen zonder voorafgaande kennisgeving worden gewijzigd.

4.1 Toebehoren



Anti-vibratie schaatsen, 4 stuks



Aftap buis, 2 stuks



Watervaste kist, 1 stuk



10M Signaal draad, 1 stuk
Modbus signaaldraad, 1 st



Water drainagebuizen, 2 pcs



Winter Cover, 1 st

4.2 Toebehoren installatie



Anti-vibratie rubbers

1. Neem de 4 anti-vibratie rubbers eruit.
2. Plaats ze een voor een onder de bodem van de machine zoals op het plaatje.



Aftap buis

1. Installeer de aftap buis onder het bodempaneel.
 2. Verbindt het met een water buis om het water af te tappen.
- Opmerking: Til de warmtepomp op om de buis te installeren. Til de warmtepomp nooit te ver op, het kan de compressor beschadigen.



Water invoer & uitvoer verbinding

1. Gebruik de buis tape om de water invoer & uitvoer verbinding op de warmtepomp te verbinden .
2. Installeer de twee verbindingen zoals op het plaatje getoond.
3. Schroef ze op de water & uitvoer verbinding.

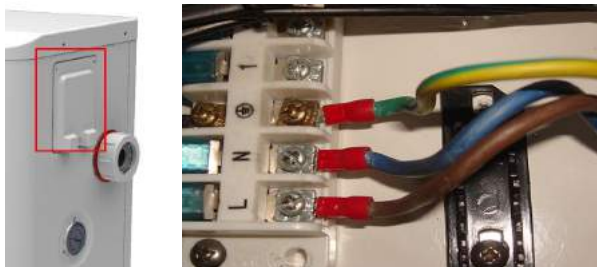

Bekabeling

1. Open het bedradingsstuk box (rood gemarkeerd) aan de zijde van de machine.
2. Bevestig de andere kant op de gewrichten in de elektrische schakelkast.

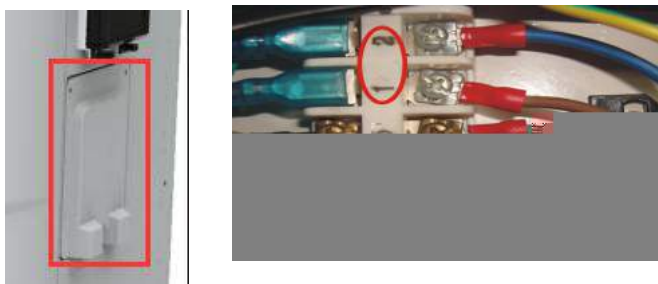

Waterpomp bedrading (droog contact)

1. Open het bedradingsstuk box (rood gemarkeerd) aan de zijde van de machine.
2. Bevestig de andere kant op de gewrichten in de elektrische schakelkast.

5. Installatie en aansluiting

5.1 Opmerkingen

De fabriek levert alleen de warmtepomp. Alle andere componenten, inclusief een bypass wanneer nodig, moeten geleverd worden door de gebruiker of de installateur.

Attentie:

Volg alstublieft de volgende regels wanneer u de warmtepomp installeert:

1. Elke toevoeging van chemicaliën moet plaatsvinden in de buizen gelokaliseerd **na** de warmtepomp.
2. Installeer een bypass als de afstand van de water toevoer van de zwembadpomp meer dan 20% groter is dan de toegestane toevoer door de warmtewisselaar of de warmtepomp.
3. Installeer de warmtepomp boven het waterniveau van het zwembad.
4. Plaats de warmtepomp altijd op een vaste ondergrond en gebruik de bijgevoegde demping rubbers om vibratie en geluid te vermijden.
5. Houdt de hele warmtepomp altijd recht . Als het apparaat in een diagonale positie was gehouden, wacht tenminste 24 uren met het starten van de warmtepomp.

5.2 Warmtepomp plaatsing

Het apparaat zal goed werken in elke gewenste locatie zolang de volgende drie onderdelen aanwezig zijn:

- 1. Frisse lucht** – **2. Elektriciteit** – **3. Zwembadfilters**

Het apparaat mag worden geïnstalleerd in virtueel elke **buiten** locatie zolang als de gespecificeerde minimumafstanden met andere objecten wordt aangehouden (zie tekening hieronder). Raadpleeg alstublieft uw installateur voor installatie met een zwembad binnenshuis. Installatie in een locatie met veel wind is helemaal geen probleem, wel in de situatie met een gasverwarming (inclusief waakvlam problemen).

ATTENTIE: Installeer het apparaat nooit in een afgesloten ruimte met een gelimiteerde luchthoeveelheid in waarde lucht uitgestoten door het apparaat weer hergebruikt wordt, of nabij bosschage dat de luchtinlaat kan blokkeren. Zulke locaties verhinderen de continue levering van frisse lucht, wat resulteert in een gereduceerde efficiëncie en mogelijk voldoende warmteafgifte tegengaat.

Zie de tekening hieronder voor minimumafstanden.

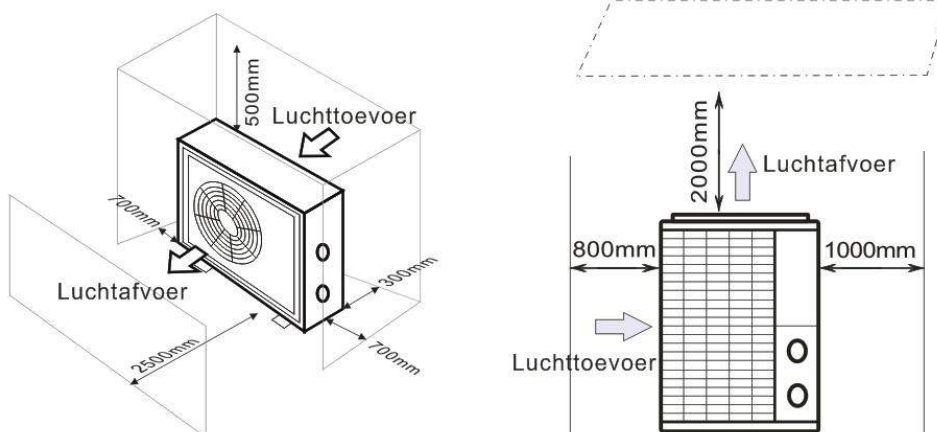

5.3 Afstand van uw zwembad

De warmtepomp wordt normaal geïnstalleerd binnen een bereik van 7.5 meter van het zwembad. Hoe groter de afstand van het zwembad, hoe groter het warmteverlies in de buizen. Als de buizen meestal ondergronds zijn, is het warmteverlies laag op afstanden tot 30 m (15 m van en naar de pomp; 30 m in totaal) tenzij de grond na het is of het grondwaterpeil hoog is. Een ruwe schatting van het warmteverlies per 30 m 0.6 Kwh (2,000 BTU) voor elke 5 °C verschil tussen de watertemperatuur in het zwembad en de temperatuur van de grond die de muis omringd. Dit verhoogt de werktijd met 3% tot 5%.

5.4 Controle klep installatie

Opmerking: als een automatische dosering apparaat voor chloor en zuur (pH) gebruikt wordt, is het belangrijk om de warmtepomp te beschermen tegen excessief hoge chemische concentraties die de warmtewisselaar kunnen laten corroderen. Om deze reden, moeten apparaten van deze soort altijd bevestigd worden aan de buizen **na** de warmtepomp, en het wordt aanbevolen om een controleklep te installeren om terugvloeien van het water te voorkomen in het geval van afwezigheid van watercirculatie.

Schade aan de warmtepomp veroorzaakt door nalatigheid van deze instructie is niet gedekt door de garantie.

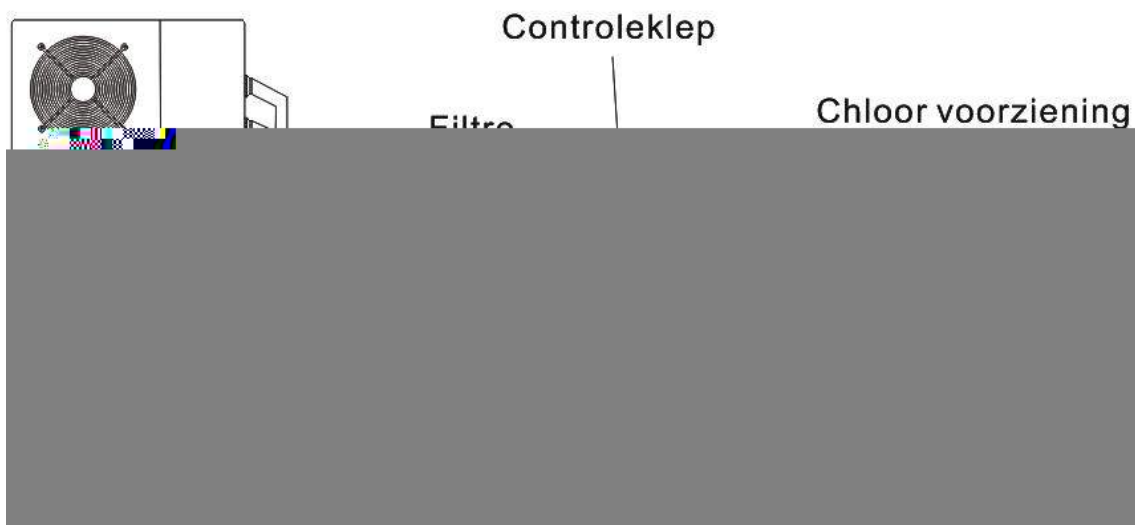

5.5 Typische opstelling

Opmerking: Deze opstelling is alleen een illustratief voorbeeld.

5.6 Initiële werking

Opmerking: Om het water in het zwembad (of hete kuip) te verwarmen, moet de filterpomp draaien om ervoor te zorgen dat het water circuleert door de warmtepomp. De warmtepomp zal niet opstarten als het water niet circuleert.

Nadat alle verbindingen gemaakt zijn en gecontroleerd, voer dan de volgende procedure uit:

1. Zet de filterpomp aan. Controleer op lekkage en verifieer dat het water stroomt van en naar het zwembad.
2. Sluit de stroom aan de waterpomp aan en druk op de aan/uit knop  op het elektronische controlepaneel. Het apparaat zou opstarten nadat de tijdvertraging voorbij is (zie onder).
3. Na een paar minuten, controleer of de lucht die uit het apparaat komt koeler is.
4. Wanneer de filterpomp uitgezet wordt, moet het apparaat ook automatisch afslaan, wanneer niet, stel dan de doorvoer schakelaar bij.

Afhankelijk van de initiële temperatuur van het water in het zwembad en de luchttemperatuur, kan het verscheidene dagen duren om het water te verwarmen tot de gewenste temperatuur. Een goede zwembad afdekking kan de benodigde lengte van tijd dramatisch inkorten.

Water doorvoer schakelaar:

Het is uitgerust met een doorvoer schakelaar om het HP-apparaat ervoor te beschermen dat het draait met een volgedaan water doorvoer snelheid. Het zal aangaan wanneer de zwembadpomp loopt en laat het stoppen wanneer de pomp stopt. Als het oppervlak van het zwembadwater hoger is dan 1 meter boven of beneden de automatische instelknop van de waterpomp, heeft u uw dealer nodig om de initiële opstart bij te stellen.

Tijdvertraging - De warmtepomp heeft een ingebouwde 3-minuten opstart vertraging om het circuit te beschermen en excessief contact verval te voorkomen. Het apparaat zal automatisch herstarten nadat deze tijdvertraging afloopt. Zelfs een korte stroomonderbreking zal deze tijdvertraging starten en voorkomen dat het apparaat onmiddellijk herstart. Meerdere stroomonderbrekingen tijdens deze vertraging periode hebben geen effect op de 3-minuten periode van de vertraging.

5.6 Condensatie

De lucht aangetrokken door de warmtepomp wordt sterk gekoeld door de werking van de warmtepomp om het water van het zwembad te verwarmen, wat condensatie kan veroorzaken op de bladen van de verdamper. De hoeveelheid condensatie kan zoveel zijn als verscheidene liters per uur bij hoge relatieve vochtigheid. Dit is soms foutief beschouwd als een water lekkage.

5.7 Manometer display (R32)

Bekijk de manometer die de koelgasdruk van de unit aangeeft, de onderstaande tabel toont de normale waarde van de gasdruk (R32) wanneer de machine uit staat of in bedrijf is.

Eenheidsvoorwaarde	Uitschakelen			
	omringend(°C)	-5~5	5~15	15~25
Watertemperatuur (°C)	/	/	/	/
Druk meter (Mpa)	0.59~0.85	0.85~1.18	1.18~1.59	1.59~2.1

Eenheidsvoorwaarde	hardlopen				
	omringend (°C)	/	/	/	/
Watertemperatuur (°C)	10~15	15~20	20~25	25~30	30~35
Druk meter (Mpa)	1.1~1.6	1.3~1.8	1.5~2.1	1.7~2.4	1.9~2.7

6. Elektrische bedrading

6.1 ZWEMBAD WARMTEPOMP BEDRADING SCHEMA

Réf. 71676/71677/71678/71679/71680

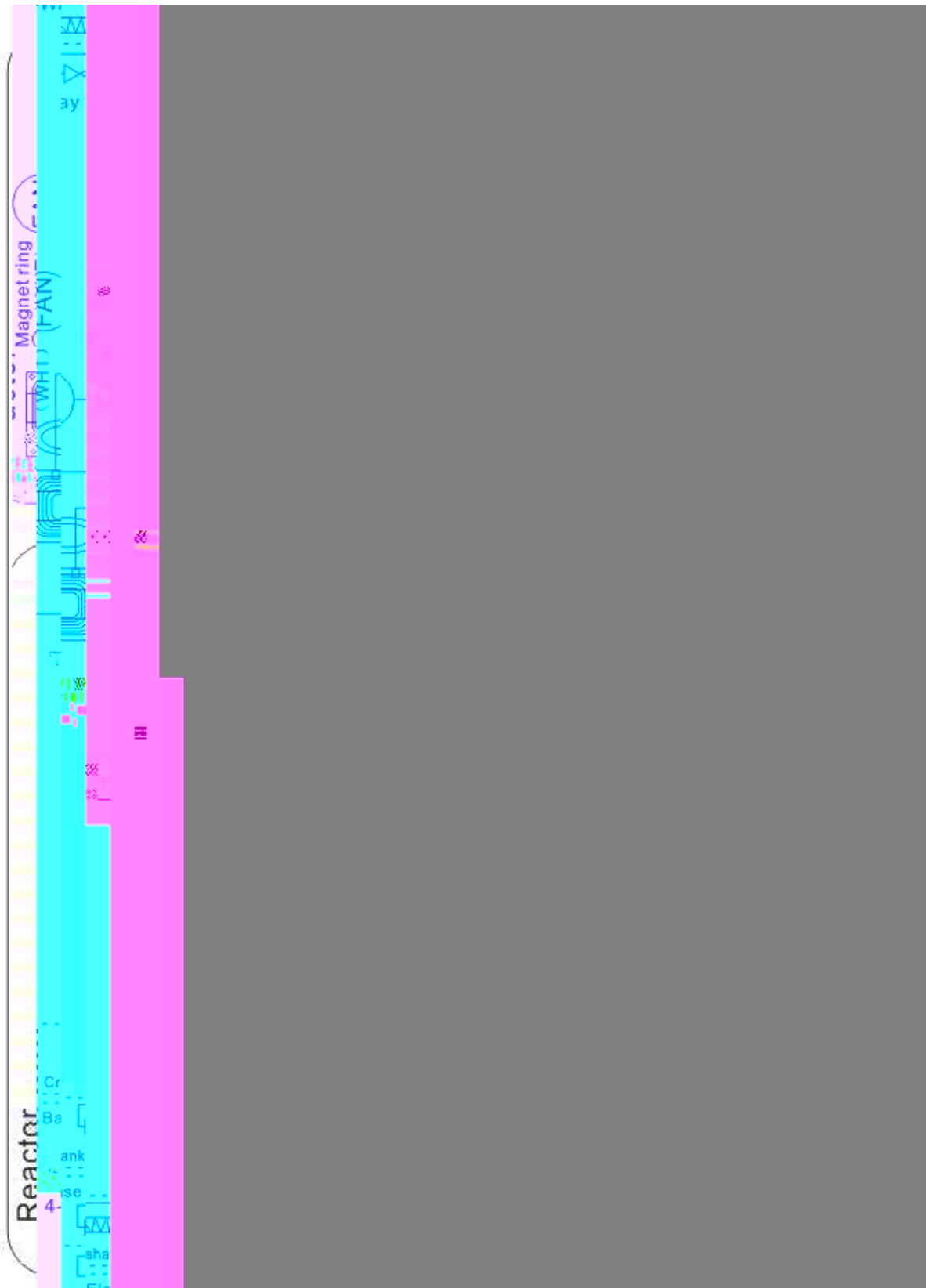

6.3 ZWEMBAD WARMTEPOMP BEDRADING SCHEMA

Réf. 71682/71683

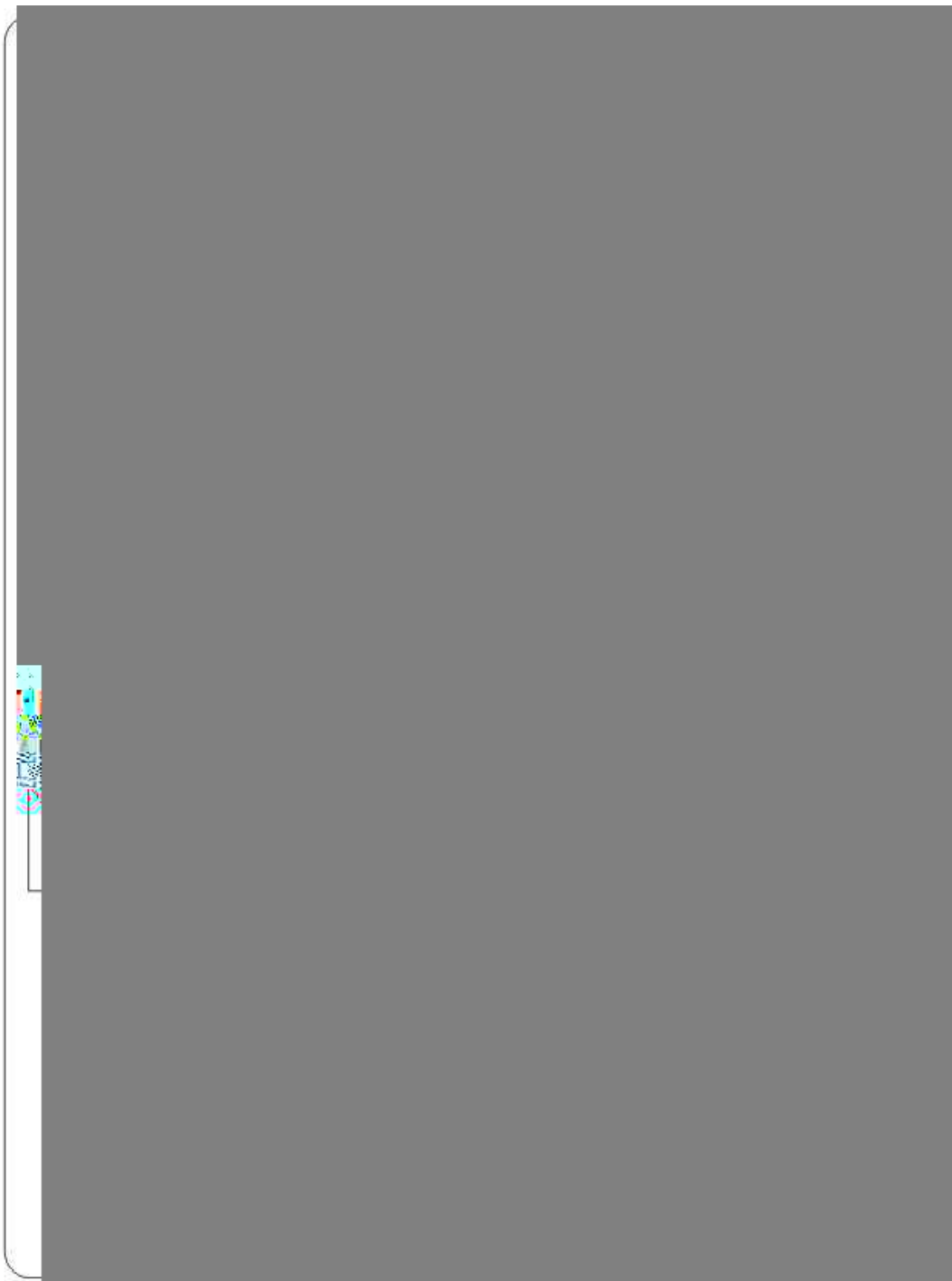

6.4 ZWEMBAD WARMTEPOMP BEDRADING SCHEMA

Ref. 68822 (R410A)

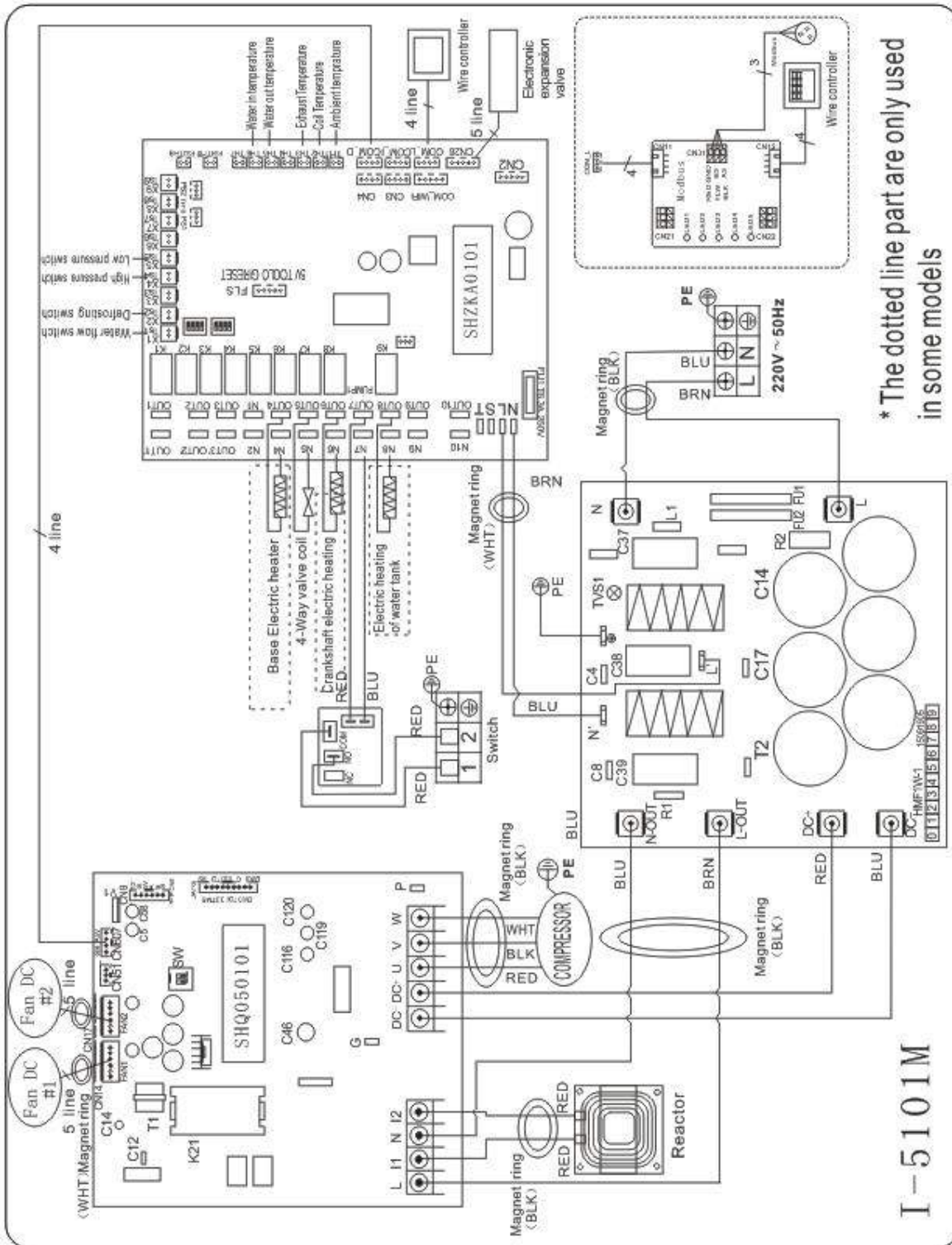

6.5 ZWEMBAD WARMTEPOMP BEDRADING SCHEMA

Ref. 68821/68823 (R410A)

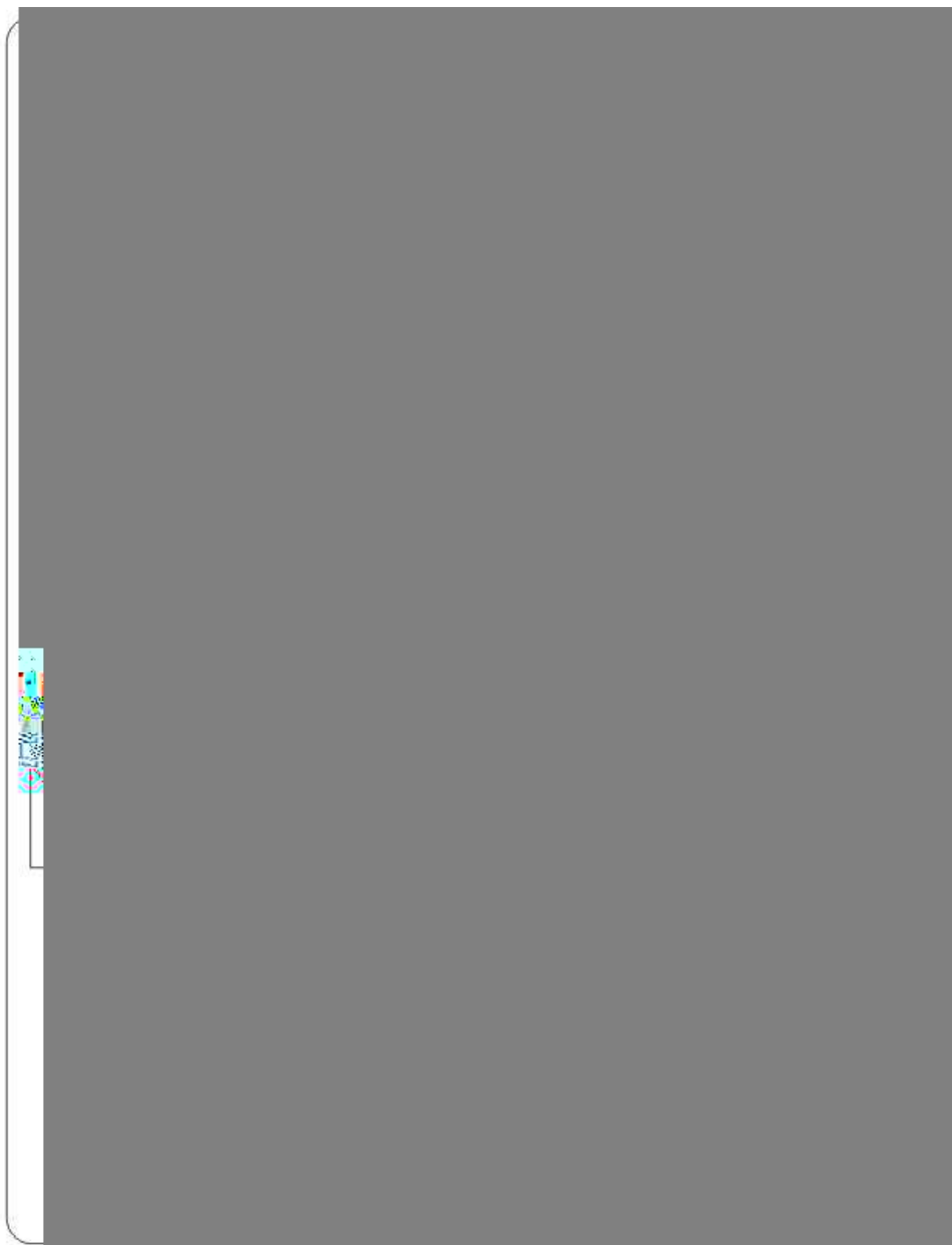

OPMERKING:

(1) Bovenstaande elektrisch bedradings schema is alleen ter referentie, onderwerp alstublieft de machine volgens het bedradingschema.

(2) De zwembad warmtepomp moet ook verbonden worden met een aarding draad, alhoewel de warmtewisselaar van het apparaat elektrisch geïsoleerd is van de rest van het apparaat. Het aarden van het apparaat is nog steeds nodig om u te beschermen tegen kortsluitingen in het apparaat. Verbinding is ook nodig.

Afsluiting: Een afsluiting betekent (circuit onderbreken, gezeekerde of niet-gezeekerde schakelaar) moet geplaatst worden binnen het zicht en of direct bereikbaar vanaf het apparaat. Dit is normaal gebruik op commerciële en residentiële warmtepompen. Het voorkomt het op afstand aan zetten van het apparaat en staat het afsluiten van de stroom van het apparaat toe terwijl het apparaat wordt nagekeken.

6.4 Elektrische aansluiting

De stroomtoevoer voor de warmtepomp moet bij voorkeur afkomstig zijn van een exclusief circuit met regulerende beschermingscomponenten (30mA differentiaalbeveiliging) en een magnetothermische schakelaar.

- De elektrische installatie moet worden uitgevoerd door een gespecialiseerde vakman (elektricien) in overeenstemming met de normen en voorschriften die gelden in het land van installatie.
- Het warmtepomp circuit moet worden aangesloten op een veiligheidscircuit op het klemmenblok.
- De kabels moeten correct zijn geïnstalleerd om interferentie te voorkomen.
- De pomp is bedoeld voor aansluiting op een algemene voeding met een aardaansluiting.
- Sectie van de kabel; Dit gedeelte is indicatief en moet worden gecontroleerd en aangepast aan de behoeften en gebruiksomstandigheden.
- De tolerantie van een acceptabele spanningsvariatie is +/- 10% tijdens bedrijf.

De verbindingen moeten worden gedimensioneerd op basis van de kracht van het apparaat en de staat van installatie.

Modellen	Stroomonderbreker	Maximale lengte van de draad			
		2,5 mm ²	4 mm ²	6 mm ²	10 mm ²
PROELYXP07i	7 A	84 m	135 m	200 m	335 m
PROELYXP09i	9 A	57 m	90 m	130 m	225 m
PROELYXP11i	11A				
PROELYXP14i	14 A	43 m	68 m	100 m	170 m
PROELYXP16i	16 A	34 m	54 m	80 m	135 m
PROELYXP20i	20 A	29 m	45 m	66 m	110 m
PROELYXP26i	26 A	/	25 m	38 m	62 m
PROELYXP30i	35 A	/	/	22 m	36 m
PRO ELYO INVERBOOST NN 26T	9 A	15 m	35 m	49 m	81 m
PRO ELYO INVERBOOST NN 35	34 A	/	/	22 m	36 m
PRO ELYO INVERBOOST NN 35T	13 A	12 m	27 m	39 m	68 m

 **Deze waarden worden als richtlijn gegeven, alleen de tussenkomst van een geautoriseerde technicus kan de waarden bepalen die overeenkomen met uw installatie.**

De elektrische leiding moet zijn voorzien van een aardaansluiting en een stroomonderbreker met een verschil van 30 mA in het hoofd.

6.5 Installatie van de schermbediening

Foto (1)



Foto (2)

Foto (3)



Foto (4)



Foto (5)



- Verwijdering en of plaatsing van het bediening wordt van de connector (foto 1-2)
- Installatie van de geleverde kabel (foto 3-4)
- Om de kabel door te voeren met het doorvoerpakket (foto 4-5) en beiden direct te verbinden

6.6 Installatie van de Modbus/Fluidra Connect-siginaaldraad

Foto(6)



Foto(7)



Foto(8)



Foto(9)

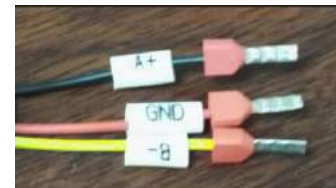

- Open het klepje van de aansluitingen

Droog contact timer-verbinding

Timer

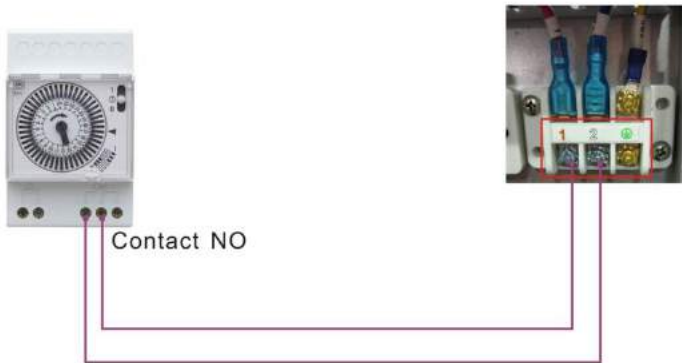

Dry contact pump aansluiting

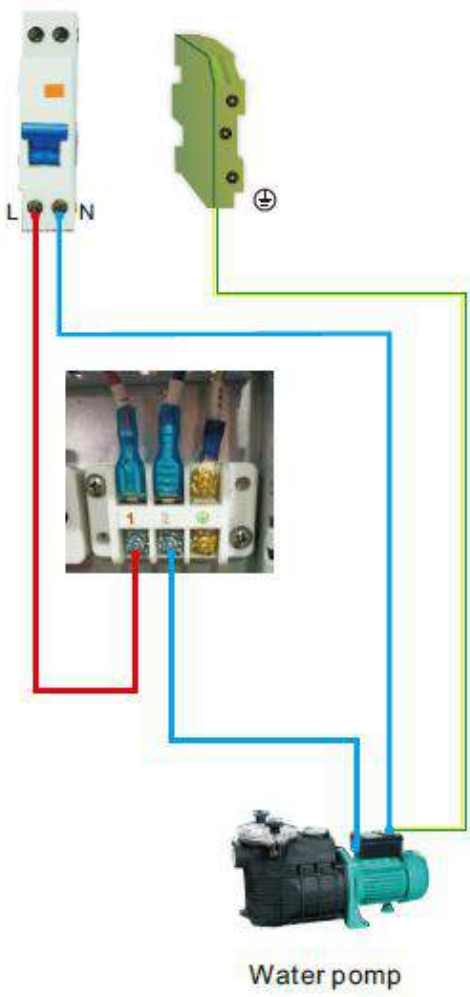

7.1 Functies van het LED bedieningspaneel



Wanneer de warmtepomp op het vermogen wordt aangesloten, geeft het LED-display gedurende 3 seconden een code weer die het warmtepompmodel aangeeft.



7.2 De toetsen en hun activiteiten

7.2.1 -knop

Druk op  om de warmtepomp start, toont het LED-display van de gewenste temperatuur van het water gedurende 5 seconden, toont vervolgens de inlaat temperatuur van het water en van de werking mode.

Druk op  om de warmtepomp te stoppen en te late

Parameter controle:

Druk op  eerst, druk vervolgens op  om de parameter gebruiker controleren van d0 volgens d11

Code	Staat	strekking	Opmerking
d0	IPM vormtemperatuur	0-120°C	Real testen waarde
d1	Inlet water temp.	-9°C ~ 99°C	Real testen waarde
d2	Uitlaat water temp.	-9°C ~ 99°C	Real testen waarde
d3	Ambient temp.	-30°C ~ 70°C	Real testen waarde
d4	Frequency limitation code	0,1,2,4,8,16	Real testing value
d5	Piping temp.	-30°C ~ 70°C	Real testen waarde
d6	uitlaatgastemperatuur	0°C ~ 5°C (125°C)	Real testen waarde
d7	Stap van EEV	0 ~ 99	N*5
d8	Compressor loopt frequentie	0 ~ 99Hz	Real testen waarde
d9	compressor huidige	0 ~ 30A	Real testen waarde
d10	Huidige ventilatorsnelheid	0-1200 (rpm)	Real testen waarde
d11	Error code voor de laatste keer	Alle foutcode	
d12	MODBUS COM	0 - 5	Instelling, alleen Modbus
d13	MODBUS ID Adres	1 - 88	Instelling, alleen Modbus
d14	Productcode	0000- FFFF	Instelling, alleen Modbus

Opmerking: d4: frequentiebeperkingscode,

0: geen frequentielimiet;



1: Coilpijp temperatuurgrens;

2: Frequentiebeperking voor oververhitting of oververhitting;

4: Drive Huidige frequentielimiet;

8: Frequentielimiet aandrijfspanning;







16: Frequentiebeperking voor hoge temperaturen

Druk op  eerst, druk vervolgens op  om te controleren / aanpassen van de parameter gebruiker van P1 tot P7

Code	Naam	strekking	Standaard	Opmerking
P0	Verplichte ontdooiing	0-1	0	0: standaard normale werking 1: verplichte ontdooiing.
P1	Werkmodus	0-1	1	1 Verwarming mode, 0 koelbedrijf
P2	Timer on / off	0-1	0	1 Timer aan / uit onder functie, 0 Timer on / off is van de functie (De instelling van de P5 en P6 zal niet werken)
P3	Waterpomp	0-1	0	1 Altijd lopen, 0 Afhankelijk van het verloop van de compressor
P4	Huidige tijd	HH:MM	0:00	<u>0-23:0-59</u>
P5	Wekker aan	HH:MM	0:00	<u>0-23:0-59</u>
P6	Timer uit	HH:MM	0:00	<u>0-23:0-59</u>
P7	Inlet water temp. correctie	-9~9	0	Standaardinstelling: 0
P12	MOBUS COM	0 - 5	0	Alleen Modbus (Standaardwaarde na reset)
P13	MODBUS ID Adres	1 - 88	9	Alleen Modbus (Standaardwaarde na reset)

Code met verbinding	Parameter P	Omschrijving
71676	17FC	PAC PROELYXP07i 7-3.1Kw
71677	17FD	PAC PROELYXP09i 9-2.3Kw
71678	17FE	PAC PROELYXP11i 11-2.9Kw
71679	17FF	PAC PROELYXP14i 14-3.2Kw
71680	1800	PAC PROELYXP16i 16-3.8Kw
71681	1801	PAC PROELYXP20i 20-4.7Kw
71682	1802	PAC PROELYXP26i 26-5.9Kw
71683	1803	PAC PROELYXP30i 30-6.8Kw
68821	0CD5	PAC PROELYO INVERBOOST NN 26T 26-5.9Kw
68822	0CD6	PAC PROELYO INVERBOOST NN 35 35-8Kw
68823	0CD7	PAC PROELYO INVERBOOST NN 35T 35-8Kw

Productcode parameter P instelling (alleen MODBUS)

Druk gedurende 5 seconden op  + , het eerste digitale nummer knippert, druk op  of  om het doelnummer uit 0-F te kiezen en druk vervolgens op  Go om het tweede nummer aan te passen. Dat geldt ook voor het derde en vierde cijfer. Druk ten slotte op  om de instelling op te slaan en af te sluiten, of deze wordt na 15 seconden automatisch afgesloten.

Na de instelling kon de productcodeparameter P de systeemreset niet resetten. De instelwaarde voor de productcode blijft altijd behouden.



Druk

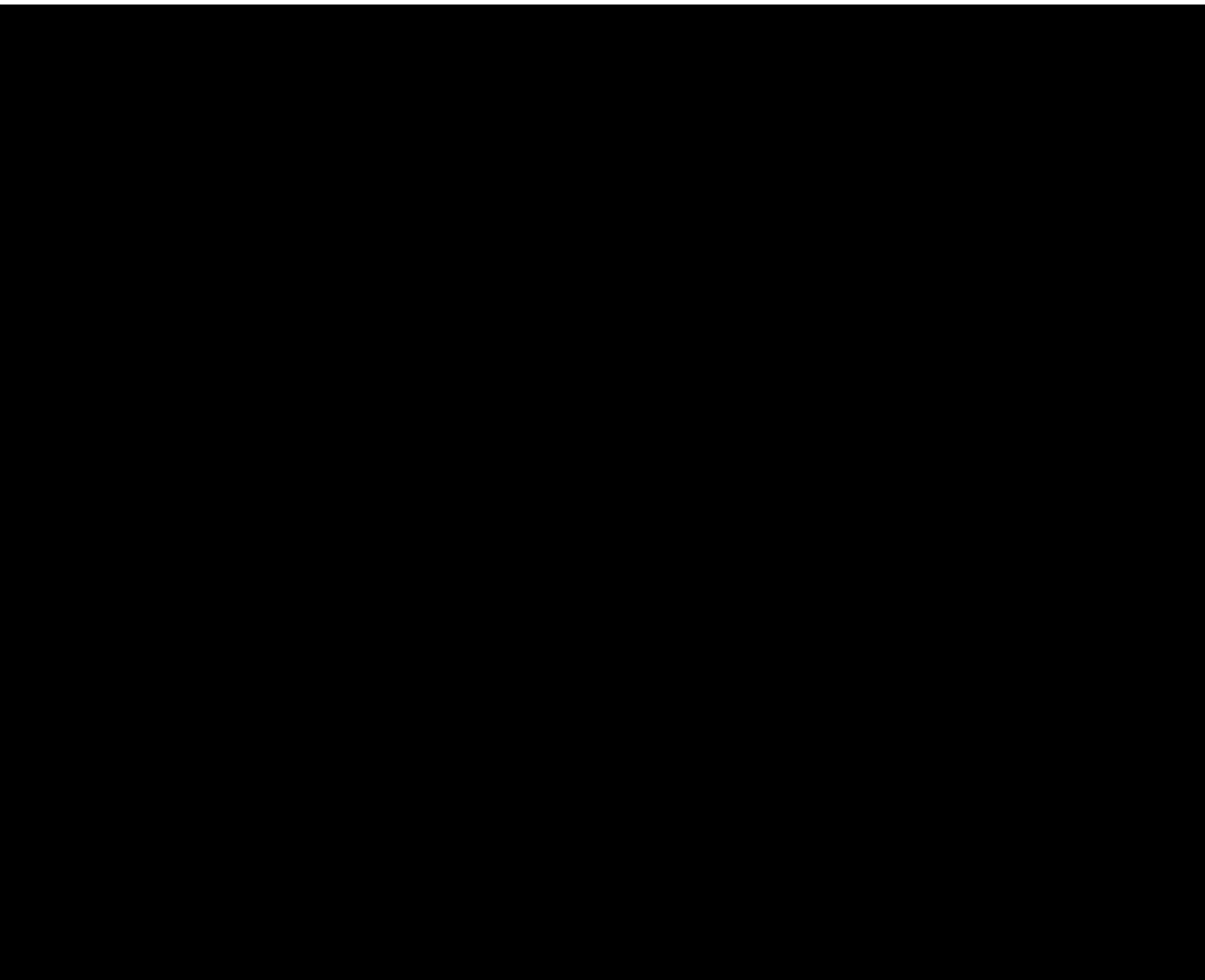

7.2.12 Automatische modus

Er zijn 3 modellen voor het apparaat, alleen verwarming, automatische modus (verwarmings- en koelingschakelaar), alleen koeling.

U kunt de verwarmingsmodus en de automatische modus inschakelen door gedurende 5 seconden op te drukken, ongeacht of het apparaat aan of uit staat.

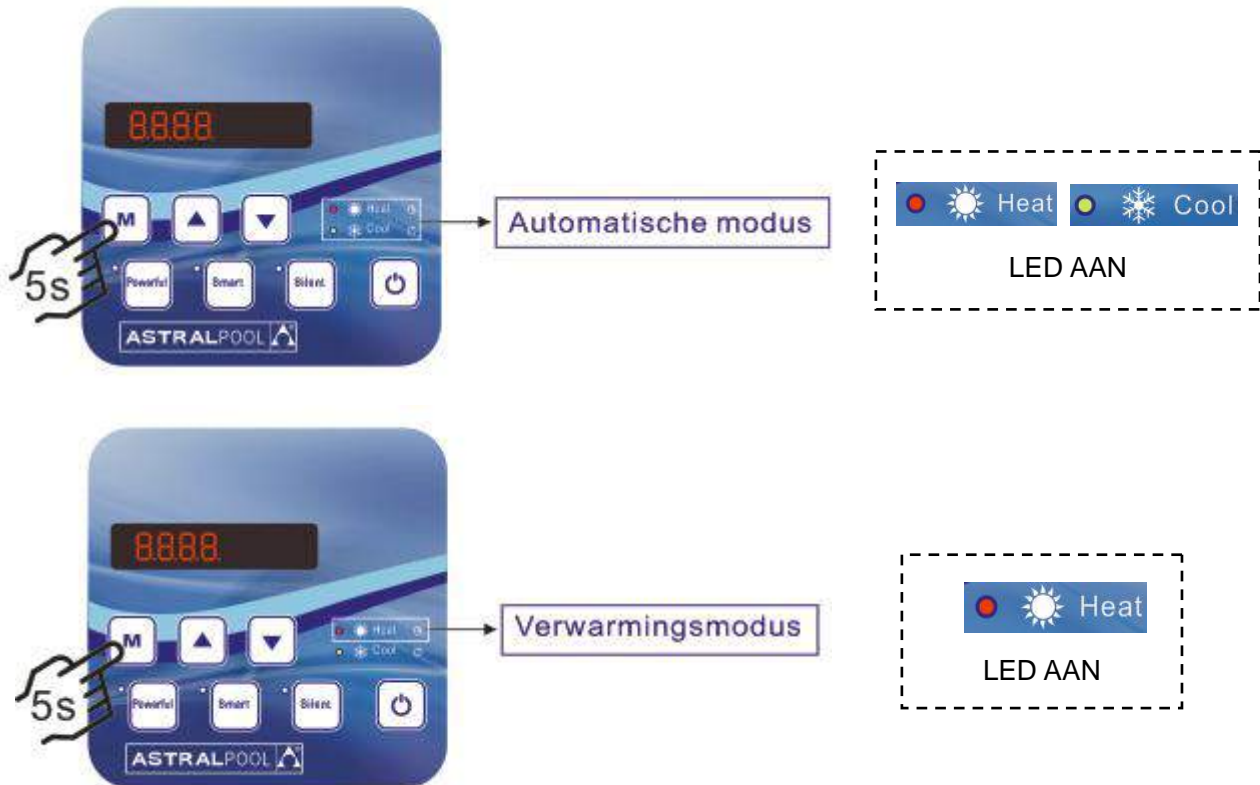

Bedieningslogica van de automatische modus

Optie 1 Waterpomp heeft betrekking op de werking van de warmtepomp om te starten of te stoppen.

De waterpomp start 60 seconden voordat de compressor, de waterpomp begint 30 seconden en detecteert vervolgens de waterstroomschakelaar.

Wanneer de warmtepomp in de stand-bymodus komt, stopt de waterpomp 60 seconden nadat de compressor is gestopt.

De waterpomp wordt opnieuw gestart om gedurende 3 minuten te werken en stopt wanneer de standby-tijd meer dan 2 uur is.

	Staat	Voorbeeld	Waterpomp werkende logica
Verwarmingsmodus	$T1 > T_{set} - 1$, duurt 30 minuten	$T1 > 27^{\circ}\text{C}$, duurt 30 minuten	De waterpomp zal gedurende 2 uur naar de stand-bymodus gaan en zal niet starten, behalve de voeding uitschakelen en opnieuw opstarten. De warmtepomp start 3 minuten nadat de waterpomp de stand-bymodus heeft verlaten om de watertemperatuur te detecteren. T1 opnieuw.
Koelmodus	$T1 < T_{set} + 1$, duurt 30 minuten	$T1 < 29^{\circ}\text{C}$, duurt 30 minuten	De waterpomp zal gedurende 2 uur naar de stand-bymodus gaan en zal niet starten, behalve de voeding uitschakelen en opnieuw opstarten. De warmtepomp start 3 minuten nadat de waterpomp de stand-bymodus heeft verlaten om de watertemperatuur te detecteren. T1 opnieuw.

Optie 1

Wanneer de warmtepomp aan staat (in bedrijf of in stand-by), zal de waterpomp altijd aan staan. Het zal gedurende 1 minuut werken na handmatig uitschakelen.

NOTE :

Tset = Watertemperatuur testen

Bijvoorbeeld : Tset = 28°C Watertemperatuur testen in uw zwembad warmtepomp

Tset-1 = less 1°C dan het testen van de temperatuur

Tset- 1 = $28-1=27^{\circ}\text{C}$

Tset+1= more 1°C dan het testen van de temperatuur

Tset+ 1 = $28+1=29^{\circ}\text{C}$

7.3 Logica voor verwarming

Werk status	Werkmodus	Water op temperatuur-T1	Bijvoorbeeld water op temperatuur-T1	Werkniveau van warmtepomp	
1	Wanneer u de "Smart-werkmodus" selecteert	$T1 < Tset-1$	$T1 < 27^{\circ}C$	Krachtige modus-frequentie F9	
2		$Tset-1 \cong T1 < Tset$	$27^{\circ}C \cong T1 < 28^{\circ}C$	Frequentie: F9 -F8-F7,...,-F2	
3		$Tset \cong T1 < Tset+1$	$28^{\circ}C \cong T1 < 29^{\circ}C$	Stille modus-Frequentie F2	
4		$T1 \cong Tset+1$	$T1 \cong 29^{\circ}C$	HP zal Stand-by zijn, stoppen met werken totdat het water op temperatuur zakt tot minder dan $28^{\circ}C$.	
5	Wanneer u de "Stille werkmodus" selecteert.	$T1 < Tset$	$T1 < 28^{\circ}C$	Smart-modus -Frequentie F5.	
6		$Tset \cong T1 < Tset+1$	$28^{\circ}C \cong T1 < 29^{\circ}C$	Stille modus-Frequentie F2/F1.	
7		$T1 \cong Tset+1$	$T1 \cong 29^{\circ}C$	HP zal Stand-by zijn, stoppen met werken totdat het water op temperatuur zakt tot minder dan $28^{\circ}C$.	
8	Wanneer u de "Krachtige werkmodus" selecteert.	$T1 < Tset+1$	$T1 < 29^{\circ}C$	Krachtige modus-frequentie F10/F9	
9		$T1 \cong Tset+1$	$T1 \cong 29^{\circ}C$	HP zal Stand-by zijn, stoppen met werken totdat het water op temperatuur zakt tot minder dan $28^{\circ}C$.	
10	Start opnieuw met het verwarmen van water in de standby-status	$T1 \cong Tset$	$T1 \cong 28^{\circ}C$	Standby	
11		Wanneer HP werkt in de "Smart-modus"	$Tset > T1 \cong Tset-1$	$28^{\circ}C > T1 \cong 27^{\circ}C$	Stille modus-Frequentie F2
12			$Tset-1 > T1 \cong Tset-2$	$27^{\circ}C > T1 \cong 26^{\circ}C$	Frequentie: F2 -F3-F4,...,-F9
13			$< Tset-2$	$< 26^{\circ}C$	Krachtige modus-frequentie F9
14	Wanneer HP werkt in de "Stille modus"	$\cong Tset$	$\cong 28^{\circ}C$	Standby	
15		$Tset > T1 \cong Tset-1$	$28^{\circ}C > T1 \cong 27^{\circ}C$	Stille modus-Frequentie F2/F1	
16		$T1 < Tset-1$	$T1 < 27^{\circ}C$	Smart modus -frequency F5	
17	Wanneer HP werkt in de "Krachtige modus"	$T1 < Tset-1$	$T1 < 27^{\circ}C$	Krachtige modus-frequentie F10/F9	

7.4 Logica voor verwarming

Werk status		Werkmodus	Water op temperatuur-T1	Bijvoorbeeld water op temperatuur-T1	Werkniveau van warmtepomp
1	Opstarten van warmtepomp	Wanneer u de	$T1 \cong Tset-1$	$T1 \cong 27^{\circ}C$	Standby.
2		"Smart-werkmodus" selecteert	$Tset-1 < T1 \cong Tset$	$27^{\circ}C < T1 \cong 28^{\circ}C$	Stille modus-Frequentie F2
3			$Tset < T1 \cong Tset+1$	$28 < T1 \cong 29^{\circ}C$	Frequentie: F9 -F8-F7,...,- F2
4			$T1 \cong Tset+1$	$T1 \cong 29^{\circ}C$	Krachtige modus-F9
5		Wanneer u de	$T1 \cong Tset-1$	$\cong 27^{\circ}C$	Standby
6		"Stille werkmodus" selecteert.	$Tset-1 < T1 \cong Tset$	$27^{\circ}C < T1 \cong 28^{\circ}C$	Stille modus-Frequentie F2/F1
7			$T1 > Tset$	$T1 > 28^{\circ}C$	Smart modus -frequency F5
8		Wanneer u de "Krachtige werkmodus" selecteert.	$T1 > Tset-1$	$T1 > 27^{\circ}C$	Krachtige modus-frequentie F10/F9
9			$T1 \cong Tset-1$	$T1 \cong 27^{\circ}C$	Standby
10	Start opnieuw met het verwarmen van water in de standby-status	Smart	$T1 \cong Tset-1$	$T1 \cong 27^{\circ}C$	Standby
11			$Tset \cong T1 < Tset+1$	$28 \cong T1 < 29^{\circ}C$	Stille modus-Frequentie F2
12			$Tset+1 \cong T1 < Tset+2$	$29 \cong T1 < 30^{\circ}C$	Krachtige modus: F2 -F3-F4,...,- F9
13			$T1 \cong Tset+2$	$T1 \cong 30^{\circ}C$	Krachtige modus-frequentie F9
14		Silent	$Tset < T1 \cong Tset+1$	$28 < T1 \cong 29^{\circ}C$	Stille modus-Frequentie F2/F1
15			$T1 > Tset+1$	$T1 > 29^{\circ}C$	Smart modus -frequency F5
16		Powerful	$T1 > Tset+1$	$T1 > 29^{\circ}C$	Krachtige modus-frequentie F10/F9
17	$T1 \cong Tset-1$		$T1 \cong 27^{\circ}C$	Standby	

8. Problemen

8.1 Fout code scherm op LED draad bediening

Storing	Foutcode	Reden	Oplossing
Fout in inlaatwatertemperatuur sensor T1-TH6	PP01	<ol style="list-style-type: none"> 1. De sensor in open of kortsluiting 2. De bedrading van de sensor zit los 	<ol style="list-style-type: none"> 1. Controleer of verander de sensor 2. Herbevestig de bedrading van de sensoren
Uitlaat watertemperatuur sensor defect T2-TH5	PP02	<ol style="list-style-type: none"> 1. De sensor in open of kortsluiting 2. De bedrading van de sensor zit los 	<ol style="list-style-type: none"> 1. Controleer of verander de sensor 2. Re-fix de bedrading van de sensoren
Storing verwarmingslans sensor T3-TH2	PP03	<ol style="list-style-type: none"> 1. De sensor in open of kortsluiting 2. De bedrading van de sensor zit los 	<ol style="list-style-type: none"> 1. Controleer of verander de sensor 2. Re-fix de bedrading van de sensoren
Gasterugvoer sensor defect	PP04	<ol style="list-style-type: none"> 1. De sensor in open of kortsluiting 2. De bedrading van de sensor zit los 	<ol style="list-style-type: none"> 1. Controleer of verander de sensor 2. Re-fix de bedrading van de sensoren
Uitval van de omgevingstemperatuur sensor T5-TH1	PP05	<ol style="list-style-type: none"> 1. De sensor in open of kortsluiting 2. De bedrading van de sensor zit los 	<ol style="list-style-type: none"> 1. Controleer of verander de sensor 2. Re-fix de bedrading van de sensoren
Uitlaatpijpsensor defect T6-TH3	PP06	<ol style="list-style-type: none"> 1. De sensor in open of kortsluiting 2. De bedrading van de sensor zit los 	<ol style="list-style-type: none"> 1. Controleer of verander de sensor 2. Re-fix de bedrading van de sensoren
Vorstbescherming in de winter	PP07	De omgevingstemperatuur of de waterinlaattemperatuur is te laag	Normale bescherming
Lage omgevingstemperatuur beveiliging	PP08	<ol style="list-style-type: none"> 1. Let de reikwijdte van het gebruik milieu 2. Sensorafwijking 	<ol style="list-style-type: none"> 1. Stop met behulp van, buiten het gebruik van 2. Wijzig de sensor
Leiding temperatuur te hoge bescherming onder koelmodus T3-TH2	PP10	<ol style="list-style-type: none"> 1. De omgevingstemperatuur is te hoog of de watertemperatuur is te hoog in de koelmodus 2. Koelsysteem is abnormaal 	<ol style="list-style-type: none"> 1. Controleer de reikwijdte van het gebruik 2. Controleer het koelsysteem
T2-TH5 watertemp. Te lage bescherming in de koelmodus	PP11	<ol style="list-style-type: none"> 1. Lage waterstroom 2. T2-TH5-temperatuursensor abnormaal 	<ol style="list-style-type: none"> 1. Controleer de waterpomp en het vaarwegsysteem 2. Verander de T2-TH5-temperatuur sensor

Storing	Foutcode	Reden	Oplossing
Hoge drukfout TS4	EE01	<ol style="list-style-type: none"> 1. De temperatuur van de omgeving is te hoog 2. Watertemperatuur is te hoog 3. Waterstroom is te laag Het ventilatortoerental is abnormaal of de ventilatormotor is beschadigd	<ol style="list-style-type: none"> 1. Controleer de waterstroom of waterpomp 2. Controleer de ventilatormotor 3. Controleer en repareer het leidingsysteem
Lagedrukstoring TS5	EE02	<ol style="list-style-type: none"> 1. EEV is geblokkeerd of het leidingsysteem is vastgelopen 2. Motortoerental is abnormaal of motor is beschadigd 3. Gaslekage 	<ol style="list-style-type: none"> 1. Controleer de EEV en het leidingsysteem Controleer de motor 2. Door de hoge drukmeter om de drukwaarde te controleren
Uitval waterstroom TS1	EE03 Or" ON"	<ol style="list-style-type: none"> 1. Waterstroomschakelaar is beschadigd 2. Geen / Onvoldoende waterstroom. 	<ol style="list-style-type: none"> 1. Wijzig de waterstromingsschakelaar 2. Controleer de waterpomp of het vaarwegsysteem
Oververhittingsbeveiliging voor watertemperatuur (T2-TH5) in verwarmingsmodus	EE04	<ol style="list-style-type: none"> 1. Lage waterstroom 2. Waterstroomschakelaar zit vast en de watertoevoer is afgesneden 3. T2-TH5-sensor is abnormaal 	<ol style="list-style-type: none"> 1. Controleer het watersysteem 2. Controleer de waterpomp of waterstroomschakelaar 3. Controleer sensor T2-TH5 of wijzig een andere sensor
T6-TH3 Uitlaat te hoge bescherming	EE05	<ol style="list-style-type: none"> 1. Geen gas 2. Lage waterstroom 3. Het systeem is geblokkeerd 4. Uitlaat temp. Sensorfout 	<ol style="list-style-type: none"> 1. Controleer de hogedrukmeter, vul deze bij te laag gas bij 2. Controleer het vaarwegsysteem en de waterpomp 3. Controleer het leidingsysteem als er een blok was 4. Wijzig een nieuwe uitlaattemp. sensor
Controller mislukt	EE06	<ol style="list-style-type: none"> 1. De draadverbinding is niet goed of beschadigde signaaldraad 2. Controllerstoring 	<ol style="list-style-type: none"> 1. Controleer en sluit de signaaldraad opnieuw aan 2. Verander een nieuwe signaaldraad 3. Schakel de stroomtoevoer uit en start de machine opnieuw op 4. Verander een nieuwe controller

Storing	Foutcode	Reden	Oplossing
Compressor huidige bescherming	EE07	<ol style="list-style-type: none"> 1. De stroom van de compressor is onmiddellijk te groot 2. Verkeerde aansluiting voor compressor-fasevolgorde 3. Compressorophoping van vloeistof en olie leiden tot de stroom wordt groter 4. Compressor of driverboard beschadigd 5. De waterstroom is abnormaal 6. Krachtfluctuaties binnen een korte tijd 	<ol style="list-style-type: none"> 1. Controleer de compressor 2. Controleer het vaarwegsysteem 3. Controleer of het vermogen binnen het normale bereik valt 4. Controleer de aansluiting van de fasevolgorde
Communicatiefout tussen controller en moederbord	EE08	<ol style="list-style-type: none"> 1. Slechte signaaldraadverbinding of beschadigde signaaldraad 2. Controllerstoring 	<ol style="list-style-type: none"> 1. Controleer en sluit de signaaldraad opnieuw aan 2. Verander een nieuwe signaaldraad 3. Schakel de stroomtoevoer uit en start de machine opnieuw op 4. Verander een nieuwe controller
Communicatiefout tussen hoofdbesturingskaart en rijbord	EE09	<ol style="list-style-type: none"> 1. Slechte verbinding van communicatiedraad 2. De draad is beschadigd 	<ol style="list-style-type: none"> 1. Controleer de draadverbinding 2. Verander een nieuwe draad
VDC-voltage te hoge beveiliging	EE10	<ol style="list-style-type: none"> 1. Moeder lijnspanning is te hoog 2. Driver board is beschadigd. 	<ol style="list-style-type: none"> 1. Controleer of het vermogen binnen het normale bereik valt 2. Wijzig driverbord of hoofdbord
IPM-modulebeveiliging	EE11	<ol style="list-style-type: none"> 1. Gegevensfout 2. Wrong compressor-fase verbinding 3. Compressor vloeistof en olie accumulatie leiden tot de stroom wordt groter 4. Compressor of driverboard beschadigd 	<ol style="list-style-type: none"> 1. Programmafout, elektriciteit uitschakelen en herstarten na 3 minuten 2. Stuurbord wijzigen 3. Controleer de aansluiting van de compressorsequentie
VDC-voltage te lage beveiliging	EE12	<ol style="list-style-type: none"> 1. Moeder lijnspanning is te laag 2. Driver board is beschadigd. 	<ol style="list-style-type: none"> 1. Controleer of het vermogen binnen het normale bereik valt 2. Wijzig bestuurdersbord
Voer stroom in via een hoge beveiliging	EE13	<ol style="list-style-type: none"> 1. De compressorstroom is te groot kortstondig 2. De waterstroom is abnormaal 3. Power schommelingen binnen een korte tijd 4. Verkeerde PFC-inductor 	<ol style="list-style-type: none"> 1. Controleer de compressor 2. Controleer het vaarwegsysteem 3. Controleer of het vermogen binnen het normale bereik valt 4. Controleer of de juiste PFC-inductor wordt gebruikt

Storing	Foutcode	Reden	Oplossing
Het thermische circuit van de IPM-module is abnormaal	EE14	1. Uitgangsfwijking van het thermische circuit van de IPM-module 2. Fan motor is abnormaal of beschadigd Ventilatorblad is gebroken	

Storing	Foutcode	Reden	Oplossing
Uitzondering voor softwarebesturing	EE21	1. Compressor werkt niet 2. Verkeerd programma 3. Onzuiverheid in de compressor veroorzaakt de onstabiele rotatiesnelheid	1. Controleer het moederbord of verander een nieuw board 2. Voer het juiste programma in
Stroomdetectiekringfout	EE22	1. Spanningssignaal abnormaal 2. Driver board is beschadigd	1. Controleer het moederbord of verander een nieuw board 2. Wijzig een nieuwe driverkaart
Compressorstartfout	EE23	1. Hoofdbord is beschadigd 2. Compressor bedradingsfout of slecht contact of niet verbonden 3. Vloeistofophoping binnen 4. Verkeerde fase verbinding voor compressor	1. Controleer het moederbord of verander een nieuw board 2. Controleer de bedrading van de compressor volgens het schakelschema Controleer de compressor of wijzig een nieuwe
Apparaatstoring in omgevingstemperatuur op stuurkaart	EE24	Apparaatstoring bij omgevingstemperatuur	Wijzig driverbord of hoofdbord
Defect compressorfase	EE25	Compressoren U, V, W zijn verbonden met één fase of twee fasen.	Controleer de feitelijke bedrading volgens het schakelschema
Fout bij omschakeling van vierwegklep	EE26	1. Terugslagfout van vierwegklep 2. Gebrek aan koelmiddel (geen detectie wanneer T3-TH2 of T5-TH1 defect is)	1. Schakelen naar koelmodus om de 4-wegklep te controleren als deze op de juiste manier is omgedraaid 2. Wijzig een nieuwe 4-wegklep 3. Vul met gas
EEPROM-gegevens lezen storing	EE27	1. Wrong EEPROM-gegevens in het programma of mislukte invoer van EEPROM-gegevens 2. Fout met moederbord	1. Voer de juiste EEPROM-gegevens opnieuw in 2. Wijzig een nieuw hoofdbord
De inter-chip communicatiefout op de hoofdbesturingskaart	EE28	Hoofdbordfout	1. Schakel de stroomtoevoer uit en start deze opnieuw op 2. Wijzig een nieuw hoofdbord

8.2 Andere fouten en oplossingen (Geen verschijning op LED draad controller)

Storingen	Observering	Redenen	Oplossing
Warmtepomp werkt niet	LED draadcontroller geen verschijning.	Geen stroomvoorziening	Check cable and circuit breaker if it is connected
	LED draad controller toont de actuele tijd.	Warmtepomp in stand-by status	Startup heat pump to run.
	LED draad controller toont de actuele watertemperatuur.	<ol style="list-style-type: none"> 1. Watertemperatuur bereikte ingestelde waarde, HP onder constante temperatuur status. 2. Warmtepomp begint net te lopen. 3. Onder ontdooien. 	<ol style="list-style-type: none"> 1. Controleer watertemperatuur instelling. 2. Start warmtepomp na een paar minuten. 3. LED draadcontroller moet vertonen "ontdooien".
Watertemperatuur koelt wanneer HP loopt onder verwarming's mode	LED draad controller vertoont actuele watertemperatuur en er verschijnt geen fout code.	<ol style="list-style-type: none"> 1. Verkeerde modus geselecteerd. 2. Cijfers tonen tekortkomingen. 3. Controller defect. 	<ol style="list-style-type: none"> 1. Stel de goede modus in 2. Vervang de defecte LED draad controller, en controleer dan de status na het veranderen van de werkende modus, controleer de water inlaat en uitlaatemperatuur. 3. Vervangen of repareer het warmtepomp apparaat
Korte looptijd	LED toont actuele watertemperatuur, er verschijnt geen fout code.	<ol style="list-style-type: none"> 1. Ventilator draait NIET. 2. Luchtventilator hij is niet genoeg. 3. Niet genoeg koelmiddel. 	<ol style="list-style-type: none"> 1. Controleer de kabelverbindingen tussen de motor en ventilator, wanneer nodig, moet het vervangen worden. 2. Controleerlocatie van het warmtepomp apparaat, en elimineer alle obstakels om een goede luchtventilatie mogelijk te maken. 3 Vervang of repareer het warmtepomp apparaat.
Watervlekken	Watervlekken op warmtepomp apparaat.	<ol style="list-style-type: none"> 1. Betonneren. 2. Water lekkage. 	<ol style="list-style-type: none"> 1. Geen actie. 2. Controleer de titanium warmtewisselaar zorgvuldig of het defect is.
Te veel ijs op de verdamper	Te veel ijs op de verdamper.		<ol style="list-style-type: none"> 1. Controleer de locatie van het warmtepomp apparaat, en elimineer alle obstakels om een goede lucht ventilatie mogelijk te maken. 2. Vervang of repareer het warmtepomp apparaat.

Opmerkingen:

1. In de verwarmingsmodus, als de wateruittredetemperatuur hoger is dan de ingestelde temperatuur boven 7 °C, geeft de LED-controller EE04 weer voor bescherming tegen oververhitting van het water.

2. In de koelmodus, als de water-uittemperatuur lager is dan de ingestelde temperatuur boven 7 °C, geeft LED-controller PP11 weer voor bescherming tegen overkoeling van water.

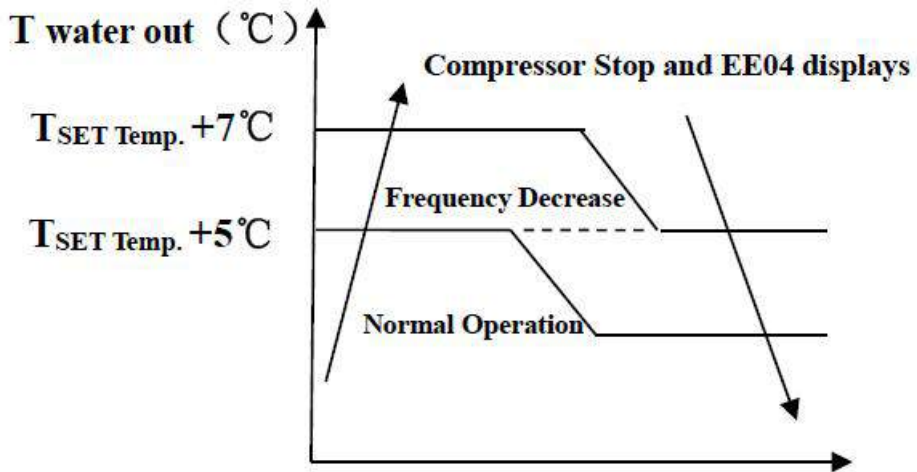

EE04 Bescherming tegen oververhitting van water

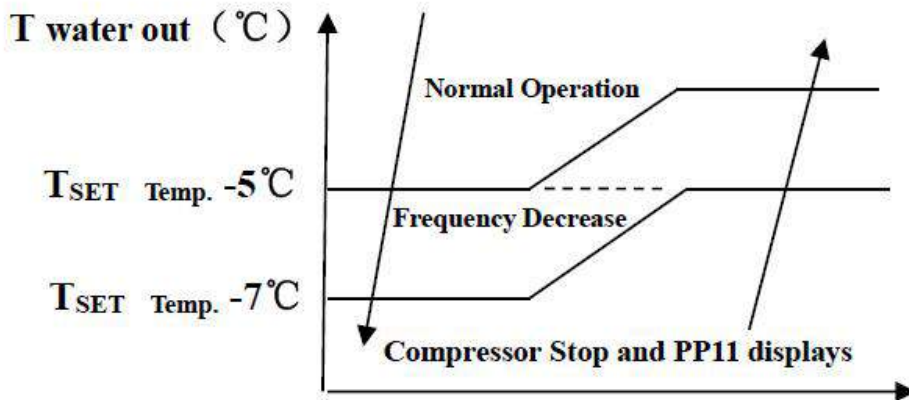

PP11 Bescherming tegen overcooling van water

For example as below:

Mode	Water uit temperatuur	Temperatuur instellen	Staat	Storing
Verwarmingsmodus	36°C	29°C	$T_{out} - T_{set} \geq 7^{\circ}\text{C}$	EE04 Oververhittingsbeveiliging voor watertemperatuur(T2)
Koelmodus	23°C	30°C	$T_{set} - T_{out} \geq 7^{\circ}\text{C}$	PP11 Te lage bescherming voor watertemperatuur(T2)

9.1 Opendeklapt diagram

Model: 71676

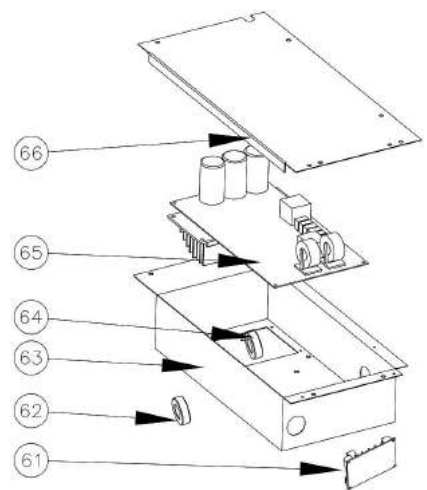
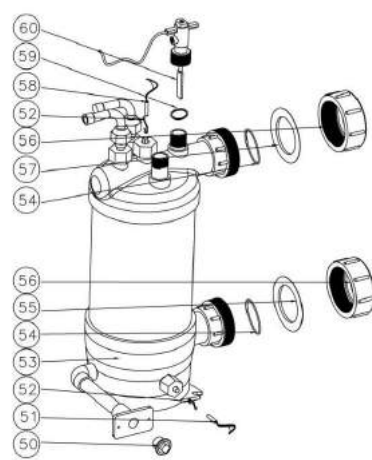
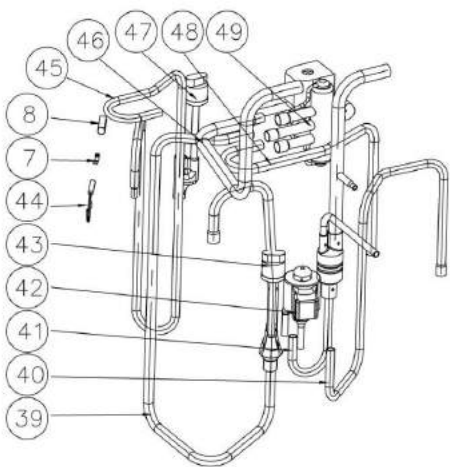
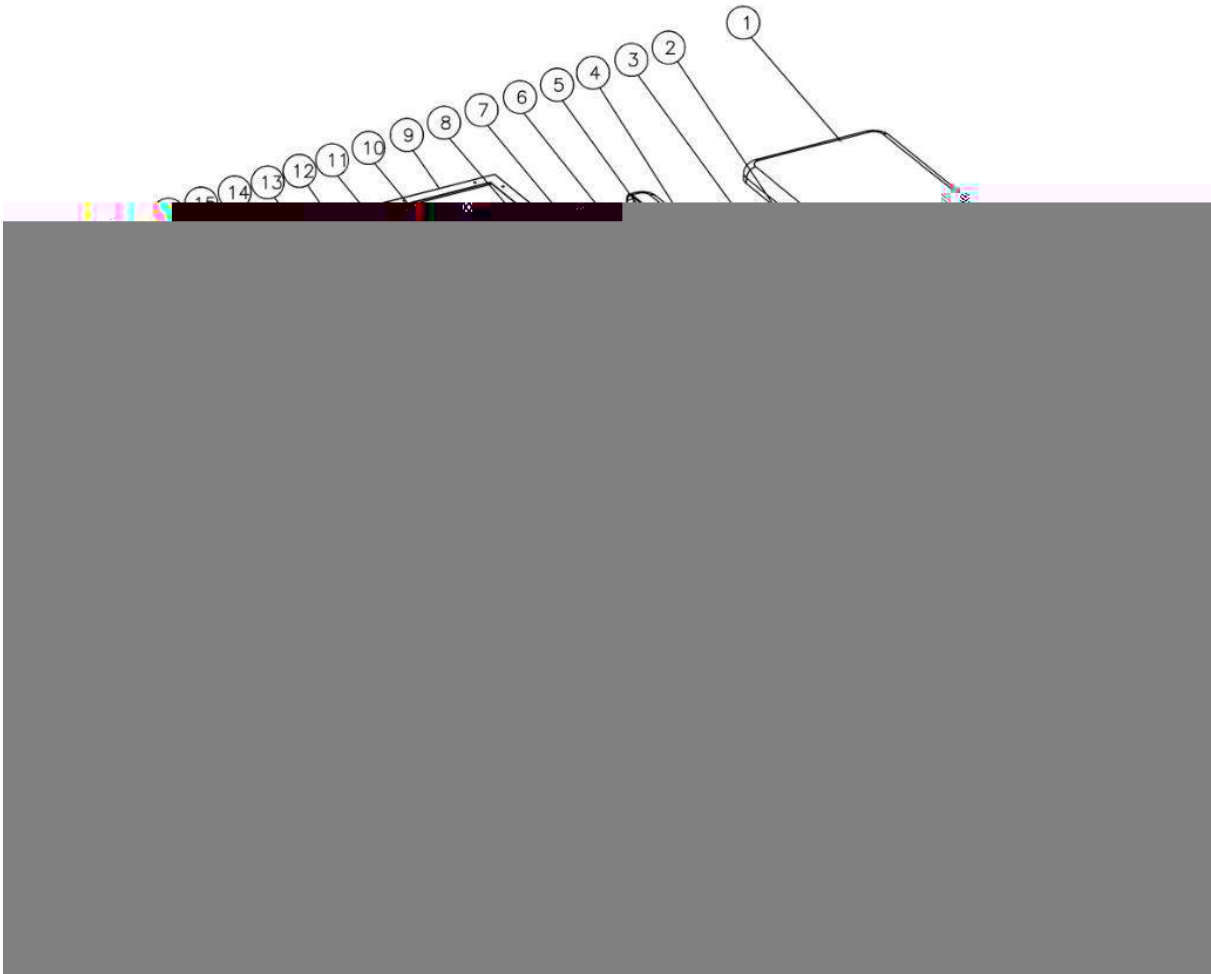

9.2 Onderdelen lijst

Model : 71676

NO	ERP	Naam van de onderdelen	NO	ERP	Naam van de onderdelen
1	1330900291	Bovenklep	34	117020180	Controleur
2	117110020	Omgevingstemp. sensor T5-TH1	35	103000227	Collectieve leidingen
3	133020010	Omgevingstemp. sensor clip	36	136020018	Rubber
4	1330900271	Achterpaneel	37	103000227	Leidingen voor distributie
5	103000227	Verdamper	38	106000011	Manometer
6	117110004	Pijp temp. Sensor T3-TH2	39	113020320	Gas retourleidingen
7	113190001	Sensorhuispijp	40	113080074	Eev naar distributieleidingen
8	113190001	Klem	41	113070042	Uitwisselaar van eev
9	108110038	Bovenframe	42	119000017	Eev
10	108050073	Isolatiepaneel	43	116000071	Lagedrukschakelaar
11	108110043	Ventilatormotorbeugel	44	117110021	Uitlaat temp. Sensor T6-TH3
12	142000058	Verdamper verwarmingsriem	45	113010229	Uitlaat
13	108480015	Riem fixer	46	113030081	4-wegklep naar wisselaar
14	108110004	Pijler	47	116000066	Hogedrukschakelaar
15	112000031	Ventilatormotor	48	113060123	Gasbuis
16	1330900261	Linkerkant paneel	49	121000006	4-weg klep
17	132000015	Waaierblad	50	150000110	Drainage plug
18	1330900251	Voorpaneel	51	117110012	Water in temp. sensor T1-TH6
19	108010014	Grill aan de voorkant	52	108010025	Wisselaar sensor temperatuursensor
20	117230003	Reactor	53	102040705	Titanium warmtewisselaar
21	101000187	Demping voeten van de compressor	54	133020026	Rubberring op wateraansluiting
22	142000072	Compressor verwarmingsriem	55	133020011	Blauwe rubberen ring
23	101000187	Compressor	56	113900082	Wateraansluitsets
24	113100008	Koppelgereedschap	57	133020011	Rode rubberen ring
25	120000091	Globe-klep	58	117110011	Water uit temp. Sensor T2-TH5
26	180140064	Basislade	59	116000001	Afdichtring
27	108010065	Eindplank	60	112100021-1	Waterstroomschakelaar
28	115000004	5-zits terminal	61	117010095	Modbus-modules
29	113100009	Klem	62	117240002	Magneetring
30	1330900281	Rechter paneel	63	108110057	Elektrische doos
31	1332500051	Klemmenblokken plastic kap	64	117240003	Magneetring
32	108010018	Bedradingsdoos	65	117100046	PCB
33	113712007	Waterdichte controllerkast	66	108050017	Elektrische deksel

Model: 71677/71678/71679

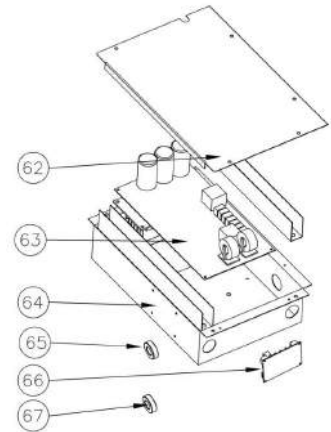
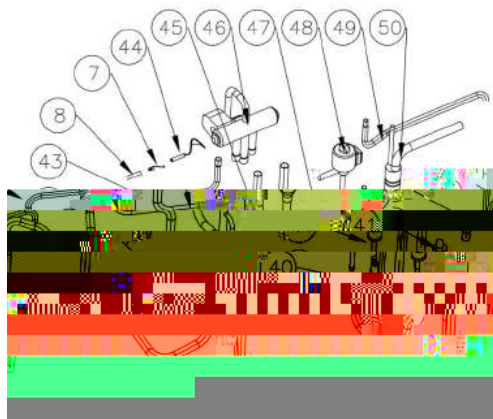
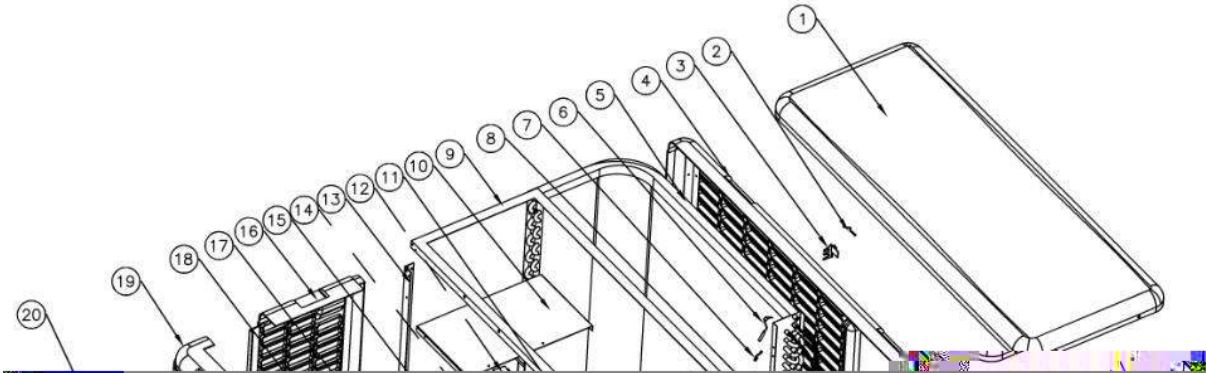

Model: 71677

NO	ERP	Naam van de onderdelen	NO	ERP	Naam van de onderdelen
1	1330900291	Bovenklep	35	113712007	Waterdichte controllerkast
2	117110020	Omgevingstemp. sensor T5-TH1	36	117020180	Controleur
3	133020010	Omgevingstemp. sensor clip	37	103000221	Collectieve leidingen
4	1330900271	Achterpaneel	38	136020005	Rubber blok
5	103000221	Verdamper	39	103000221	Leidingen voor distributie
6	117110004	Pijp temp. sensor T3-TH2	40	113030086	4-weg klep naar wisselaar
7	113100009	Klem	41	116000066	Hogedrukschakelaar
8	113100009	Sensorhuispijp	42	116000071	Lagedrukschakelaar
9	108110038	Bovenframe	43	113010210	Uitlaat
10	108110043	Ventilatormotorbeugel	44	117110021	Uitlaat temp. sensor T6-TH3
11	117230003	Reactor	45	113020322	Gas retourleidingen
12	108480015	Riemklem	46	121000006	4-weg klep
13	108110004	Pijler	47	113060084	4-wegsklep naar collectieve leidingen
14	142000079	Verdamper verwarmingsriem	48	119000017	EEV
15	112000031	Ventilatormotor	49	113080054	EEV naar distributieleidingen
16	1330900261	Linkerkant paneel	50	113070044	Uitwisselaar van EEV
17	108010024	DC-motorafdekking	51	113900082	Wateraansluitsets
18	132000015	Waaierblad	52	112100021-1	Waterstroomschakelaar
19	1330900251	Voorpaneel	53	133020012	Rode rubberen ring
20	108010014	Grill aan de voorkant	54	133020026	Ruberring op wateraansluiting
21	108050073	Isolatiepaneel	55	136020083	Afsluitring
22	113100008	Koperen buis	56	117110011	Water uit temp. sensor T2-TH5
23	120000091	Globe-klep	57	108010025	Wisselaar sensor temperatuursensor
24	142000074	Compressor Verwarming riem	58	102040748	Titanium warmtewisselaar
25	101000188	Demping voeten van de	59	133020011	Blauwe rubberen ring
26	101000188	Compressor	60	117110012	Water in temp. sensor T1-TH6
27	108110066	Basislade	61	150000110	Drainage plug
28	108010065	Vertrekhal bord	62	108050017	Elektrische deksel
29	133090028	Rechter paneel	63	117100046	PCB
30	106000011	Druk meter	64	108110031	Elektrische doos
31	136010004	Klem	65	117240002	Magneetring
32	115000004	5-zits terminal	66	117010095	Modbus-module
33	1332500051	Klemmenblokken plastic kap	67	117240003	Magneetring
34	133030011	Bedradingsdoos			

Model: 71678

NO	ERP	Naam van de onderdelen	NO	ERP	Naam van de onderdelen
1	1330900291	Bovenklep	35	113712007	Waterdichte controllerkast
2	117110020	Omgevingstemp. Sensor T5-TH1	36	117020180	Controleur
3	133020010	Omgevingstemp. Sensor clip	37	103000182	Collectieve leidingen
4	1330900271	Achterpaneel	38	136020005	B-vorm rubber
5	103000182	Verdamper	39	103000182	Leidingen distributie
6	117110004	Pijp temp. sensor T3-TH2	40	113030086	4-wegklep naar wisselaar
7	113100009	Sensorhuispijp	41	116000066	Hogedrukschakelaar
8	113100009	Klem	42	116000071	Lagedrukschakelaar
9	108110038	Bovenframe	43	113010210	Uitlaatpijp
10	108110043	Ventilatormotorbeugel	44	117110021	Uitlaat temp. Sensor T6-TH3
11	117230003	Reactor	45	113020322	Gas retourleidingen
12	108480015	Riem fixeren	46	121000006	4-weg klep
13	108110004	Pijler	47	113060084	4-wegsklep naar collectieve leidingen
14	142000079	Verdamper verwarmingsriem	48	119000017	EEV
15	112000031	Ventilatormotor	49	113080054	EEV naar distributieleidingen
16	1330900261	Linkerkant paneel	50	113070044	Uitwisselaar van eev
17	108010024	Dc-motorafdekking	51	113900082	Wateraansluitsets
18	132000015	Waaierblad	52	112100021-1	Waterstroomschakelaar
19	133090025	Voorpaneel	53	133020011	Rode rubberen ring
20	108010014	Grill aan de voorkant	54	133020026	Rubberring op wateraansluiting
21	108050073	Isolatiepaneel	55	116000001	Afdichtring
22	113100008	Koppelgereedschap	56	117110011	Water uit temp. sensor T2-TH5
23	120000091	Globe-klep	57	117110012	Wisselaar sensor temperatuursensor
24	142000074	Compressor verwarmingsriem	58	102040708	Titanium warmtewisselaar
25	101000188	Demping voeten van de	59	133020011	Blauwe rubberen ring
26	101000188	Compressor	60	117110012	Water in temp. sensor T1-TH6
27	108110066	Basislade	61	150000110	Drainage plug
28	108010065	Eindprint	62	108050017	Elektrische deksel
29	1330900281	Rechter paneel	63	117100047	PCB
30	106000011	Manometer	64	108110057	Elektrische doos
31	136010004	Klem	65	117240002	Magneetring
32	115000004	5-zits terminal	66	117010095	Modbus-module
33	1332500051	Klemmenblokken plastic kap	67	117240003	Magneetring
34	133030011	Bedradingsdoos			

Model: 71679

NO	ERP	Naam van de onderdelen	NO	ERP	Naam van de onderdelen
1	1330900291	Bovenklep	35	113712007	Waterdichte controllerkast
2	117110020	Omgevingstemp. sensor T5-TH1	36	117020180	controleur
3	133020010	Omgevingstemp. sensor clip	37	103000220	Collectieve leidingen
4	1330900271	Achterpaneel	38	136020005	B-vormig rubber
5	103000220	Verdamper	39	103000220	Leidingen voor distributie
6	117110004	Pijp temp. sensor T3-TH2	40	113030081	4-wegklep naar wisselaar
7	113100009	Sensorhuispijp	41	116000066	Hogedrukschakelaar
8	113100009	Klem	42	116000071	Lagedrukschakelaar
9	108110038	Bovenframe	43	113010159	Uitlaatpijp
10	108110043	Ventilatormotorbeugel	44	117110021	Uitlaat temp. Sensor T6-TH3
11	117230003	Reactor	45	113020321	Gas retourleidingen
12	108480015	Verdamper verwarmingsriemclip	46	121000006	4-weg klep
13	108110004	Pijler	47	113060084	4-wegsklep naar collectieve leidingen
14	142000079	Verdamper verwarmingsriem	48	119000017	EEV
15	112000031	Ventilatormotor	49	113080054	EEV naar distributieleidingen
16	1330900261	Linkerkant paneel	50	113070041	Uitwisselaar van EEV
17	108010024	DC motorafdekking	51	113900082	Wateraansluitsets
18	132000015	Waaierblad	52	112100021-1	Waterstroomschakelaar
19	1330900251	Voorpaneel	53	133020012	Rode rubberen ring
20	108010014	Grill aan de voorkant	54	133020026	Rubberring op wateraansluiting
21	108050073	Isolatiepaneel	55	116000001	Afdichtring
22	113100008	Bies	56	117110011	Water uit temp. Sensor T2-TH5
23	120000091	Globe-klep	57	108010025	Wisselaar sensor temperatuursensor
24	142000074	Compressor verwarmingsriem	58	102040710	Titanium warmtewisselaar
25	101000181	Compressor rubberen voetjes	59	133020011	Blauwe rubberen ring
26	101000181	compressor	60	117110012	Water in temp. Sensor T1-TH6
27	108110044	Basislade	61	150000110	Drainage plug
28	108010065	Eindplank	62	108050017	Elektrische deksel
29	133090028	Rechter paneel	63	117100047	PCB
30	106000011	Manometer	64	108110045	Elektrische doos
31	136010004	Klem	65	117240002	Magneetring
32	115000004	5-zits terminal	66	117010095	Modbus-module
33	1332500051	Klemmenblokken plastic kap	67	117240003	Magneetring
34	133030011	Bedradingsdoos			

Model: 71680/71681

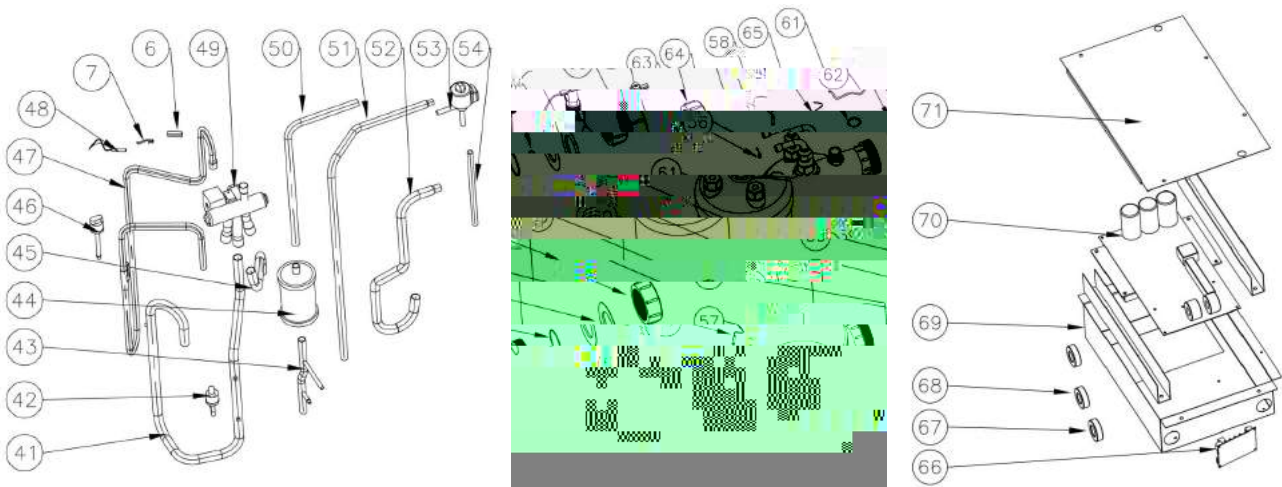

Model: 71680

NO	ERP	Naam van de onderdelen	NO	ERP	Naam van de onderdelen
1	1332600011	Bovenklep	37	1332600041	Rechter paneel
2	1332600021	Achterpaneel	38	103000230	Leidingen voor distributie
3	117110020	Omgevingstemp. sensor T5-TH1	39	136020005	Rubber blok
4	133020010	Omgevingstemp. sensor clip	40	103000230	Collectieve leidingen
5	103000230	Verdamper	41	113020338	Gas retourleidingen
6	113100009	Sensorhuispijp	42	116000073	Lagedrukschakelaar
7	113100009	Klem	43	113130021	Filter op vloeistofreservoir
8	117110004	Pijp temp. sensor T3-TH2	44	120000066	Filter
9	117230002	Reactor	45	113060122	4-wegsklep naar collectieve leidingen
10	108560003	Pijler	46	116000068	Hogedrukschakelaar
11	108560002	Bovenframe	47	113010244	Uitlaat
12	108480015	Riemklem	48	117110021	Uitlaat temp. sensor T6-TH3
13	142000079	Verdamper verwarmingsriem	49	121000006	4-weg klep
14	108560011	Ventilatormotorbeugel	50	113170032	Wisselaar om te filteren
15	112000031	Ventilatormotor	51	113120019	Vloeibare opslagtank naar EEV
16	132000023	Waaierblad	52	113030108	4-weg klep naar wisselaar
17	1332600051	Linkerkant paneel	53	119000021	EEV
18	1332600031	Voorpaneel	54	113080056	EEV naar distributieleidingen
19	108170017	Grill aan de voorkant	55	150000110	Drainage plug
20	108560036	Basislade	56	108010025	Wisselaar sensor temperatuursensor
21	101000185	Compressor	57	117110012	Water in temp. sensor T1-TH6
22	101000185	Demping voeten van de compressor	58	133020026	Rubberring op wateraansluiting
23	142000077	Compressor Verwarming riem	59	133020011	Blauwe rubberen ring
24	105000004	Vloeibare opslagtank	60	102040703	Titanium warmtewisselaar
25	108560010	Isolatiepaneel	61	113900082	Wateraansluitsets
26	120000091	Globe-klep	62	117110011	Water uit temp. sensor T2-TH5
27	108560034	Globe ventielbord	63	136020083	Afsluitring
28	113100008	Koperen buis	64	112100021-1	Waterstroomschakelaar
29	108010065	Vertrekhal bord	65	133020012	Rode rubberen ring
30	133030011	Bedradingsdoos	66	117010095	Modbus-module
31	136010004	Klem	67	117240002	Magneetring
32	106000011	Druk meter	68	117240003	Magneetring
33	1332500051	Klemmenblokken plastic kap	69	108560012	Elektrische doos
34	115000004	5-zits terminal	70	117100048	PCB
35	117020180	Controleur	71	108540006	Elektrische deksel
36	113712007	Waterdichte controllerkast			

Model: 71681

NO	ERP	Naam van de onderdelen	NO	ERP	Naam van de onderdelen
1	1332600011	Bovenklep	37	1332600041	Rechter paneel
2	1332600021	Achterpaneel	38	103000230	Leidingen voor distributie
3	117110020	Omgevingstemp. sensor T5-TH1	39	136020005	Rubber blok
4	133020010	Omgevingstemp. sensor clip	40	103000230	Collectieve leidingen
5	103000230	Verdamper	41	113020338	Gas retourleidingen
6	113100009	Sensorhuispijp	42	116000073	Lagedrukschakelaar
7	113100009	Klem	43	113130021	Filter op vloeistofreservoir
8	117110004	Pijp temp. sensor T3-TH2	44	120000066	Filter
9	117230002	Reactor	45	113060122	4-wegsklep naar collectieve leidingen
10	108560003	Pijler	46	116000068	Hogedrukschakelaar
11	108560002	Bovenframe	47	113010244	Uitlaat
12	108480015	Riemklem	48	117110021	Uitlaat temp. sensor T6-TH3
13	142000144	Verdamper verwarmingsriem	49	121000006	4-weg klep
14	108560011	Ventilatormotorbeugel	50	113170032	Wisselaar om te filteren
15	112000031	Ventilatormotor	51	113120019	Vloeibare opslagtank naar EEV
16	132000023	Waaierblad	52	113030108	4-weg klep naar wisselaar
17	1332600051	Linkerkant paneel	53	119000021	EEV
18	1332600031	Voorpaneel	54	113080056	EEV naar distributieleidingen
19	108170017	Grill aan de voorkant	55	150000110	Drainage plug
20	108560036	Basislade	56	108010025	Wisselaar sensor temperatuursensor
21	101000185	Compressor	57	117110012	Water in temp. sensor T1-TH6
22	101000185	Demping voeten van de compressor	58	133020026	Rubberring op wateraansluiting
23	142000077	Compressor Verwarming riem	59	133020011	Blauwe rubberen ring
24	105000004	Vloeibare opslagtank	60	102040703	Titanium warmtewisselaar
25	108560010	Isolatiepaneel	61	113900082	Wateraansluitsets
26	120000091	Globe-klep	62	117110011	Water uit temp. sensor T2-TH5
27	108560034	Globe ventielbord	63	136020083	Afsluitring
28	113100008	Koperen buis	64	112100021-1	Waterstroomschakelaar
29	108010065	Vertrekhal bord	65	133020012	Rode rubberen ring
30	133030011	Bedradingsdoos	66	117010095	Modbus-module
31	136010004	Klem	67	117240002	Magneetring
32	106000011	Druk meter	68	117240003	Magneetring
33	1332500051	Klemmenblokken plastic kap	69	108560012	Elektrische doos
34	115000004	5-zits terminal	70	117100048	PCB
35	117020180	Controleur	71	108540006	Elektrische deksel
36	113712007	Waterdichte controllerkast			

Model: 71682/71683

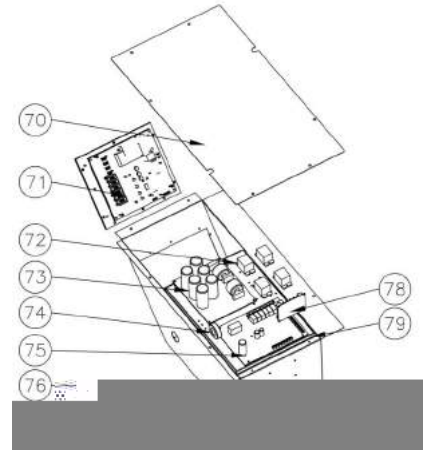
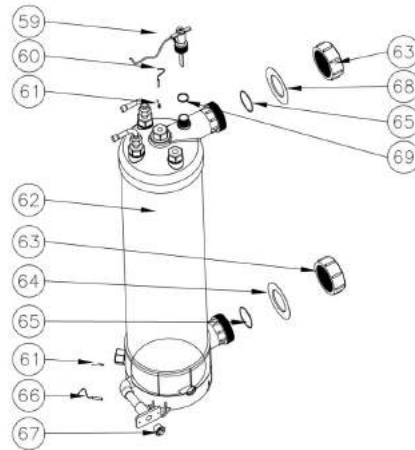
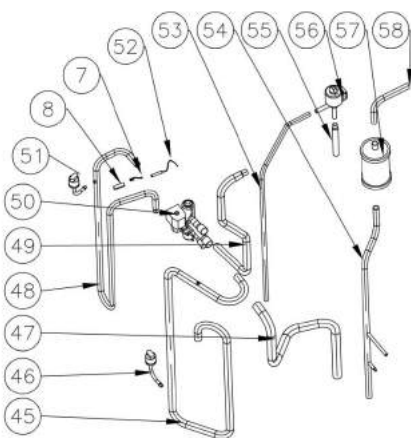
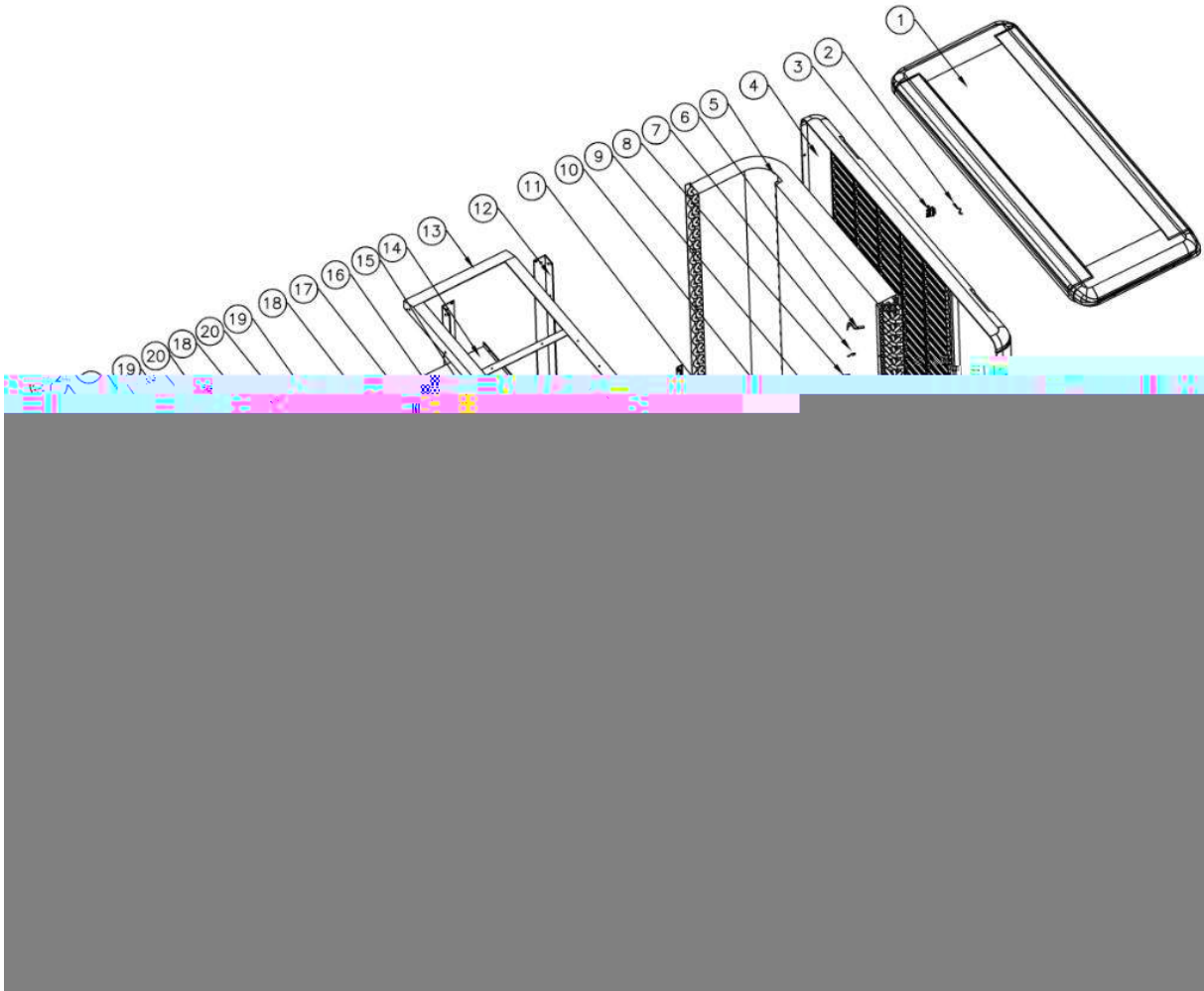

Model: 71682

NO	ERP	Naam van de onderdelen	NO	ERP	Naam van de onderdelen
1	133100001	Bovenklep	41	117020180	Controleur
2	117110020	Omgevingstemp. sensor T5-TH1	42	113712007	Waterdichte controllerkast
3	133020010	Omgevingstemp. sensor clip	43	103000208	Collectieve leidingen
4	133250003	Achterpaneel	44	136020005	Rubber blok
5	103000208	Verdamper	45	113020326	Gas retourleidingen
6	117110004	Pijp temp. sensor T3-TH2	46	116000073	Lagedrukschakelaar
7	113100009	Klem	47	113060083	4-wegsklep naar collectieve leidingen
8	113100009	Sensorhuispijp	48	113010227	Uitlaat
9	103000208	Leidingen voor distributie	49	113030087	4-weg klep naar wisselaar
10	108120036	Isolatiepaneel	50	121000009	4-weg klep
11	117230001	Reactor	51	116000008	Hogedrukschakelaar
12	108120035	Pijler	52	117110021	Uitlaat temp. sensor T6-TH3
13	108120034	Bovenframe	53	113120020	Vloeibare opslagtank naar EEV
14	108120044	Ventilatormotorbeugel	54	113130020	Filter op vloeistofreservoir
15	108480015	Riemklem	55	113080055	EEV naar distributieleidingen
16	142000079	Verdamper verwarmingsriem	56	119000021	EEV
17	108550009	Pijler	57	120000066	Filter
18	112000031	Ventilatormotor	58	113170028	Wisselaar om te filteren
19	132000015	Waaierblad	59	112100021-1	Waterstroomschakelaar
20	108010024	DC-motor afdekking	60	117110011	Water uit temp. sensor T2-TH5
21	133250004	Linkerkant paneel	61	108010025	Wisselaar sensor temperatuursensor
22	133250001	Voorpaneel	62	102040749	Titanium warmtewisselaar
23	108010014	Grill aan de voorkant	63	113900082	Wateraansluitsets
24	120000091	Globe-klep	64	133020012	Blauwe rubberen ring
25	113100008	Koperen buis	65	133020026	Rubberring op wateraansluiting
26	101000185	Compressor	66	117110012	Water in temp. sensor T1-TH6
27	101000185	Demping voeten van de compressor	67	150000110	Drainage plug
28	105000008	Vloeibare opslagtank	68	133020011	Rode rubberen ring
29	142000077	Compressor Verwarming riem	69	136020083	Afsluitring
30	108550005	Basislade	70	108120040	Elektrische deksel
31	108550008	Handvat pijler	71	117140016	Bestuurdersbord
32	108010065	Vertrekhal bord	72	142000038	Relais
33	133250002	Rechter paneel	73	117260001	Filter bord
34	115000025	Terminal met 3 zitplaatsen voor elektriciteit	74	117240002	Magneetring
35	106000011	Druk meter	75	117250007	PCB
36	136010004	Klem	76	108120038	Elektrische doos
37	108550006	Pijler	77	117240003	Magneetring
38	115000027	Terminal met 3 zitplaatsen voor waterpomp	78	117010095	Modbus-module
39	133250005	Klemmenblokken plastic kap	79	108120039	Schaalbord
40	133030011	Bedradingsdoos			

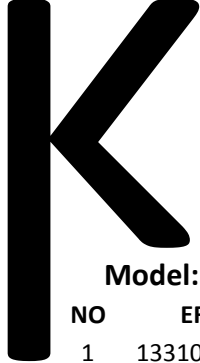

Model: 71683

NO	ERP	Naam van de onderdelen	NO	ERP	Naam van de onderdelen
1	133100001	Bovenklep	41	117020180	Controleur
2	117110020	Omgevingstemp. sensor T5-TH1	42	113712007	Waterdichte controllerkast
3	133020010	Omgevingstemp. sensor clip	43	103000209	Collectieve leidingen
4	133250003	Achterpaneel	44	136020005	Rubber blok
5	103000209	Verdamper	45	113020389	Gas retourleidingen
6	117110004	Pijp temp. sensor T3-TH2	46	116000073	Lagedrukschakelaar
7	113100009	Klem	47	113060083	4-wegsklep naar collectieve leidingen
8	113100009	Sensorhuispijp	48	113010228	Uitlaat
9	103000209	Leidingen voor distributie	49	113030087	4-weg klep naar wisselaar
10	108120036	Isolatiepaneel	50	121000009	4-weg klep
11	117230001	Reactor	51	116000008	Hogedrukschakelaar
12	108120035	Pijler	52	117110021	Uitlaat temp. sensor T6-TH3
13	108120034	Bovenframe	53	113120020	Vloeibare opslagtank naar EEV
14	108120044	Ventilatormotorbeugel	54	113130020	Filter op vloeistofreservoir
15	108480015	Riemklem	55	113080055	EEV naar distributieleidingen
16	142000079	Verdamper verwarmingsriem	56	119000042	EEV
17	108550009	Pijler	57	120000066	Filter
18	112000031	ventilator	58	113170028	Wisselaar om te filteren
19	132000015	Waaierblad	59	112100021-1	Waterstroomschakelaar
20	108010024	DC-motor afdekking	60		

Model: 68821/68822/68823

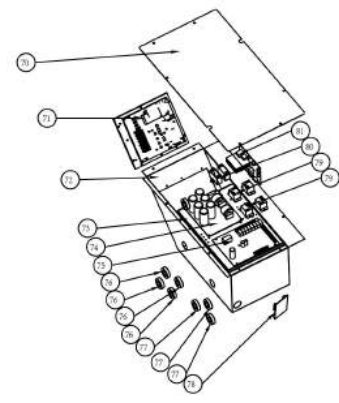
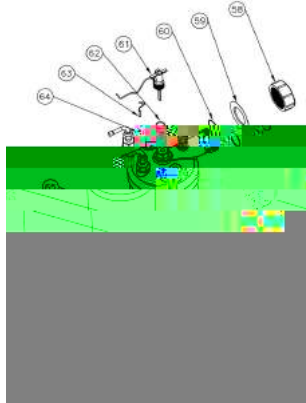
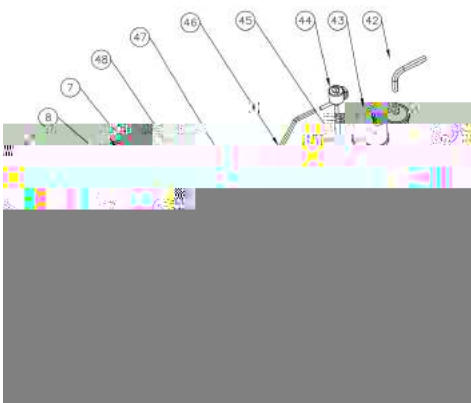
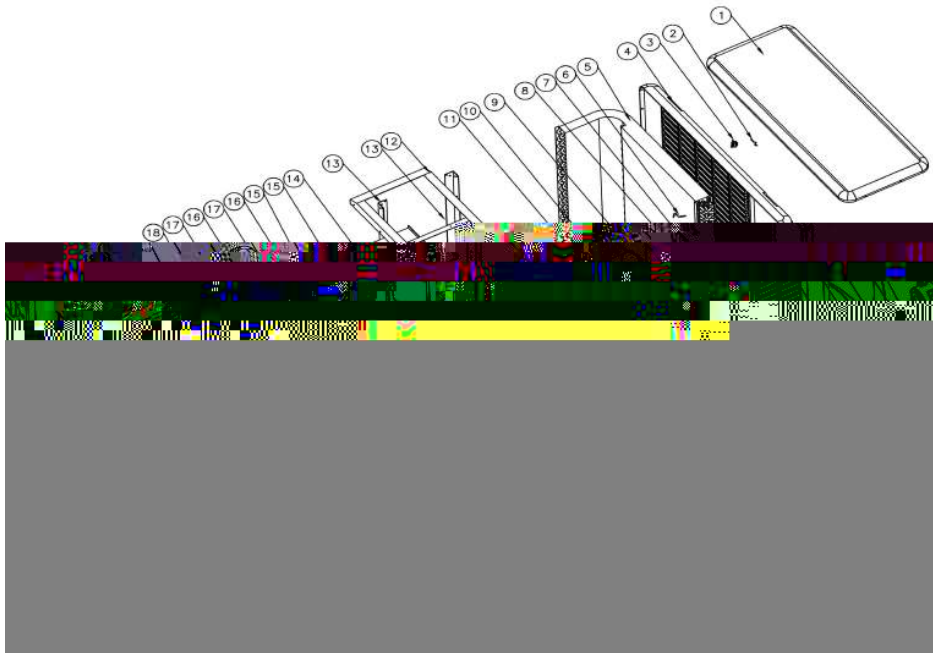

Model: 68821

NO	ERP	Naam van de onderdelen	NO	ERP	Naam van de onderdelen
1	133100001	Bovenklep	41	113050109	Collectieve leidingen
2	117110020	Omgevingstemp. sensor T5-TH1	42	113170028	Wisselaar om te filteren
3	133020010	Omgevingstemp. sensor clip	43	120000066	Filter
4	133250003	achterpaneel	44	119000022	EEV
5	103000153	Verdamper	45	113080055	EEV naar distributieleidingen
6	117110004	Pijp temp. sensor T3-TH2	46	113120020	Vloeibare opslagtank naar EEV
7	113190001	Klem	47	113030087	4-weg klep naar wisselaar
8	113190001	Sensorhuispijp	48	117110021	Uitlaat temp. sensor T6-TH3
9	113040101	Leidingen voor distributie	49	116000008	Hogedrukschakelaar
10	108550010	Isolatiepaneel	50	121000009	4-weg klep
11	117230002	Reactor	51	120000023	Zuig ventiel
12	108120034	Bovenframe	52	113010158	Uitlaat
13	108120035	Pijler	53	116000080	Lagedrukschakelaar 0.2-0.35
14	108120037	Ventilatormotorbeugel	54	116000079	Lagedrukschakelaar 0.1-0.3
15	112000031	Ventilatormotor	55	113020245	Gas retourleidingen
16	108010024	Ventilator motorpijp afdekking	56	113060083	4-wegsklep naar collectieve
17	132000015	Waaierblad	57	113130015	Filter op vloeistofreservoir
18	133250004	Linkerkant paneel	58	113900082	Watersluitsets
19	133250001	Voorpaneel	59	133020011	Rode rubberen ring
20	108010014	Grill aan de voorkant	60	133020026	Rubberring op watersluiting
21	108550009	Pijler	61	112100021-1	Waterstroomschakelaar
22	108550005	Basilade	62	116000001-2	Afsluitring
23	101000149	Compressor	63	117110011	Water uit temp. sensor T2-TH5
24	105000008	Vloeibare opslagtank	64	108010025	Wisselaar sensor
25	142000077	Compressor Verwarming riem	65	113900082	Watersluitsets
26	101000149	Demping voeten van de compressor	66	133020012	Blauwe rubberen ring
27	108550008	Handvat pijler	67	102040503	Titanium warmtewisselaar
28	108010065	Vertrekhal bord	68	117110012	Water in temp. sensor T1-TH6
29	110000008	Draadverbinding	69	150000110	Drainage plug
30	108010018	Bedradingsdoos	70	108120040	Elektrische deksel
31	133250002	Rechter paneel	71	117140003	Bestuurdersbord
32	115000025	Terminal met 3 zitplaatsen voor elektriciteit	72	108120038	Elektrische doos
33	110800001	Druk meter	73	108120039	Schaalbord
34	136010004	Klem	74	117260002	Filter bord
35	108550006	Pijler	75	117250001-V1.5	PCB
36	115000027	Terminal met 3 zitplaatsen voor waterpomp	76	117240002	Magneetring
37	133250005	Klemmenblokken plastic kap	77	117240003	Magneetring
38	113712007	Waterdichte controllerkast	78	117010095	Modbus-module
39	117020150	Controleur	79	142000038	Relais
40	136020005	Rubber blok	80	N/A	N/A
			81	117140006	Bestuurderskaart ventilatormotor

Model: 68822

NO	ERP	Naam van de onderdelen	NO	ERP	Naam van de onderdelen
1	133100001	Bovenklep	41	113050110	Collectieve leidingen
2	117110020	Omgevingstemp. sensor T5-TH1	42	113170028	Wisselaar om te filteren
3	133020010	Omgevingstemp. sensor clip	43	120000066	Filter
4	133250003	Achterpaneel	44	119000022	EEV
5	103000154	Verdamper	45	113080055	EEV naar distributieleidingen
6	117110004	Pijp temp. sensor T3-TH2	46	113120020	Vloeibare opslagtank naar EEV
7	113190001	Klem	47	113030087	4-weg klep naar wisselaar
8	113190001	Sensorhuispijp	48	117110021	Uitlaat temp. sensor T6-TH3
9	113040102	Leidingen voor distributie	49	116000008	Hogedrukschakelaar
10	108550010	Isolatiepaneel	50	121000009	4-weg klep
11	117230004	Reactor	51	120000023	Zuig ventiel
12	108120034	Bovenframe	52	113010158	Uitlaat
13	108120035	Pijler	53	116000080	Lagedrukschakelaar 0.2-0.35
14	108120037	Ventilatormotorbeugel	54	116000079	Lagedrukschakelaar 0.1-0.3
15	112000031	Ventilatormotor	55	113020245	Gas retourleidingen
16	108010024	Ventilator motorpijp afdekking	56	113060083	4-wegsklep naar collectieve leidingen
17	132000015	Waaierblad	57	113130015	Filter op vloeistofreservoir
18	133250004	Linkerkant paneel	58	113900082	Watersaansluitsets
19	133250001	Voorpaneel	59	133020011	Rode rubberen ring
20	108010014	Grill aan de voorkant	60	133020026	Ruberring op watersaansluiting
21	108550009	Pijler	61	112100021-1	Waterstroomschakelaar
22	108550005	Basislade	62	116000001-2	Afsluitring
23	101000122	Compressor	63	117110011	Water uit temp. sensor T2-TH5
24	105000008	Vloeibare opslagtank	64	108010025	Wisselaar sensor temperatuursensor
25	142000077	Compressor Verwarming riem	65	113900082	Watersaansluitsets
26	101000122	Demping voeten van de compressor	66	133020012	Blauwe rubberen ring
27	108550008	Handvat pijler	67	102040502	Titanium warmtewisselaar
28	108010065	Vertrekhal bord	68	117110012	Water in temp. sensor T1-TH6
29	110000008	Draadverbinding	69	150000110	Drainage plug
30	108010018	Bedradingsdoos	70	108120040	Elektrische deksel
31	133250002	Rechter paneel	71	117140002	Bestuurdersbord
32	115000025	Terminal met 3 zitplaatsen voor elektriciteit	72	108120038	Elektrische doos
33	110800001	Druk meter	73	108120039	Schaalbord
34	136010004	Klem	74	117260001	Filter bord
35	108550006	Pijler	75	117250001-V1.5	PCB
36	115000027	Terminal met 3 zitplaatsen voor waterpomp	76	117240002	Magneetring
37	133250005	Klemmenblokken plastic kap	77	117240003	Magneetring
38	113712007	Waterdichte controllerkast	78	117010095	Modbus-module
39	117020150	Controleur	79	142000038	Relais
40	136020005	Rubber blok	80	N/A	N/A
			81	N/A	N/A

Model: 68823

NO	ERP	Naam van de onderdelen	NO	ERP	Naam van de onderdelen
1	133100001	Bovenklep	41	113050110	Collectieve leidingen
2	117110020	Omgevingstemp. sensor T5-TH1	42	113170028	Wisselaar om te filteren
3	133020010	Omgevingstemp. sensor clip	43	120000066	Filter
4	133250003	Achterpaneel	44	119000022	EEV
5	103000154	Verdamper	45	113080055	EEV naar distributieleidingen
6	117110004	Pijp temp. sensor T3-TH2	46	113120020	Vloeibare opslagtank naar EEV
7	113190001	Klem	47	113030087	4-weg klep naar wisselaar
8	113190001	Sensorhuispijp	48	117110021	Uitlaat temp. sensor T6-TH3
9	113040102	Leidingen voor distributie	49	116000008	Hogedrukschakelaar
10	108550010	Isolatiepaneel	50	121000009	4-weg klep
11	117230002	Reactor	51	120000023	Zuig ventiel
12	108120034	Bovenframe	52	113010158	Uitlaat
13	108120035	Pijler	53	116000080	Lagedrukschakelaar 0.2-0.35
14	108120037	Ventilatormotorbeugel	54	116000079	Lagedrukschakelaar 0.1-0.3
15	112000031	Ventilatormotor	55	113020245	Gas retourleidingen
16	108010024	Ventilator motorpijp afdekking	56	113060083	4-wegsklep naar collectieve leidingen
17	132000015	Waaierblad	57	113130015	Filter op vloeistofreservoir
18	133250004	Linkerkant paneel	58	113900082	Wateraansluitsets
19	133250001	Voorpaneel	59	133020011	Rode rubberen ring
20	108010014	Grill aan de voorkant	60	133020026	Rubberring op wateraansluiting
21	108550009	Pijler	61	112100021-1	Waterstroomschakelaar
22	108550005	Basislade	62	116000001-2	Afsluitring
23	101000149	Compressor	63	117110011	Water uit temp. sensor T2-TH5
24	105000008	Vloeibare opslagtank	64	108010025	Wisselaar sensor temperatuursensor
25	142000077	Compressor Verwarming riem	65	113900082	Wateraansluitsets
26	101000149	Demping voeten van de compressor	66	133020012	Blauwe rubberen ring
27	108550008	Handvat pijler	67	102040502	Titanium warmtewisselaar
28	113712007	Vertrekhal bord	68	117110012	Water in temp. sensor T1-TH6
29	110000008	Draadverbinding	69	150000110	Drainage plug
30	108010018	Bedradingsdoos	70	108120040	Elektrische deksel
31	133250002	Rechter paneel	71	117140003	Bestuurdersbord
32	115000006	Terminal met 3 zitplaatsen voor elektriciteit	72	108120038	Elektrische doos
33	110800001	Druk meter	73	108120039	Schaalbord
34	136010004	Klem	74	117260002	Filter bord
35	108550006	Pijler	75	117250001-V1.5	PCB
36	115000027	Terminal met 3 zitplaatsen voor waterpomp	76	117240002	Magneetring
37	133250005	Klemmenblokken plastic kap	77	117240003	Magneetring
38	113712007	Waterdichte controllerkast	78	117010095	Modbus-module
39	117020150	Controleur	79	142000038	Relais
40	136020005	Rubber blok	80	N/A	N/A
			81	117140006	Bestuurderskaart ventilatormotor

9.2. Onderhoud

- (1) U moet het water voorziening systeem regelmatig controleren om te voorkomen dat lucht het systeem binnentreedt en lage water doorvoer voorkomen, omdat het de prestaties en betrouwbaarheid van het HP apparaat kan verminderen.
- (2) Reinig uw zwembaden en filter systeem regelmatig om schade aan het apparaat te vermijden als een resultaat van een vuil of verstopt filter.
- (3) U moet het water van de bodem van de waterpomp aftappen als het apparaat niet wordt gebruikt voor een langere periode (speciaal tijdens het winterseizoen).
- (4) In omgekeerde manier, moet u controleren dat het apparaat volledig met water gevuld is voordat u het apparaat weer opnieuw opstart.
- (5) Nadat het apparaat gereedgemaakt is voor het winterseizoen, is het beter om het te beschermen met een speciale winter verwarming pomp.
- (6) Wanneer het apparaat werkt, is er de gehele tijd een klein water verlies onder het apparaat.
- (7) De werking van vulgas moet door een professional met R32-exploitatievergunning worden uitgevoerd.
- (8) Vul het R32-gas van de Globe-klep in de machine in.



Bomba de calor para Piscina

PRO ELYO INVERBOOST NN

1. Descripción
2. Información de transporte
3. Ficha Técnica
4. Kit de instalación
5. Localización y conexión
6. Cableado Eléctrico
7. Puesta en marcha de la bomba de calor
8. Solución de Problemas
9. Diagrama de despiece y Mantenimiento



ATENCIÓN:

- La operación y el mantenimiento en función del tiempo y la frecuencia recomendada en el manual.
- Utilice únicamente piezas de repuesto estándar.
- Operación y mantenimiento en el tiempo y la frecuencia recomendada de este manual.

Gracias por usar la bomba de calor PRO ELYO INVERBOOST NN para el calentamiento de su piscina, calentará el agua de la piscina y mantendrá la temperatura constante cuando la temperatura ambiente esté entre -20 y 50 °C.

ADVERTENCIA:

- * Por favor, siempre vacíe el agua de la bomba de calor cuando esté parada durante el invierno o cuando la temperatura ambiente descienda por debajo de 0 °C, o de lo contrario, el intercambiador de titanio se dañará por congelación, en tal caso, se perderá la garantía.
- * Por favor, siempre corte el suministro de energía si desea abrir la carcasa para alcanzar el interior de la bomba de calor, porque hay electricidad de alto voltaje en el interior.
- * Por favor, mantenga el controlador en un lugar seco, o bien cierre la cubierta de aislamiento para proteger el controlador de daños causados por la humedad.

Noticia importante:

- Mantenga siempre la bomba de calor en un lugar ventilado y lejos de cualquier objeto que pueda provocar un incendio.
- No sude la tubería si hay refrigerante dentro de la máquina. Mantenga la máquina fuera de espacios confinados cuando realice el llenado de gas.
- Se debe hacer el vacío a la bomba de calor antes de cargar el gas R32 por la válvula de cierre, situada dentro de la máquina.

1.1 Con su Bomba de Calor se suministra:

- Conexión agua de 50 mm (pcs: 2)
- Manual de instrucciones y servicio
- Conexión condensados
- 10 metros de cable de señal
- Caja estanca
- Cubierta invernal
- Base de anti-vibración (pcs: 4)

1.2 Dimensión

Modelo: 71676

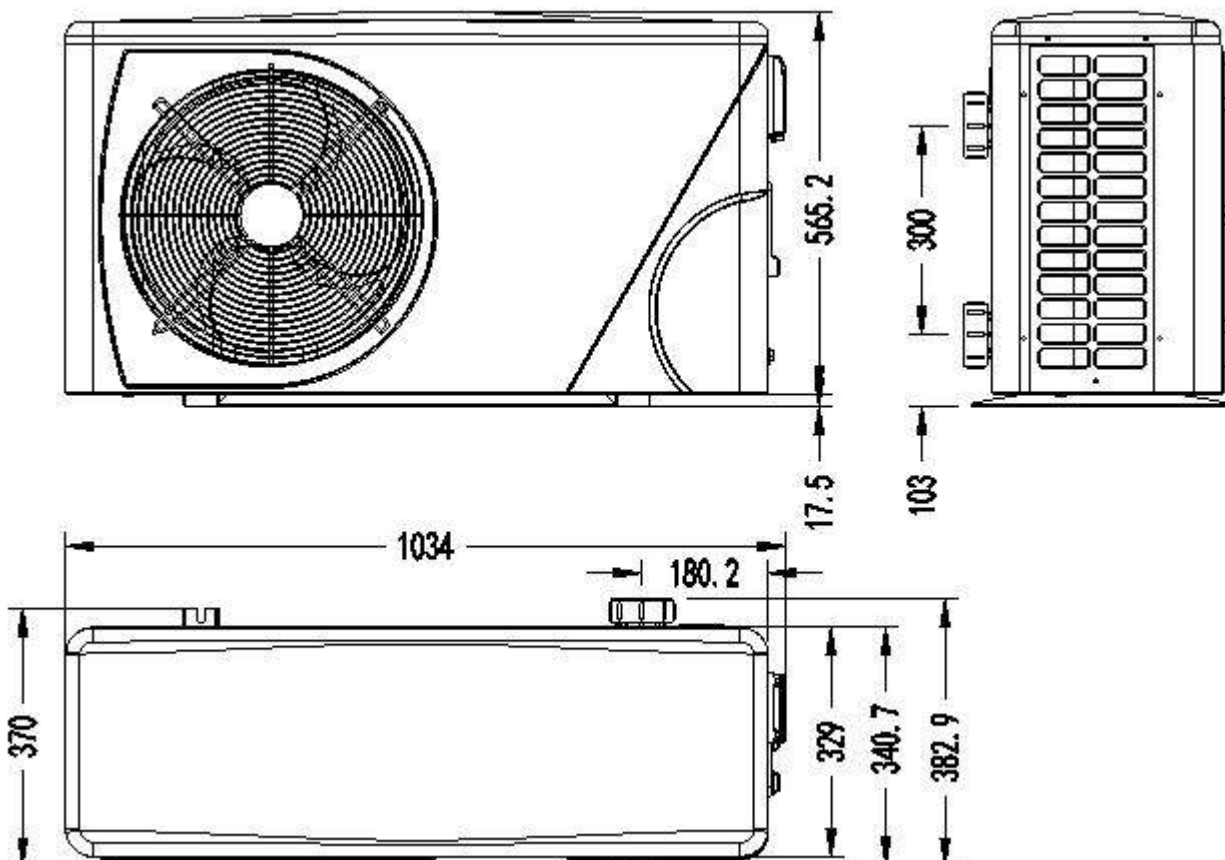

Modelo : 71682/71683/68821/68822/68823



2.1 Entrega del embalaje



Para el transporte, la bomba de calor se fija en el palet y se cubre con una caja de cartón.

Para preservar de cualquier daño, la bomba de calor debe ser trasladada con una transpaleta.

Todo el material, incluso si el transporte es imputable al proveedor, puede dañarse durante su traslado a casa del cliente y es responsabilidad del destinatario asegurarse de su correcta entrega.

El destinatario tiene que escribir todas las reseñas a la recepción en el albarán de entrega del transportista si nota daños en el embalaje. NO OLVIDE CONFIRMAR POR CARTA CERTIFICADA AL TRANSPORTISTA ANTES DE 48 H.

2.2 Consejo de stock



* El almacén debe estar limpio, espacioso, abierto, bien ventilado, con equipo de ventilación y sin fuente de fuego.

* La bomba de calor debe almacenarse y transportarse en posición vertical en su embalaje original. Si no es el caso, no se puede conectar de inmediato, es necesario un período mínimo de 24 horas antes de encender la energía eléctrica.

PROHIBIDO



2.3 Transferencia a la posición final

* Durante el desembalaje del producto y la transferencia desde el palet hasta el lugar final, es necesario mantener en posición vertical la bomba de calor.

* Está prohibido fumar y el uso de llamas cerca de la máquina R32.

* La conexión de agua no garantiza la sujeción de la máquina, por el contrario, el peso de la bomba de calor pueda dañar las conexiones de agua ocasionando averías en el producto. El fabricante no se responsabiliza de los daños ocasionados por una incorrecta instalación.

Datos técnicos de bombas de calor de piscina PRO ELYO INVERBOOST NN

Norma CE, R32, carcasa ABS

MODELO		PROELYXP07i	PROELYXP09i	PROELYXP11i	PROELYXP14i
CÓDIGO		71676	71677	71678	71679
* Rendimiento en aire 28 °C, agua 28 °C, humedad 80%					
Potencia Calor	Kw	7-3.1	9-2.3	11-2.9	14-3.2
Consumo de energía	Kw	1.04-0.21	1.34-0.14	1.64-0.18	2.09-0.2
C.O.P.		15-6.7	16-6.7	16-6.7	16-6.7
* Rendimiento en aire 15 °C, agua 26 °C, humedad 70%					
Potencia Calor	Kw	4.7-2.5	6.6-1.9	7.9-2	9.5-2.3
Consumo de energía	Kw	0.94-0.32	1.32-0.24	1.58-0.25	1.9-0.29
C.O.P.		7.9-5	8.0-5	8.0-5	8.0-5
* Rendimiento en aire 0 °C, agua 26 °C, humedad 78%					
Potencia Calor	Kw	3.44-1.7	4.11-2.3	5.54-3.0	6.85-3.8
Consumo de energía	Kw	1.23-0.38	1.47-0.82	1.98-0.68	2.45-0.85
C.O.P.		4.5-2.8	4.4-2.8	4.4-2.8	4.5-2.8
* Rendimiento en aire -10 °C, agua 26 °C, humedad 78%					
Potencia Calor	Kw	2.41-1.5	3.13-2.0	3.87-2.7	5.1-3.15
Consumo de energía	Kw	1.21-0.35	1.42-0.53	1.76-0.69	2.32-0.81
C.O.P.		4.3-2	3.8-2.2	3.9-2.2	3.9-2.2
* Información General					
Tipo de compresor		MITSUBISHI INVERTER COMPRESSOR			
Voltaje	V	220-240V/50Hz or 60Hz/1PH			
Corriente nominal	A	4.6	5.9	7.2	9.2
Fusible mínimo	A	7	9	11	14
Volumen de piscina	m ³	10-26	12-35	16-60	18-66
Caudal de agua óptimo	m ³ /h	2.5	3.0	3.7	4.0
Caída de presión de agua	Kpa	12	12	14	15
Intercambiador de calor		Tubo de titanio torcido en PVC			
Conexión de agua	mm	50			
Nº de ventiladores		1			
Tipo de ventilación		Horizontal			
Velocidad del ventilador	RPM	500-850		550-850	
Consumo ventilador	W	6-35		22-82	32-110
Nivel de ruido (10m)	dB(A)	≤ 41	≤ 42	≤ 42	≤ 43
Nivel de ruido (1m)	dB(A)	38-51	39-52	40-52	40-54
Refrigerante (R32)	g	650	700	1000	1100
CO2 equivalente	Tonne	0.44	0.47	0.68	0.74
* Dimensión / Peso					
Peso neto	kg	56	68	73	78
Peso bruto	kg	68	73	78	83
Dimensión neta	mm	1008*380*577		1050*440*709	
Dimensión de embalaje	mm	1095*430*705		1130*470*850	

Los datos anteriores están sujetos a modificaciones sin previo aviso

MODELO		PROELYXP16i	PROELYXP20i	PROELYXP26i	PROELYXP30i
CÓDIGO		71680	71681	71682	71683
* Rendimiento en aire 28 °C, agua 28 °C, humedad 80%					
Potencia Calor	Kw	16-3.8	20-4.7	26-5.9	30-6.8
Consumo de energía	Kw	2.39-0.24	2.99-0.29	3.88-0.37	4.55-0.43
C.O.P.		16-6.7	16-6.7	16-6.7	16-6.6
* Rendimiento en aire 15 °C, agua 26 °C, humedad 70%					
Potencia Calor	Kw	11.2-3	14-3.9	18-5.4	22.8-5.6
Consumo de energía	Kw	2.24-0.38	2.8-0.49	3.6-0.68	4.56-0.68
C.O.P.		8.2-5	8.2-5	8.2-5	8.2-5
* Rendimiento en aire 0 °C, agua 26 °C, humedad 78%					
Potencia Calor	Kw	7.4-4.1	9.79-4.8	13-6.7	15.89-8.5
Consumo de energía	Kw	2.64-0.91	3.5-1.09	4.64-1.52	5.68-1.93
C.O.P.		4.5-2.8	4.4-2.8	4.4-2.8	4.4-2.8
* Rendimiento en aire -10 °C, agua 26 °C, humedad 78%					
Potencia Calor	Kw	5.8-3.6	7.58-4.3	10.4-5.9	12.74-7.4
Consumo de energía	Kw	2.64-0.92	3.45-1.1	4.73-1.51	5.79-1.95
C.O.P.		3.9-2.2	3.9-2.2	3.9-2.2	3.8-2.2
* Información General					
Tipo de compresor		MITSUBISHI INVERTER COMPRESSOR			
Voltaje	V	220V-240V/50Hz or 60Hz/1PH			
Corriente nominal	A	10.5	13.2	17.0	23.0
Fusible mínimo	A	16	20	26	35
Volumen de piscina	m ³	28-85	58-120	65-132	78-156
Caudal de agua óptimo	m ³ /h	5.0	6.0	8.0	10.0
Caída de presión de agua	Kpa	15	18	20	25
Intercambiador de calor		Twist-titanium tube in PVC			
Conexión de agua	mm	50			
Nº de ventiladores		1			
Tipo de ventilación		Horizontal			
Velocidad del ventilador	RPM	450-650		(550-850)*2	
Consumo ventilador	W	35-130		(32-110)*2	
Nivel de ruido (10m)	dB(A)	≤ 43	≤ 45	≤ 49	≤ 49
Nivel de ruido (1m)	dB(A)	40-54	41-56	42-60	42-60
Refrigerante (R32)	g	1500	1900	2000	2600
CO2 equivalente	Tonne	1.01	1.28	1.35	1.76
* Dimensión / Peso					
Peso neto	kg	98	117	128	130
Peso bruto	kg	113	135	146	148
Dimensión neta	mm	1050*450*870		1050*452*1295	
Dimensión de embalaje	mm	1140*480*1010		1130*515*1430	

Los datos anteriores están sujetos a modificaciones sin previo aviso

Potencia Calor	Kw	26-5.9	35-8	35-8
Consumo de energía	Kw	3.88-0.37	5.22-0.5	5.22-0.5
C.O.P.		16-6.7	16-6.7	16-6.7
* Rendimiento en aire 15 °C, agua 26 °C, humedad 70%				
Potencia Calor	Kw	18-5.4	24-5.6	24-5.6
Consumo de energía	Kw	3.6-0.68	4.8-0.68	4.8-0.68
C.O.P.		8.2-5	8.2-5	8.2-5
* Rendimiento en aire 0 °C, agua 16 °C, humedad 78%				
Potencia Calor	Kw	13-6.7	15.8-3.7	15.8-3.7
Consumo de energía	Kw	4.64-1.52	4.46-0.63	4.46-0.63
C.O.P.		4.4-2.8	5.8-3.6	5.8-3.6
* Rendimiento en aire -10 °C, agua 6 °C, humedad 78%				
Potencia Calor	Kw	10.4-5.9	11.6-3.1	11.6-3.1
Consumo de energía	Kw	4.73-1.51	4.77-0.6	4.77-0.6
C.O.P.		3.9-2.2	5.2-2.45	5.2-2.45

*** Informacion General**

Tipo de compresor

MITSUBISHI INVERTOR COMPRESSOR

Voltaje

50Hz or 60Hz/3PH

200~240V /50Hz or

200~240V /60Hz/1PH

Equipo









 <p>Base antivibraciones, 4 pcs</p>	 <p>Pipeta de desagüe, 2 pcs</p>	 <p>Caja estanca, 1 pc</p>
 <p>Cable de señal 10M, 1 pc Cable de señal Modbus, 1 pc</p>	 <p>Conexión de agua, 2 set</p>	 <p>Cubierta de invierno, 1 pc</p>

4.2 Kit By-Pass

El kit de By-Pass es el accesorio indispensable para la instalación de la bomba de calor; también es una herramienta para la optimización de la calefacción

B

4. 3 Accesorios de instalación

	<p>Bases antivibratorias</p> <ol style="list-style-type: none"> 1. Sacar 4 bases antivibratorias 2. Póngalos uno por uno en la parte inferior de la máquina.
 	<p>Conexión de la pipeta de desagüe</p> <ol style="list-style-type: none"> 1. Instale la pipeta de desagüe debajo del panel inferior 2. Conecte una tubería para drenar el agua. <p>Nota: Levante la bomba de calor para instalar la pipeta. Nunca vuelque la bomba de calor, podría dañar el compresor.</p>
 	<p>Entrada y salida de agua</p> <ol style="list-style-type: none"> 1. Instale las dos juntas como muestra la imagen 2. Enrosquelas en las tomas de agua. <p>Juntas de entrada y salida</p>
 	<p>Cableado</p> <ol style="list-style-type: none"> 1. Abra la caja del bornero (marcada en rojo) en el lado de la máquina 2. Conecte los cables de alimentación en las bornas como indica la imagen.
 	<p>Conexión de la bomba de filtración (contacto libre de tensión)</p> <ol style="list-style-type: none"> 1. Abra la caja bornas (marcada en rojo) en el lado de la máquina 2. Conecte los cables del sistema de filtración en las bornas, como indica la imagen.

ATENCIÓN:

Tenga en cuenta las siguientes reglas para la instalación de la bomba de calor:

1. Cualquier adición de productos químicos debe tener lugar en la tubería situada aguas abajo de la bomba de calor.
2. Siempre coloque la bomba de calor sobre una base sólida y nivelada. Utilice los soportes de goma incluidos para evitar la vibración y el ruido.
3. Mantenga siempre la bomba de calor en posición vertical. Si la unidad se ha trasladado con inclinación, espere por lo menos 24 horas antes de poner en marcha la bomba de calor.

5.1 Ubicación de la bomba de calor

La unidad funcionará correctamente en cualquier lugar deseado siempre que los siguientes tres elementos estén presentes:

1. Aire fresco
2. Electricidad
3. Los filtros de la piscina

La unidad se puede instalar prácticamente en cualquier lugar al aire libre, siempre y cuando se mantengan las distancias mínimas especificadas a otros objetos (vea el dibujo de abajo). Por favor, consulte a su instalador para la instalación en una piscina cubierta. La instalación en un lugar ventoso no presenta ningún problema en, a diferencia con un calentador de gas.

ATENCIÓN: Está prohibido instalar la unidad en una habitación cerrada con un volumen de aire limitado en el que se volverá a utilizar el aire expulsado de la unidad, o cerca de arbustos que podrían bloquear la entrada de aire. Tales ubicaciones perjudican el suministro continuo de aire fresco, lo que implicará una reducción de la eficiencia y, posiblemente, reducción de la producción de calentamiento.

Ver el dibujo de abajo para las dimensiones mínimas.

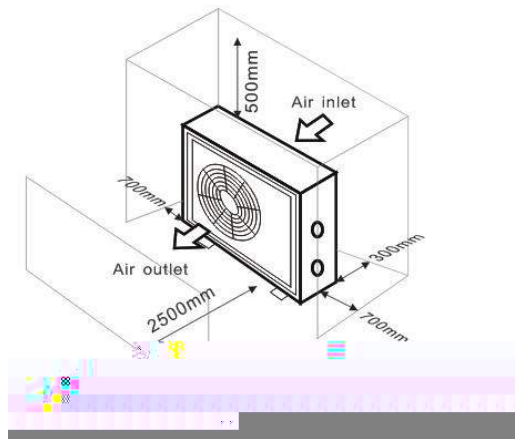

5.2 Comprobar la válvula de la instalación

⚠ NOTA

Nota: Si se utiliza un equipo de dosificación automática para el cloro y la acidez (pH), es esencial para proteger la bomba de calor contra concentraciones químicas excesivamente altas que puedan corroer el intercambiador de calor. Por esta razón, un equipo de este tipo siempre debe instalarse en la tubería aguas abajo de la bomba de calor, y se recomienda instalar una válvula de retención para evitar el flujo inverso en la ausencia de circulación del agua.

El daño a la bomba de calor causado por el incumplimiento de esta instrucción no está cubierto por la garantía.

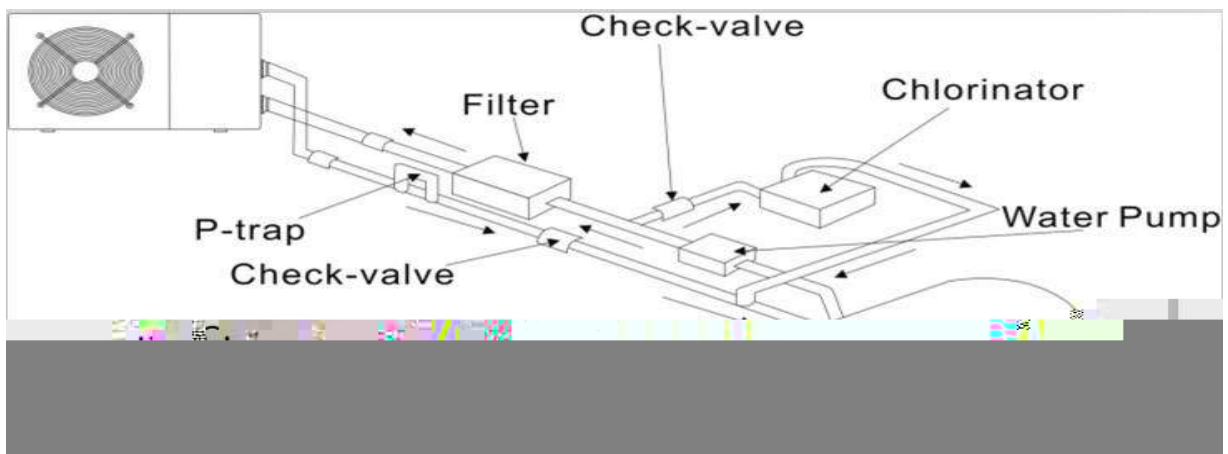

5.3 Disposición típica

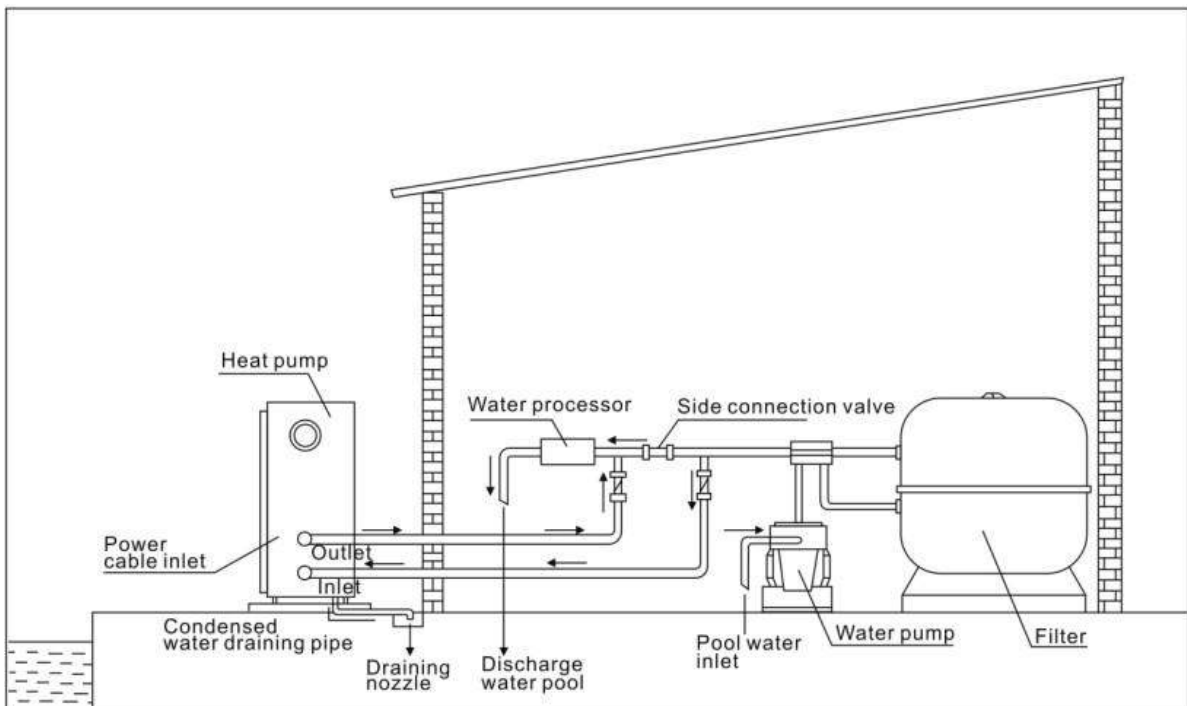

▲ NOTA

De fábrica únicamente se suministra la bomba de calor. Todos los demás componentes, incluyendo una derivación si es necesaria, deben ser proporcionados por el usuario o el instalador.

ATENCIÓN:

Con el fin de calentar el agua de la piscina (o bañera de hidromasaje), la bomba de filtración debe estar en funcionamiento para hacer que el agua circule a través de la bomba de calor. La bomba de calor no arrancará si el agua no está circulando.

5.4 Puesta en funcionamiento

Después de que todas las conexiones se hayan hecho y comprobado, llevar a cabo el siguiente procedimiento:

1. Encienda la bomba de filtración, comprobar que no haya fugas y verifique que el agua fluye desde y hacia la piscina.

2. Conecte la alimentación de la bomba de calor y pulse el botón  de encendido / apagado en el panel de control LED. La unidad se pondrá en marcha después del tiempo de retardo (ver más abajo).

3. Después de unos minutos, comprobar si el aire que impulsa hacia fuera la unidad es más frío.

4. Cuando apague la bomba de filtración, la unidad también debe apagarse de forma automática, sino, a continuación, ajuste el interruptor de flujo.

5. Permita que la bomba de calor y la bomba de filtración funcionen las 24 horas del día hasta que se alcance la temperatura deseada del agua. La bomba de calor se detendrá en este punto. Después de esto, se reiniciará automáticamente siempre que la filtración esté en funcionamiento y la temperatura del agua piscina desciende 2 grados por debajo de la temperatura establecida.

Dependiendo de la temperatura inicial del agua en la piscina y la temperatura del aire, puede tardar varios días en calentar el agua a la temperatura deseada. Una cubierta para la piscina puede reducir drásticamente el tiempo requerido.

NOTA

La unidad esta equipada con un interruptor de flujo para la protección de la BdC, con velocidad de flujo de agua adecuado . Se encenderá cuando la bomba de piscina funcione y se apagará cuando la bomba se apague.

Tiempo de retraso

A la bomba de calor se ha incorporado una temporización de la puesta en marcha de 3 minutos para proteger el circuito y evitar desgaste excesivo. La unidad se reiniciará automáticamente después de que expire el tiempo de retardo. Incluso una breve interrupción disparará este retraso de tiempo para evitar que la unidad se reinicie inmediatamente. Las interrupciones durante este período de demora no afectan a la duración de 3 minutos.

5.5 Condensación

El aire aspirado por la bomba de calor es fuertemente enfriado por la bomba de calor para calentar el agua de la piscina, este puede causar la condensación en las aletas del evaporador.

NOTA

La cantidad de condensación puede ser tanto como varios litros por hora con una humedad relativa alta.
Esto a veces es erróneamente considerado como una fuga de agua.

5.6 Manómetro (R32)

Examine el manómetro que indica la presión del gas refrigerante de la unidad, la siguiente tabla muestra el valor normal de la presión del gas (R32) cuando la máquina está apagada o encendida.

Unidad condición	Apagada			
Temp ambiente (°C)	-5~5	5~15	15~25	25~35
Temp agua (°C)	/	/	/	/
Presión manómetro (MPa)	0.59~0.85	0.85~1.18	1.18~1.59	1.59~2.1

Unidad condición	Encendida				
Temp ambiente (°C)	/	/	/	/	/
Temp agua (°C)	10~15	15~20	20~25	25~30	30~35
Presión manómetro (MPa)	1.1~1.6	1.3~1.8	1.5~2.1	1.7~2.4	1.9~2.7

6. 1 Esquema de cableado bomba de calor inverter

Ref. 71676/71677/71678/71679/71680

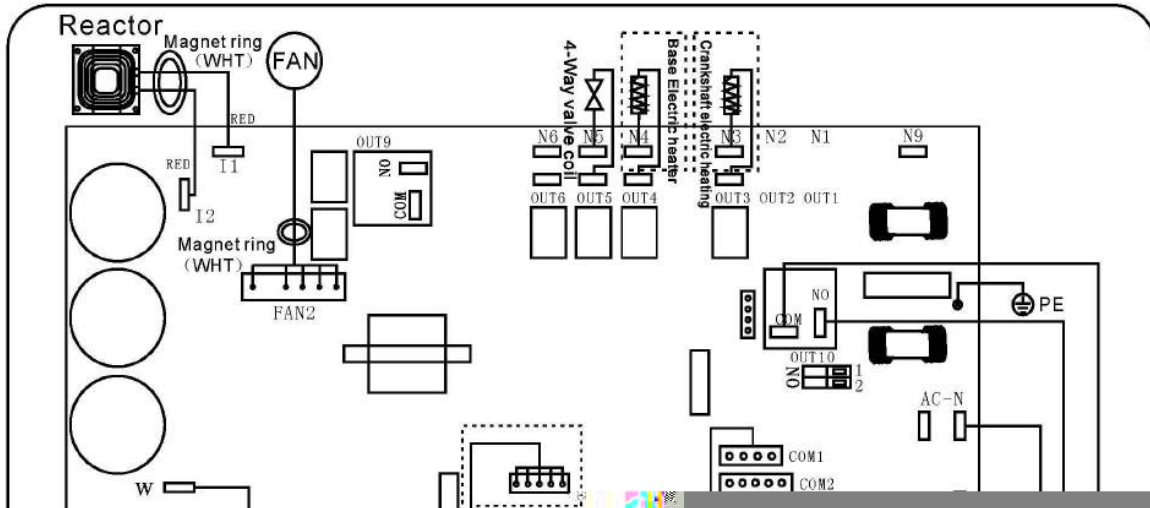

6.3 Esquema de cableado bomba de calor inverter

Ref. 71682/71683

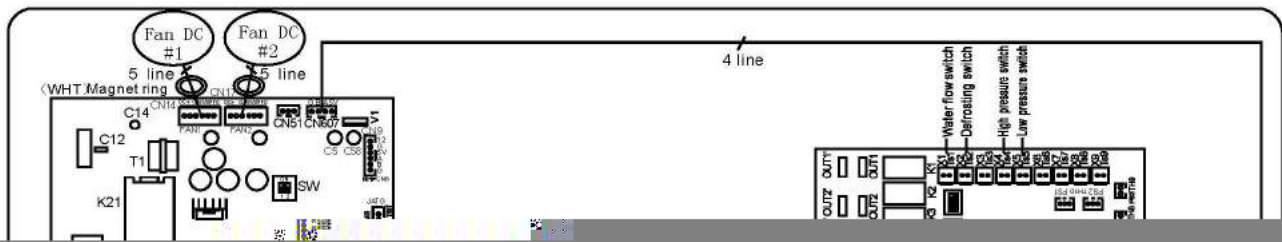

6.4 Esquema de cableado bomba de calor inverter

Ref: 68822 (R410A)

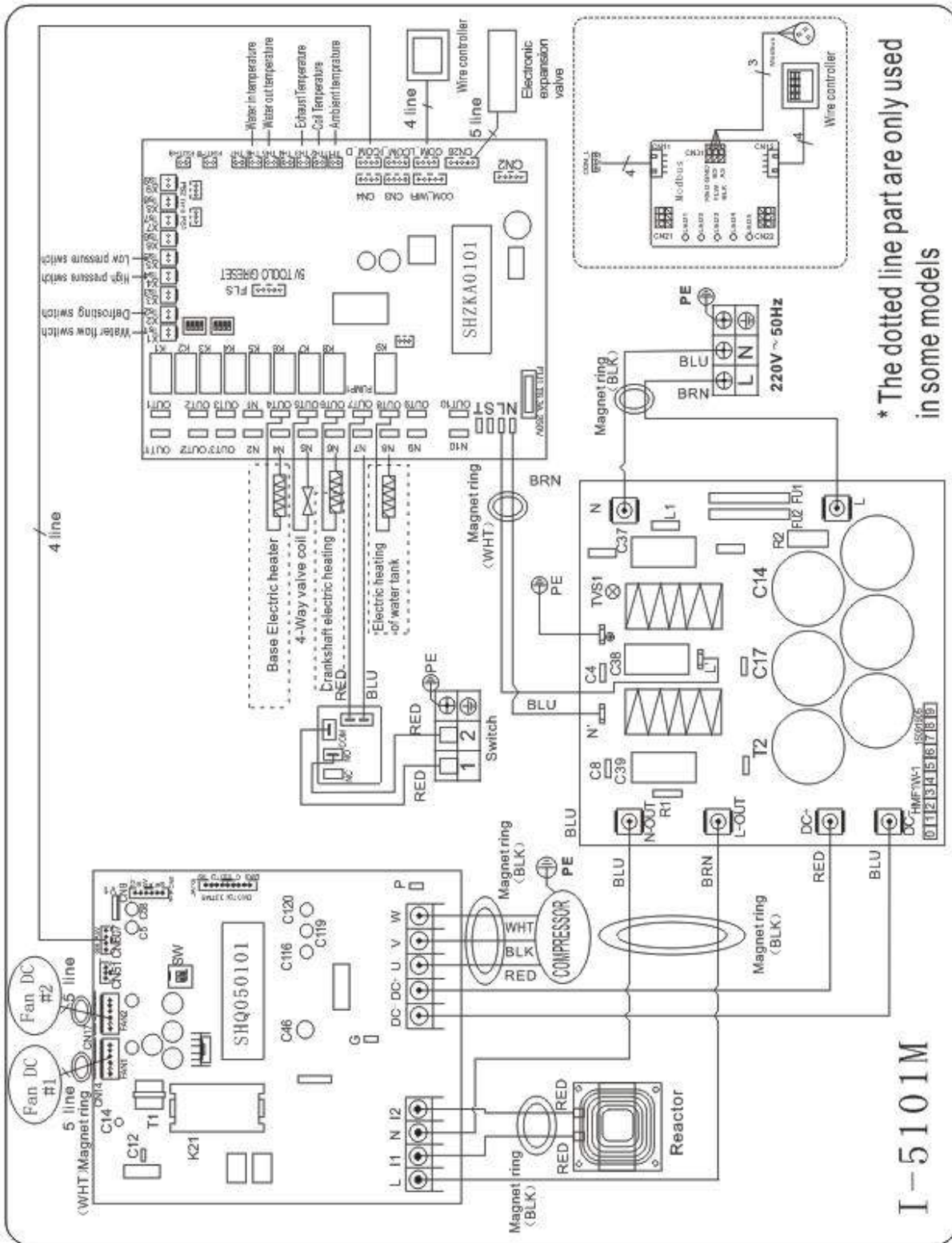

6.5 Esquema de cableado de

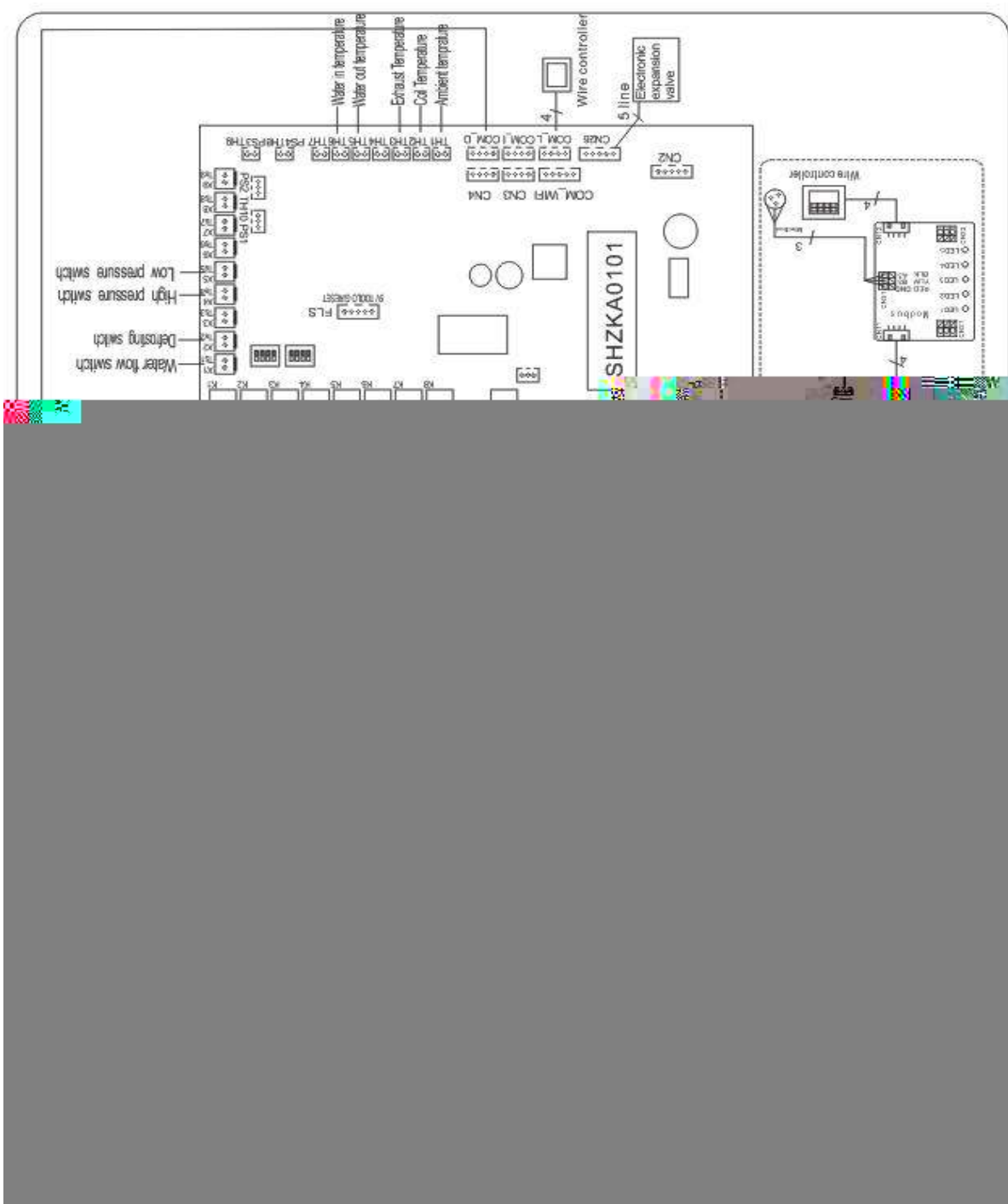

6.6 Conexión eléctrica

La fuente de alimentación para la bomba de calor debe venir, de un circuito exclusivo con componentes de protección reguladores (protección diferencial de 30 mA) y un interruptor magneto-térmico.

- La instalación eléctrica debe ser realizada por un profesional especializado (electricista) de acuerdo con las normas y regulaciones vigentes en el país de instalación.
 - El circuito de la bomba de calor debe estar conectado a un circuito de tierra de seguridad en el bloque de bornas.
 - Los cables deben estar instalados correctamente para evitar interferencias.
 - La bomba está diseñada para conectarse a una fuente de alimentación general con conexión a tierra.
 - Sección del cable; Esta sección es indicativa y debe verificarse y adaptarse de acuerdo con las necesidades y condiciones de uso.
 - La tolerancia de la variación de voltaje aceptable es +/- 10% durante la operación.
- Las conexiones se deben dimensionar según la potencia del dispositivo y el estado de instalación.

Modelos	Cortacircuitos	Longitud máxima del cable			
		2,5 mm ²	4 mm ²	6 mm ²	10 mm ²
PROELYXP07i	7 A	84 m	135 m	200 m	335 m
PROELYXP09i	9 A	57 m	90 m	130 m	225 m
PROELYXP11i	11A				
PROELYXP14i	14 A	43 m	68 m	100 m	170 m
PROELYXP16i	16 A	34 m	54 m	80 m	135 m
PROELYXP20i	20 A	29 m	45 m	66 m	110 m
PROELYXP26i	26 A	/	25 m	38 m	62 m
PROELYXP30i	35 A	/	/	22 m	36 m
PRO ELYO INVERBOOST NN 26T	9 A	15 m	35 m	49 m	81 m
PRO ELYO INVERBOOST NN 35	34 A	/	/	22 m	36 m
PRO ELYO INVERBOOST NN 35T	13 A	12 m	27 m	39 m	68 m

 Estos valores se dan como una guía, solo la intervención de un técnico autorizado puede determinar los valores correspondientes a su instalación.
La línea eléctrica debe estar equipada con una conexión a tierra y con un interruptor diferencial de 30 mA.

6.7 Instalación de la pantalla remota

Foto 1



Foto 2



Foto 3



Foto 4



Foto 5



- El lado con el enchufe se conecta con el panel de control (foto1)
- El otro lado del cable de señal. (foto2)
- Abra la tapa del cuadro de conexión eléctrica y pase a través de ella el cable de la pantalla remota. (foto3,4)
- Inserte el cableado en la posición designada en la pantalla Modbus o PCB (sin Modbus). (foto 5)

6.8 Instalación del cable de señal Modbus/Fluidra Connect

Foto 6



Foto 7



Foto 8



Foto 9

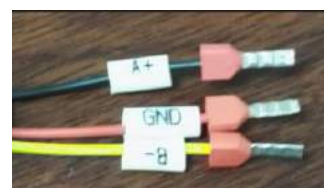

- Abra la tapa del cuadro de conexión eléctrica(Foto 6)
- Tome el cable de señal Modbus/Fluidra Connect de los accesorios (Foto7) y coloque el extremo redondo del cable de señal en el cable de señal del Modbus/Fluidra Connect Module. (Foto 8)
- Terminal de tres hilos: "A +", "B-", "GND", (Foto 9)

ATENCIÓN:

Desconectar: Un medio de desconexión (interruptor, fusible o relé) se debe colocar a la vista y ha de ser de fácil acceso desde la unidad. Esta es una práctica común en las bombas de calor comerciales y residenciales. Evita que el equipo se alimente eléctricamente de forma remota y permite desconectar la corriente en la unidad mientras está siendo reparada.

Temporizador de conexión de contacto libre de tensión Temporizador

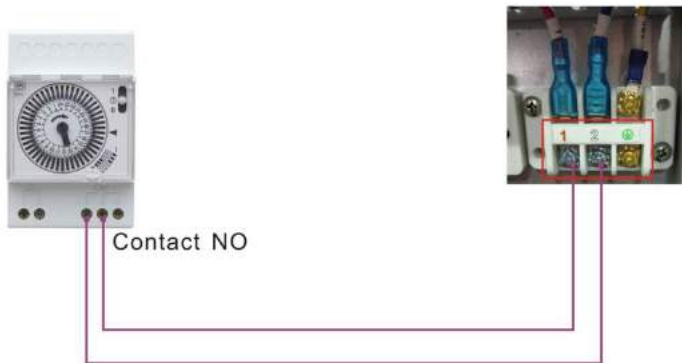

Conexión de la bomba de contacto libre de tensión

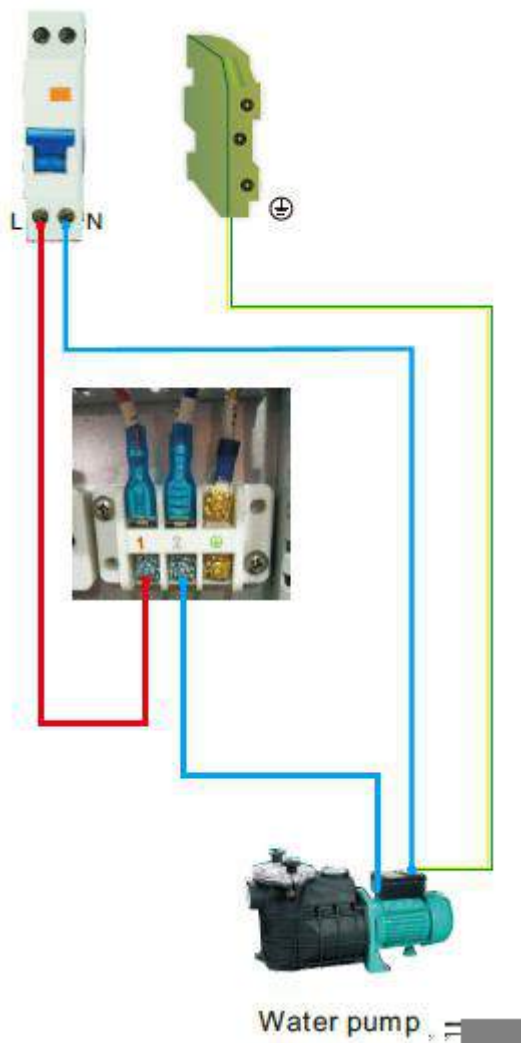

7. Funcionamiento del controlador

7.1. Guía de funcionamiento

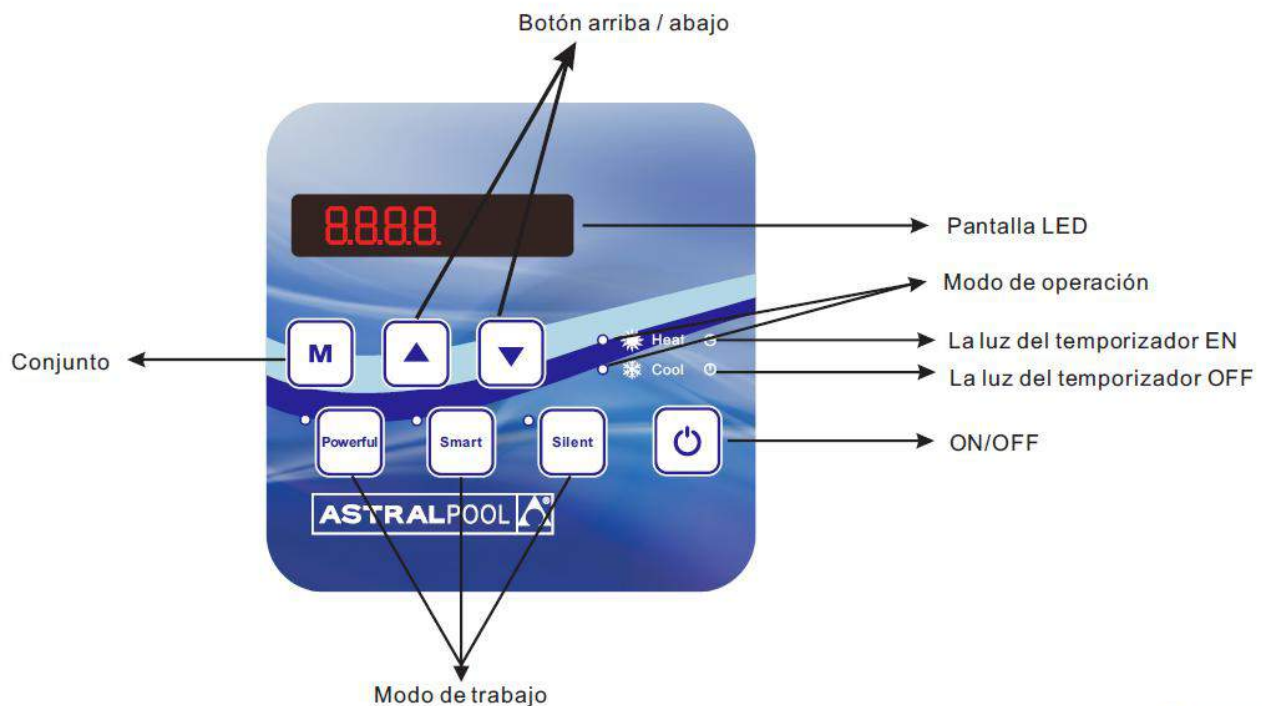



Cuando la bomba de calor se conecta a la corriente, la pantalla LED muestra un código de 3 segundos que indica el modelo de la bomba de calor.

7.2 Las claves y sus operaciones

7.2.1 Botón (icon)

Presione  para arrancar la bomba de calor, la pantalla de LED muestra la temperatura del agua deseada durante 5 segundos, luego muestra la temperatura del agua de entrada y el modo de operación.

Pulse  para detener la bomba de calor y muestre "OFF"

Aviso: Durante la comprobación y ajuste del parámetro, pulse la tecla  para salir rápidamente y guardar la configuración actual.



Pulse  de nuevo para encender / apagar la máquina.

7.2.2 Botón



 cambia el modo de calefacción y el modo automático.

7.2.3 Botón y



Bloquear / desbloquear la pantalla:

Mantenga  y  durante 5 segundos para bloquear / desbloquear la pantalla.

Ajuste de la temperatura del agua:

Pulse  o  para ajustar la temperatura del agua directamente.

Comprobación de parámetros:

Pulse  primero, luego pulse  para comprobar el parámetro User de d0 a d11

Código	Condición	Alcance	Observación
d0	IPM temperatura del molde	0-120°C	Valor de prueba real
d1	Temp. De agua de entrada T1	-9°C~99°C	Valor de prueba real
d2	Temperatura del agua de salida T2	-9°C~99°C	Valor de prueba real
d3	Temperatura ambiente. T5	-30°C~70°C	Valor de prueba real
d4	Código de limitación de frecuencia	0,1,2,4,8,16	Valor de prueba real
d5	Temperatura Evaporador T3	-30°C~70°C	Valor de prueba real
d6	Temperatura descarga de gas T6	0°C~C5°C (125°C)	Valor de prueba real
d7	Paso de EEV	0~99	N*5
d8	Frecuencia de funcionamiento del compresor	0~99Hz	Valor de prueba real
d9	Corriente del compresor	0~30A	Valor de prueba real
d10	Velocidad actual del ventilador	0-1200 (rpm)	Valor de prueba real
d11	Código de error de la última vez	Todo el código de error	
d12	MODBUS COM	0 - 5	Configuración, Sólo Modbus
d13	MODBUS ID Dirección	1 - 88	Configuración, Sólo Modbus
d14	Código del producto	1-68	Configuración, Sólo Modbus

Observación: d4: código de limitación de frecuencia,

0: sin límite de frecuencia;

1: límite de temperatura de la tubería de la bobina;

2: límite de frecuencia de sobrecalentamiento o sobreenfriamiento;

4: límite de frecuencia actual de la unidad;

8: límite de frecuencia de tensión de accionamiento;







16: límite de frecuencia de alta temperatura de conducción

Pulse  primero, luego pulse  para comprobar / ajustar el parámetro de usuario de P1 a P7

Código	Nombre	Alcance	Defecto	Observación
P0	Desescarche obligatorio	0-1	0	0: Operación normal predeterminada 1: Descongelamiento obligatorio.
P1	Modo de trabajo	0-1	1	1 Modo de calefacción, 0 modo de enfriamiento
P2	Temporizador activado / desactivado	0-1	0	1 El temporizador encendido / apagado está en función, 0 El temporizador encendido / apagado está fuera de funcionamiento (El ajuste de P5 y P6 no funcionará)
P3	Bomba de agua	0-1	0	1 Siempre en marcha, 0 Depende del funcionamiento del compresor
P4	Hora actual	HH:MM	0:00	<u>0-23:0-59</u>
P5	Temporizador en	HH:MM	0:00	<u>0-23:0-59</u>
P6	Temporizador desactivado	HH:MM	0:00	<u>0-23:0-59</u>
P7	Temp. De agua de entrada corrección	-9~9	0	Ajuste predeterminado: 0
P12	MODBUS COM	0 - 5	0	Sólo Modbus (Valor predeterminado después del restablecimiento)
P13	MODBUS ID Dirección	1 - 88	9	Sólo Modbus (Valor predeterminado después del restablecimiento)

Código con connect	Parámetro P	Descripción
71676	17FC	PAC PROELYXP07i 7-3.1Kw
71677	17FD	PAC PROELYXP09i 9-2.3Kw
71678	17FE	PAC PROELYXP11i 11-2.9Kw
71679	17FF	PAC PROELYXP14i 14-3.2Kw
71680	1800	PAC PROELYXP16i 16-3.8Kw
71681	1801	PAC PROELYXP20i 20-4.7Kw
71682	1802	PAC PROELYXP26i 26-5.9Kw
71683	1803	PAC PROELYXP30i 30-6.8Kw
68821	0CD5	PAC PROELYO INVERBOOST NN 26T 26-5.9Kw
68822	0CD6	PAC PROELYO INVERBOOST NN 35 35-8Kw
68823	0CD7	PAC PROELYO INVERBOOST NN 35T 35-8Kw

Parámetro de código de producto P Ajuste (sólo MODBUS)

Presione  +  durante 5 segundos, el primer número digital parpadeará, presione  o  para seleccionar el número de destino de 0 a F, luego presione  ir para ajustar el segundo número. Lo mismo ocurre con el tercer y cuarto número. Por último, presione  para guardar la configuración y salir, o saldrá automáticamente después de 15 segundos.

Después de la configuración, el parámetro de código de producto P no se puede restablecer, incluso si se restablece el sistema. Su valor de configuración siempre se conserva.

7.2.4 Función de restablecimiento del sistema

Presione  y  en 10s, el sistema se restablecerá y mostrará "0000" en el controlador.

7.2.5 Heat

Símbolo de calentamiento, la luz se encenderá cuando esté en funcionamiento.

Cuando se descongela, la luz parpadeará.

7.2.6 Cool

Símbolo de enfriamiento, la luz se encenderá cuando esté en funcionamiento.

7.2.7

Símbolo de parada automática, la luz se encenderá cuando esté en funcionamiento.

7.2.8

Símbolo de inicio automático, la luz se encenderá cuando esté en funcionamiento.

7.2.9

Pulse este botón, la luz parpadeará y la bomba de calor funcionará en 'Salida completa' solamente.

7.2.10 Smart

Mientras este en Smart, la bomba de calor sólo funcionará en 'Salida media' y 'Salida completa'

En 'Salida media', la luz de Smart parpadeará.

En 'Salida completa', la lámpara de Smart está encendida, la lámpara de Powerful parpadeará.

7.2.11 Silent

Mientras este en Silent, la bomba de calor solo funcionará en "salida media" y "salida pequeña"

En 'Salida pequeña', la luz de Silent parpadeará.

En 'Salida media', la lámpara de Silent está encendida, la lámpara de Smart parpadeará.

7.2.12 Auto Mode

Hay 3 modos para la unidad, solo calefacción, modo automático (calefacción y enfriamiento), solo enfriamiento.

Puede cambiar el modo solo calefacción y el modo automático presionando **M** durante 5 segundos, sin importar si la unidad está encendida o apagada.

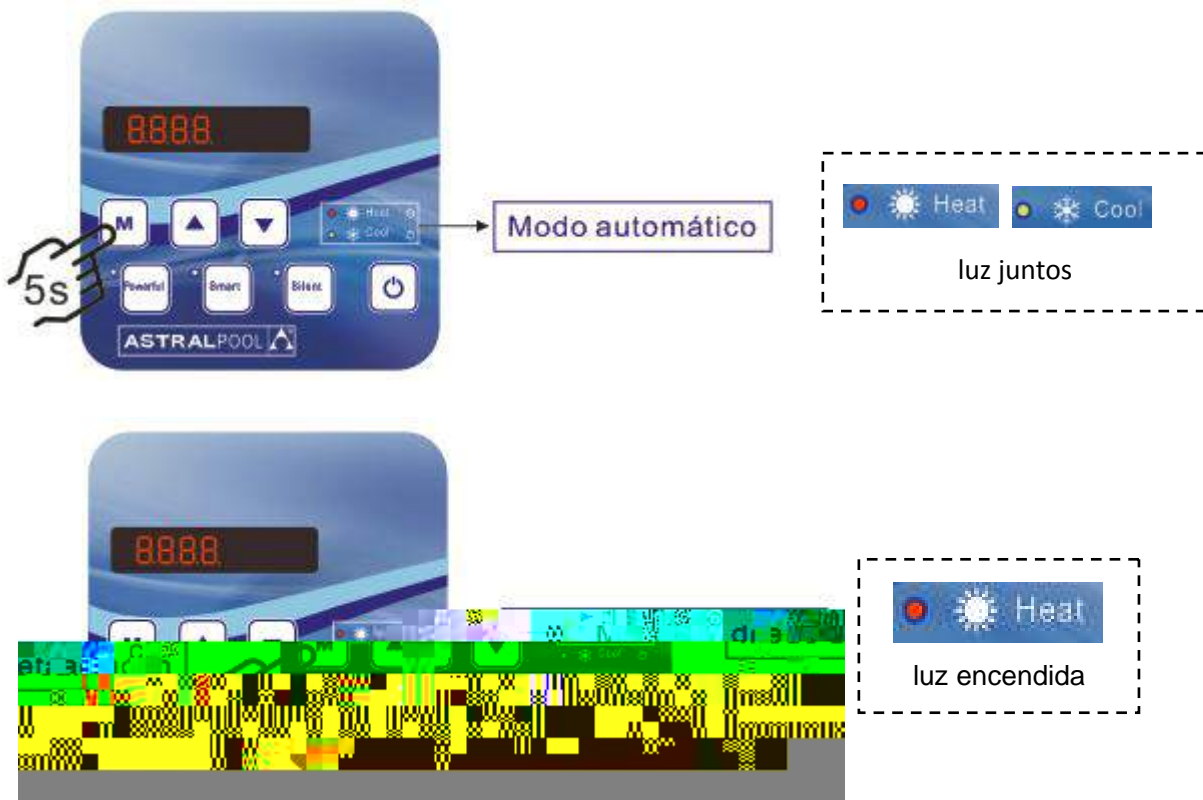

Lógica de operación del modo automatic

Compressor

La bomba de agua arranca 60 s antes del compresor, la bomba de agua arranca 30s y luego el interruptor de flujo de agua detecta caudal. Cuando el agua entra durante el tiempo de espera, la bomba de filtración se detendrá 60 segundos después de que el compresor se haya detenido. La bomba de filtración volverá a funcionar durante 3 minutos y luego se detendrá cuando el tiempo de espera tr

7.3 Lógica para calefacción

Estado de trabajo	Modo de trabajo	Agua en temperatura-T1	Por ejemplo, Agua en temperatura-T1	Bomba de calor nivel de trabajo	
1	Puesta en marcha de bomba de calor	Cuando seleccionas el "modo Smart"	$T1 < Tset-1$	$T1 < 27^{\circ}C$	Modo Powerful- frecuencia F9
2			$Tset-1 \cong T1 < Tset$	$27^{\circ}C \cong T1 < 28^{\circ}C$	Frecuencia: F9-F8-F7, ..., - F2
3			$Tset \cong T1 < Tset+ 1$	$28^{\circ}C \cong T1 < 29^{\circ}C$	Modo Silent- frecuencia F2
4			$T1 \cong Tset+1$	$T1 \cong 29^{\circ}C$	Bomba de calor estará en modo de espera y dejará de funcionar hasta que la temperatura del agua disminuya a $28^{\circ}C$.
5		Al seleccionar el "Modo Silent"	$T1 < Tset$	$T1 < 28^{\circ}C$	Modo Smart -Frecuencia F5.
6			$Tset \cong T1 < Tset+1$	$28^{\circ}C \cong T1 < 29^{\circ}C$	Modo Silent-frecuencia F2 / F1.
7			$T1 \cong Tset+1$	$T1 \cong 29^{\circ}C$	Bomba de calor estará en modo de espera y dejará de funcionar hasta que la temperatura del agua caiga a menos de $28^{\circ}C$.
8		Cuando seleccionas el "Modo Powerful"	$T1 < Tset+1$	$T1 < 29^{\circ}C$	Modo Powerfu-frecuencia F10/F9
9			$T1 \cong Tset+1$	$T1 \cong 29^{\circ}C$	Bomba de calor estará en modo de espera y dejará de funcionar hasta que la temperatura del agua disminuya a $28^{\circ}C$.
10	Reiniciar para calentar el agua en estado de espera	Cuando Bomba de calor está trabajando en "Modo Smart"	$T1 \cong Tset$	$T1 \cong 28^{\circ}C$	En espera
11			$Tset > T1 \cong Tset-1$	$28^{\circ}C > T1 \cong 27^{\circ}C$	Silent- frecuencia F2
12			$Tset-1 > T1 \cong Tset-2$	$27^{\circ}C > T1 \cong 26^{\circ}C$	Frecuencia: F2-F3-F4, ..., - F9
13		$< Tset-2$	$< 26^{\circ}C$	Powerful-frecuencia F9	
14		Cuando Bomba de calor está trabajando en "Modo Silent"	$\cong Tset$	$\cong 28^{\circ}C$	En espera
15			$Tset > T1 \cong Tset-1$	$28^{\circ}C > T1 \cong 27^{\circ}C$	Modo Silent-frecuencia F2 / F1
16		$T1 < Tset-1$	$T1 < 27^{\circ}C$	Smart-frecuencia F5	
17	Cuando Bomba de calor está trabajando en "Modo Powerful"	$T1 < Tset-1$	$T1 < 27^{\circ}C$	Powerful -frecuencia F10 / F9	

7.4 Lógica de operación de enfriamiento

Estado de trabajo		Modo de trabajo	Agua en temperatura-T1	Por ejemplo, Agua en temperatura-T1	Bomba de calor nivel de trabajo
1	Puesta en marcha de bomba de calor	Cuando seleccionas el "Modo Smart"	$T1 \cong Tset-1$	$T1 \cong 27^{\circ}C$	En espera
2			$Tset-1 < T1 \cong Tset$	$27^{\circ}C < T1 \cong 28^{\circ}C$	Modo Silent-frecuencia F2
3			$Tset < T1 \cong Tset+1$	$28 < T1 \cong 29^{\circ}C$	Frecuencia: F9 -F8-F7,...,- F2
4			$T1 \cong Tset+1$	$T1 \cong 29^{\circ}C$	Modo Powerful-F9
5		Al seleccionar el "Modo Silent"	$T1 \cong Tset-1$	$\cong 27^{\circ}C$	En espera
6			$Tset-1 < T1 \cong Tset$	$27^{\circ}C < T1 \cong 28^{\circ}C$	Modo Silent- frecuencia F2/F1
7			$T1 > Tset$	$T1 > 28^{\circ}C$	Modo Smart -frecuencia F5
8	Cuando seleccionas el "Modo Powerful"	$T1 > Tset-1$	$T1 > 27^{\circ}C$	Modo Powerful-frecuencia F10/F9	
9		$T1 \cong Tset-1$	$T1 \cong 27^{\circ}C$	En espera	
10	Reiniciar para enfriar el agua en estado de espera	Smart	$T1 \cong Tset-1$	$T1 \cong 27^{\circ}C$	En espera
11			$Tset \cong T1 < Tset+1$	$28 \cong T1 < 29^{\circ}C$	Modo Silent- frecuencia F2
12			$Tset+1 \cong T1 < Tset+2$	$29 \cong T1 < 30^{\circ}C$	Frecuencia: F2 -F3-F4,...,- F9
13			$T1 \cong Tset+2$	$T1 \cong 30^{\circ}C$	Modo Powerful -frecuencia F9
14		Silent	$Tset < T1 \cong Tset+1$	$28 < T1 \cong 29^{\circ}C$	Modo Silent-frecuencia F2/F1
15			$T1 > Tset+1$	$T1 > 29^{\circ}C$	Modo Smart-frecuencia F5
16		Powerful	$T1 > Tset+1$	$T1 > 29^{\circ}C$	Modo Powerful-frecuencia F10/F9
17	$T1 \cong Tset-1$		$T1 \cong 27^{\circ}C$	En espera	

8.1 Visualización del código de error en el controlador LED

Mal funcionamiento	Código de error	Razón	Solución
Fallo en el sensor de temperatura de entrada del agua T1-TH6	PP01	1. El sensor en circuito abierto o cortocircuito 2. El cableado del sensor está suelto	1. Verifique o cambie el sensor 2. Reparar el cableado de los sensores
Fallo en el sensor de temperatura de salida del agua T2	PP02	1. El sensor en circuito abierto o cortocircuito 2. El cableado del sensor está suelto	1. Verifique o cambie el sensor 2. Reparar el cableado de los sensores
Fallo en la sonda del evaporador. T3-TH2	PP03	1. El sensor en circuito abierto o cortocircuito 2. El cableado del sensor está suelto	1. Verifique o cambie el sensor 2. Reparar el cableado de los sensores
Fallo del sensor de aspiración del compresor.	PP04	1. El sensor en circuito abierto o cortocircuito 2. El cableado del sensor está suelto	1. Verifique o cambie el sensor 2. Reparar el cableado de los sensores
Falla del sensor de temperatura ambiental T5-TH1	PP05	1. El sensor en circuito abierto o cortocircuito 2. El cableado del sensor está suelto	1. Verifique o cambie el sensor 2. Reparar el cableado de los sensores
Fallo del sensor de temperatura de descarga del compresor T6-TH3	PP06	1. El sensor en circuito abierto o cortocircuito 2. El cableado del sensor está suelto	1. Verifique o cambie el sensor 2. Reparar el cableado de los sensores
Protección antihielo en invierno	PP07	La temperatura ambiente o la temperatura de entrada del agua es demasiado baja	Protección normal
Protección de baja temperatura ambiente	PP08	1. El entorno está más allá del alcance de uso. 2. Anormalidad del sensor	1. Dejar de usar, más allá del alcance de uso 2. Cambie el sensor
Protección contra temperatura del condensador. Demasiado alta en modo enfriar. T3-TH2	PP10	1. La temperatura del ambiente es demasiado alta o la temperatura del agua es demasiado alta en el modo de enfriamiento 2. El sistema de refrigeración es anormal	1. Compruebe el alcance de USO 2. Revise el sistema de refrigeración
Protección de temperatura de agua. Muy baja en modo frío T2-TH5	PP11	1. Bajo flujo de agua 2. Sensor de temperatura T2-TH5 anormal	1. Revisar la bomba de agua y el circuito de agua 2. Cambie el sensor de temperatura T2-TH5

Mal funcionamiento	Código de error	Razón	Solución
Fallo de alta presión TS4	EE01	<ol style="list-style-type: none"> 1. Minipresostato de alta presión mal conectado o falla 2. La temperatura ambiente es demasiado alta 3. La temperatura del agua es demasiado alta 4. El flujo de agua es demasiado bajo 5. La velocidad del motor del ventilador es anormal o el motor del ventilador está dañado 	<ol style="list-style-type: none"> 1. Compruebe el cableado del minipresostato de alta presión o cambielo 2. Revise el flujo de agua o la bomba de agua 3. Compruebe el motor del ventilador 4. Revisar y reparar el sistema de tuberías
Fallo de baja presión TS5	EE02	<ol style="list-style-type: none"> 1. Minipresostato de baja presión mal conectado o falla 2. EEV está bloqueada o el sistema de tuberías está atascado 3. La velocidad del motor es anormal o el motor está dañado 4. Fuga de gas 	<ol style="list-style-type: none"> 1. Compruebe el cableado del minipresostato de baja presión o cambielo 2. Compruebe la EEV y el sistema de tuberías. Compruebe el motor. 3. Mediante el manómetro de alta presión comprobar el valor de la presión 4. Comprobar el sistema de refrigeración
No hay flujo de agua o fallo del interruptor de flujo de agua TS1	EE03 Or" ON"	<ol style="list-style-type: none"> 1. El interruptor de flujo de agua está mal conectado o dañado 2. No / Insuficiente flujo de agua. 	<ol style="list-style-type: none"> 1. Comprobar el cableado del interruptor de flujo de agua o cambiarlo. 2. Compruebe la bomba de filtración o el circuito de agua
Protección de temperatura del agua demasiado alta en modo calentar T2-TH5	EE04	<ol style="list-style-type: none"> 1. Bajo flujo de agua 2. El interruptor de flujo de agua está atascado y el suministro de agua está cortado 3. Sensor T2-TH5 es anormal 	<ol style="list-style-type: none"> 1. Compruebe el circuito de agua 2. Compruebe la bomba de filtración o el interruptor de flujo de agua 3. Compruebe el sensor T2-TH5 o cambielo
Temperatura de descarga del compresor demasiado alta T6-TH3	EE05	<ol style="list-style-type: none"> 1. Falta de gas 2. Bajo flujo de agua 3. Falla el sensor T6-TH3 4. Sistema de tubería esta bloqueado 	<ol style="list-style-type: none"> 1. Compruebe el manómetro de alta presión, si es demasiado bajo, llénelo con un poco de gas 2. Compruebe el circuito de agua y la bomba de filtración 3. Compruebe el sistema de tuberías si hubiera algún bloqueo 4. Cambiar el sensor T6-TH3

Mal funcionamiento	Código de error	Razón	Solución
Fallo de controlador o fallo de comunicación	EE06	<ol style="list-style-type: none"> 1. La conexión de cable no es buena, o el cable de señal esta dañado 2. Falla el controlador 	<ol style="list-style-type: none"> 1.Compruebe y vuelva a conectar el cable de señal 2.Cambiar el cable de señal 3. Apague el suministro eléctrico y reinicie la máquina 4. Cambiar el controlador
Protección de consumo del compresor	EE07	<ol style="list-style-type: none"> 1. La corriente del compresor es demasiado grande instantáneamente 2. Mala conexión para la secuencia de la fase del compresor 3. La acumulación de aceite o líquido en el compresor hace que la corriente aumente. 4. Compresor o placa de control dañada 5. El flujo de agua es anormal 6. Fluctuaciones en la energía en un corto periodo de tiempo. 	<ol style="list-style-type: none"> 1.Compruebe el compresor y las fases 2.Compruebe el circuito de agua y la bomba de filtración. 3.Compruebe si la potencia en el rango normal 4.Compruebe la conexión de secuencia de fases 5. Comprobar la entrada de energía principal.
Error de comunicación entre el controlador y la placa principal	EE08	<ol style="list-style-type: none"> 1. Conexión de cable de señal débil o cable de señal dañado 2. Mal funcionamiento del controlador 	<ol style="list-style-type: none"> 1.Compruebe y vuelva a conectar el cable de señal 2.Cambiar el cable de señal 3.Apague el suministro eléctrico y reinicie la máquina 4.Cambiar el controlador
Error de comunicación entre la placa principal y la placa del controlador	EE09	<ol style="list-style-type: none"> 1. Conexión de cable de comunicaciones débil 2. El cable está dañado 	<ol style="list-style-type: none"> 1.Compruebe la conexión del cable 2.Cambiar el cable
Protección VDC. Tensión demasiado alta	EE10	<ol style="list-style-type: none"> 1. La tensión de la línea madre es demasiado alta 2. Controlador está dañado. 	<ol style="list-style-type: none"> 1.Compruebe si la potencia está en el rango normal 2.Cambie el controlador
Protección del módulo IPM	EE11	<ol style="list-style-type: none"> 1. Error de datos 2. Conexión de fase del compresor incorrecta 3. La acumulación de aceite o líquido en el compresor hace que la corriente aumente. 4. Compresor o controlador dañado 	<ol style="list-style-type: none"> 1.Error en

Mal funcionamiento	Código de error	Razón	Solución
Protección de bajo voltaje de VDC	EE12	<ol style="list-style-type: none"> 1. La tensión de la línea madre es demasiado baja 2. El controlador está dañado. 	<ol style="list-style-type: none"> 1. Compruebe si la potencia está en el rango normal 2. Cambiar la placa de control
Protección de sobreintensidad	EE13	<ol style="list-style-type: none"> 1. La corriente del compresor es demasiado grande momentánea 2. El flujo de agua es anormal 3. Fluctuaciones de energía en un corto espacio de tiempo 4. Inductor PFC incorrecto 	<ol style="list-style-type: none"> 1. Compruebe el compresor 2. Compruebe el circuito de agua 3. Compruebe si la potencia está en el rango normal 4. Compruebe si se utiliza el inductor PFC correcto
Error de salida del circuito de detección de temperatura del módulo IPM	EE14	<ol style="list-style-type: none"> 1. Salida anormal del circuito térmico del módulo IPM 2. El motor del ventilador es anormal o dañado 3. La hoja de ventilador está rota 	<ol style="list-style-type: none"> 1. Cambiar el controlador 2. Compruebe si la velocidad del motor es demasiado baja o si el motor del ventilador está dañado, cambielo 3. Cambiar otra hoja de ventilador
Temperatura del módulo IPM demasiado alta	EE15	<ol style="list-style-type: none"> 1. Excepción de salida del circuito térmico del módulo IPM 2. Motor es anormal o dañado 3. La hoja de ventilador está rota 	<ol style="list-style-type: none"> 1. Cambiar una tarjeta de conductor 2. Compruebe si la velocidad del motor del ventilador es demasiado baja o si el motor del ventilador está dañado, cambielo 3. Cambiar la hoja de ventilador
Protección del módulo PFC	EE16	<ol style="list-style-type: none"> 1. Excepción de salida del módulo PFC 2. El motor es anormal o dañado 3. La hoja del ventilador está rota 4. Salto de voltaje de entrada, la potencia de entrada es anormal 	<ol style="list-style-type: none"> 1. Cambiar el controlador 2. Compruebe si la velocidad del motor es demasiado baja o si el motor del ventilador está dañado, cambielo 3. Cambiar la hoja del ventilador 4. Comprobar la tensión de entrada
Fallo motor del ventilador DC	EE17	<ol style="list-style-type: none"> 1. El motor DC está dañado 2. El controlador está dañado 3. La hoja del ventilador está atascada 	<ol style="list-style-type: none"> 1. Localice el motor DC, sustituya por uno nuevo. 2. Cambiar el controlador 3. Encuentre el obstáculo y elimínelo.
Función anormal del módulo PFC	EE18	La placa de control está dañada	<ol style="list-style-type: none"> 1. Cambiar el controlador 2. Compruebe si la velocidad del motor del ventilador es demasiado baja o si el motor del ventilador está dañado, cambielo

Mal funcionamiento	Código de error	Razón	Solución
Fallo por alta temperatura del modulo PFC	EE19	<ol style="list-style-type: none"> 1. Salida del circuito térmico del módulo PFC anormal 2. El motor es anormal o dañado 3. La hoja del ventilador está rota 4. El tornillo en la placa de control no está apretado 	<ol style="list-style-type: none"> 1. Cambiar el controlador 2. Compruebe si la velocidad del motor es demasiado baja o si el motor del ventilador está dañado, cámbielo 3. Cambiar la hoja del ventilador 4. Verifique si el tornillo está suelto
Error de alimentación de entrada	EE20	El voltaje de la fuente de alimentación fluctúa demasiado	Compruebe si el voltaje es estable
Error en el control del software	EE21	<ol style="list-style-type: none"> 1. El compresor funciona fuera de ritmo 2. Programa incorrecto 3. Las impurezas dentro del compresor hace que la velocidad de rotación sea inestable 	<ol style="list-style-type: none"> 1. Compruebe o cambie el controlador 2. Introduzca el programa correcto
Error de circuito de detección de corriente	EE22	<ol style="list-style-type: none"> 1. Señal de tensión anormal 2. El controlador está dañado 	<ol style="list-style-type: none"> 1. Compruebe o cambie el controlador
Fallo de arranque del compresor	EE23	<ol style="list-style-type: none"> 1. El controlador está dañado 2. Error de cableado del compresor o contacto deficiente o desconectado 3. Acumulación de líquido dentro 4. Conexión de fase incorrecta para el compresor 	<ol style="list-style-type: none"> 1. Compruebe o cambie el controlador 2. Compruebe el cableado del compresor de acuerdo con el diagrama de circuito <p>Compruebe el compresor o cámbielo</p>
Fallo del dispositivo de temperatura ambiente en la placa electrónica	EE24	Fallo del dispositivo de temperatura ambiente	Cambiar la placa del controlador o la placa principal
Falla de fase del compresor	EE25	Mala conexión de las fases U, V, W.	Compruebe el cableado actual de acuerdo con el diagrama de circuito
Error en la válvula de 4 vías	EE26	<ol style="list-style-type: none"> 1. Fallo de la válvula de cuatro vías 2. Falta de refrigerante (no detecta cuando falla T3-TH2 o T5-TH1) 	<ol style="list-style-type: none"> 1. Conmutar al modo de refrigeración para comprobar si la válvula de 4 vías se ha invertido correctamente 2. Cambiar la válvula de 4 vías 3. Llenar con gas
Error de lectura de datos EEPROM	EE27	<ol style="list-style-type: none"> 1. Datos de la EPROM incorrectos en el programa o fallo en la entrada de datos de la EPROM 2. Fallo de la placa principal 	<ol style="list-style-type: none"> 1. Introduzca los datos correctos de la EEPROM 2. Cambiar la placa principal
Falla de comunicación en el chip interno de la placa electrónica	EE28	Fallo en la placa principal	<ol style="list-style-type: none"> 1. Apague el suministro eléctrico y vuelva a encenderlo 2. Cambiar la placa principal

Observaciones:

1. En el modo de calefacción, si la temperatura de salida del agua es más alta que la temperatura establecida , en más de 7°C,, el controlador LED muestra EE04 para la protección del sobrecalentamiento del agua.
2. En el modo de enfriamiento, si la temperatura de salida del agua es más baja que la temperatura establecida , en más de 7°C, el controlador LED muestra PP11 para la protección de sobrecalentamiento del agua.

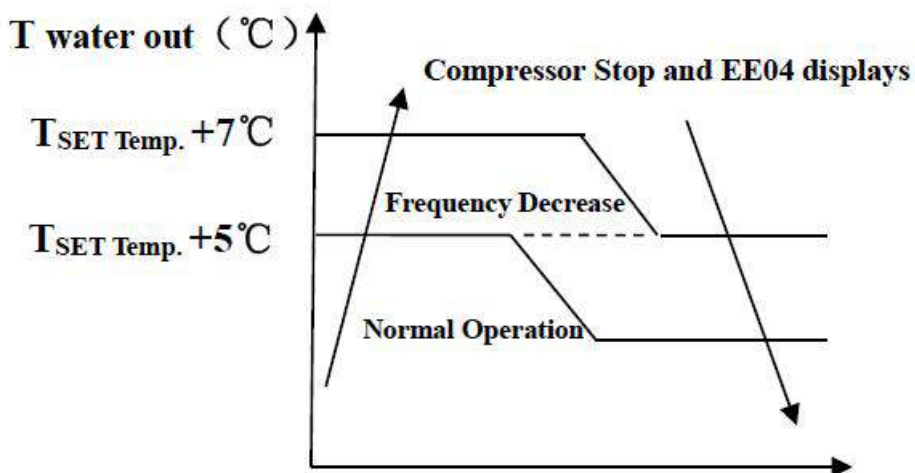

Protección contra sobrecalentamiento de agua EE04

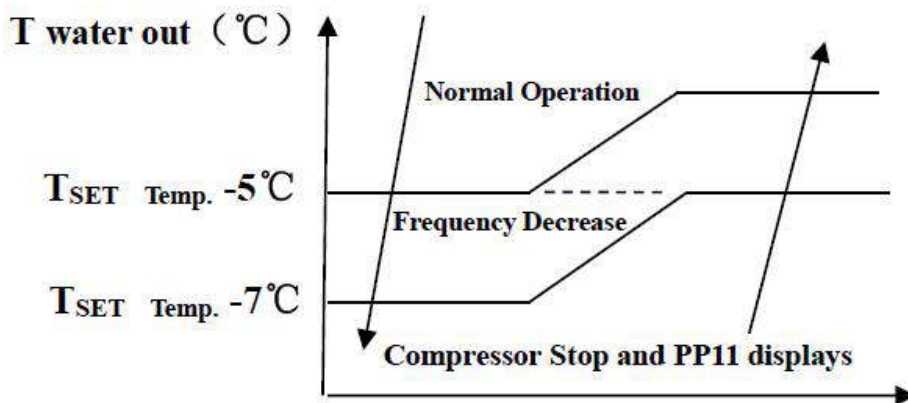

Protección de sobreenfriamiento de agua PP11

Por ejemplo, como a continuación:

Modo	Temperatura salida del agua	Temperatura Set Point	Condición	Mal funcionamiento
Modo de calentamiento	36°C	29°C	$T_{out} - T_{set} \cong 7^{\circ}\text{C}$	EE04 Protección contra sobrecalentamiento para la temperatura del agua (T2)
Modo de enfriamiento	23°C	30°C	$T_{set} - T_{out} \cong 7^{\circ}\text{C}$	PP11 Protección demasiado baja para la temperatura del agua (T2)

8.2 Otras Averías y Soluciones (No display en controlador LED)

Aavería	Descripción	Motivos	Solución
La bomba de calor no está funcionando	Ninguna visualización en el display del controlador LED.	No hay alimentación de potencia.	Chequee el cable e interruptor, verifique si están conectados.
	Controlador LED muestra el tiempo actual	La bomba de calor está en el estado standby.	Inicie la bomba de calor para su puesta en marcha.
	El controlador LED muestra la temperatura del agua actual.	<ol style="list-style-type: none"> 1. La temperatura del agua está llegando al valor de ajuste, la bomba de calor se encuentra en estado de temperatura constante. 2. La bomba de calor comienza justo a funcionar. 3. Bajo descongelación. 	<ol style="list-style-type: none"> 1. Verifica el ajuste de la temperatura del agua. 2. Inicie la bomba de calor después de algunos minutos. 3. El controlador LED debe mostrar "descongelación".
La temperatura del agua se enfría cuando la bomba de calor funciona en el modo calefacción.	El controlador LED muestra la temperature actual del agua y el código de error.	<ol style="list-style-type: none"> 1. Elección del modo incorrecto. 2. Las cifras muestran un problema. 3. Fallo del controlador. 	<ol style="list-style-type: none"> 1. Ajuste el modo para un buen funcionamiento. 2. Reemplace el controlador LED de fallo, y luego chequee el estado después de haber cambiado el modo de funcionamiento, verifique la temperatura de entrada y salida del agua. 3. Reemplace o repare la unidad de la bomba de calor.
Funcionamiento corto	LED muestra la temperature actual del agua, no se muestra el código de error.	<ol style="list-style-type: none"> 1. Ventilador NO funciona. 2. La ventilación del aire no es suficiente. 3. El refrigerante no es suficiente. 	<ol style="list-style-type: none"> 1. Chequee las conexiones de cable entre el motor y el ventilador, si es necesario, deben ser reemplazados. 2. Compruebe la ubicación de la unidad de la bomba de calor, y elimine todos los obstáculos para tener una buena ventilación del aire. 3. Reemplace o repare la unidad de la bomba del calor.
Manchas de agua	Manchas de agua en la unidad de la bomba de calor	<ol style="list-style-type: none"> 1. Protección 2. Fuga del agua. 	<ol style="list-style-type: none"> 1. Ninguna acción. 2. Verifique con cuidado el intercambiador de calor de titanio si hay algún fallo de fuga.
Demasiado hielo en el evaporador	Demasiado hielo en el evaporador		<ol style="list-style-type: none"> 1. Chequee la ubicación de la unidad de la bomba de calor, y elimine todos los obstáculos para tener una buena ventilación del aire. 2. Reemplace o repare la unidad de la bomba de calor.

9.1 Diagrama de despiece

Modelo: 71676

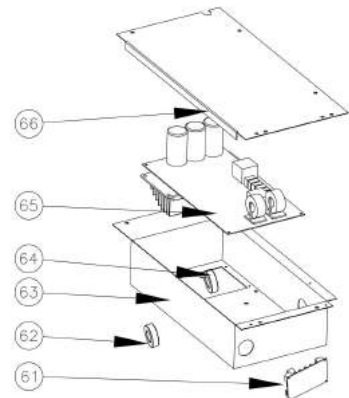
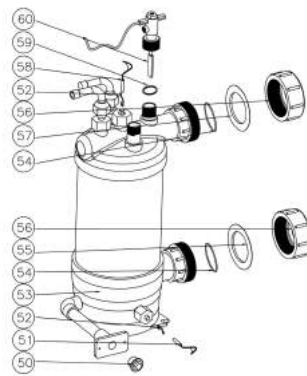
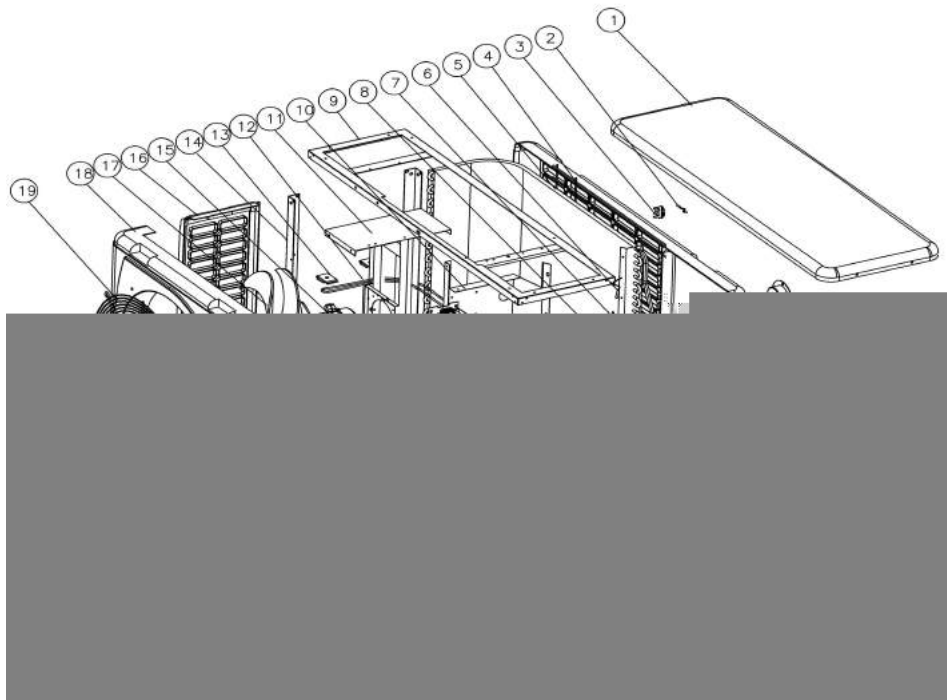

9.2 Lista de piezas de repuesto Modelo : 71676

NO	ERP	Nombre de las partes	NO	ERP	Nombre de las partes
1	1330900291	Tapa superior	34	117020180	Controlador
2	117110020	Sonda Tª ambiente T5-TH1	35	103000227	Tubería evaporador
3	133020010	Clip sonda Tª ambiente	36	136020018	Bloque de goma
4	1330900271	Panel trasero	37	103000227	Tubería de distribución
5	103000227	Evaporador	38	106000011	Manómetro
6	117110004	Sonda evaporador. Desescarche. T3-TH2	39	113020320	Tubería de retorno de gas
7	113190001	Clip	40	113080074	EEV a tuberías de distribución
8	113190001	Alojamiento de sonda	41	113070042	Intercambiador a EEV
9	108110038	Marco superior	42	119000017	EEV
10	108050073	Panel de aislamiento	43	116000071	Minipresostato de baja presión
11	108110043	Soporte del motor del ventilador	44	117110021	Sonda Tª descarga sensor T6-TH3
12	142000058	Resistencia de calentamiento del evaporador	45	113010229	Tubo de escape
13	108480015	Fijación de resistencia evaporador	46	113030081	Válvula de 4 vías para intercambiador.
14	108110004	Pilar	47	116000066	Minipresostato de alta presión
15	112000031	Motor del ventilador	48	113060123	Tubo
16	1330900261	Panel lateral izquierdo	49	121000006	Válvula de 4 vías
17	132000015	Aspa del ventilador	50	150000110	Tapón de drenaje
18	1330900251	Panel frontal	51	117110012	Sonda Tª de entrada de agua. sensor T1-TH6
19	108010014	Rejilla ventilador	52	108010025	Clip del sensor de temperatura del intercambiador
20	117230003	Reactor	53	102040705	Intercambiador de calor de titanio
21	101000187	Compresor + bases antivibratorias.	54	133020026	Junta de goma en la conexión de agua
22	142000072	Resistencia de calentamiento del compresor	55	133020011	Anillo de goma azul
23	101000187	Compresor + bases antivibratorias.	56	113900082	Conjuntos de conexión de agua
24	113100008	Chapa sujeción válvula de globo	57	133020011	Anillo de goma rojo
25	120000091	Válvula de globo	58	117110011	Sonda Tª salida de agua sensor T2-TH5
26	180140064	Bandeja de base	59	116000001	Junta de estanqueidad interruptor de flujo de agua
27	108010065	Chapa bornas de conexión.	60	112100021-1	Interruptor de flujo de agua
28	115000004	Bornas de conexión	61	117010095	Modulos modbus
29	113100009	Presilla para cables de conexión	62	117240002	Anillo magnético
30	1330900281	Panel derecho	63	108110057	Caja electrica
31	1332500051	Tapa de plástico de caja de conexión.	64	117240003	Anillo magnético
32	108010018	Caja de controlador	65	117100046	PCB
33	113712007	Caja de control impermeable	66	108050017	Tapa de caja electrica

9.3 Modelo: 71677/71678/71679

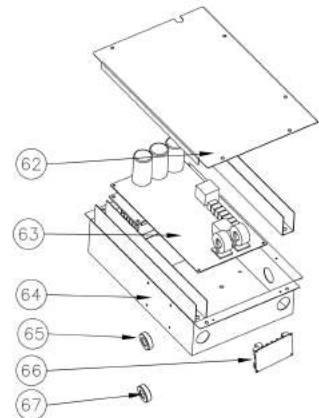
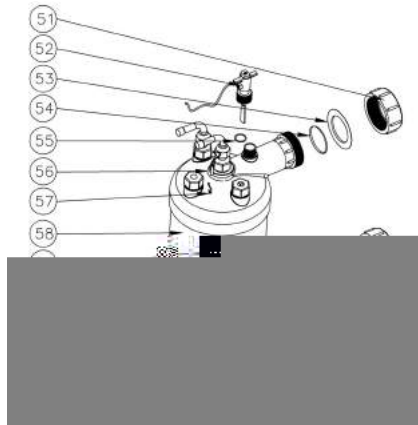
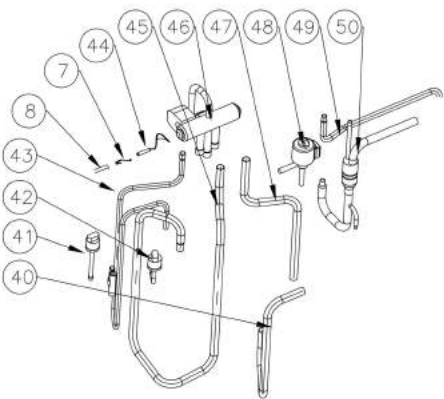
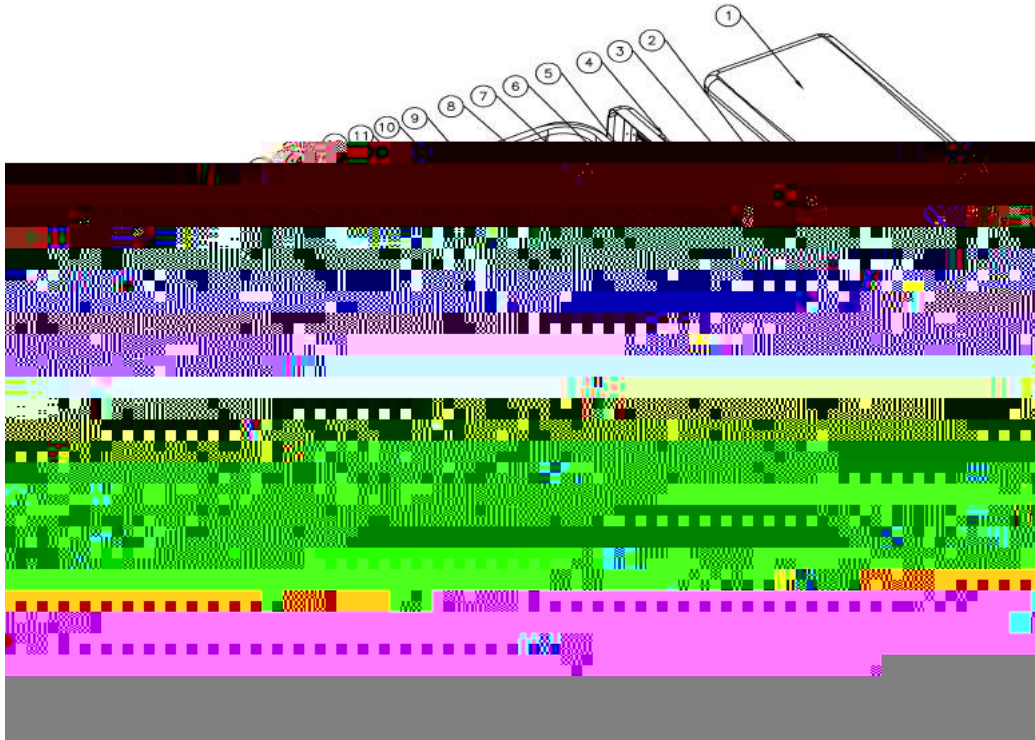

9.4 Lista de piezas de repuesto/ Modelo: 71677

NO	ERP	Nombre de las partes	NO	ERP	Nombre de las partes
1	1330900291	Tapa superior	35	113712007	Caja de control impermeable
2	117110020	Sonda de Temperatura ambiente, T5-TH1	36	117020180	Controlador
3	133020010	Clip sonda Tª ambiente	37	103000221	Tubería evaporador
4	1330900271	Panel Trasero	38	136020005	Bloque de goma
5	103000221	Evaporador	39	103000221	Tubería de distribución
6	117110004	Sonda evaporador. Desescarche. T3-TH2	40	113030086	Válvula de 4 vías al intercambiador
7	113100009	Clip	41	116000066	Minipresostato de alta presión
8	113100009	Alojamiento sonda	42	116000071	Minipresostato de baja presión
9	108110038	Marco superior	43	113010210	Tubo de escape
10	108110043	Soporte del motor del ventilador	44	117110021	Sonda de Tª descarga, T6-TH3
11	117230003	Reactor	45	113020322	Tubería de retorno de gas
12	108480015	Fijación de resistencia evaporador	46	121000006	Válvula de 4 vías
13	108110004	Pilar	47	113060084	Válvula de 4 vías para tuberías colectivas
14	142000079	Resistencia de calentamiento del evaporador	48	119000017	EEV
15	112000031	Motor del ventilador	49	113080054	EEV a la tubería de distribución
16	1330900261	Panel lateral izquierdo	50	113070044	Intercambiador a EEV
17	108010024	Tapa del eje del ventilador	51	113900082	Conjuntos de conexión de agua
18	132000015	Aspa del ventilador	52	112100021-1	Interruptor de flujo de agua
19	1330900251	Panel frontal	53	133020012	Anillo de goma roja
20	108010014	Rejilla ventilador	54	133020026	Junta de goma en la conexión de agua
21	108050073	Panel de aislamiento	55	136020083	Junta de estanqueidad interruptor de flujo de agua.
22	113100008	Tubo de cobre	56	117110011	Sonda de Tª salida agua, T2-TH5
23	120000091	Válvula de globo	57	108010025	Clip del sensor de temperatura del intercambiador
24	142000074	Resistencia de calentamiento del compresor	58	102040748	Intercambiador de calor de titanio
25	101000188	Compresor + bases antivibratorias.	59	133020011	Anillo de goma azul
26	101000188	Compresor + bases antivibratorias.	60	117110012	Sonda de Temperatura entrada agua , T1-TH6
27	108110066	Bandeja de base	61	150000110	Tapón de drenaje
28	108010065	Chapa bornas de conexión	62	108050017	Tapa de la caja eléctrica
29	133090028	Panel derecho	63	117100046	PCB
30	106000011	Manómetro	64	108110031	Caja electrica
31	136010004	Presilla para cables de conexión	65	117240002	Anillo magnético
32	115000004	Bornas de conexión	66	117010095	Módulo Modbus
33	1332500051	Tapa de plástico de caja de conexión	67	117240003	Anillo magnético
34	133030011	Caja de controlador			

9.5 Lista de piezas de repuesto/ Modelo: 71678

NO	ERP	Nombre de las partes	NO	ERP	Nombre de las partes
1	1330900291	Tapa superior	35	113712007	Caja de control impermeable
2	117110020	Sonda Tª ambiente T5-TH1	36	117020180	Controlador
3	133020010	Clip sonda Tª ambiente	37	103000182	Tubería evaporador
4	1330900271	Panel trasero	38	136020005	Bloque de goma
5	103000182	Evaporador	39	103000182	Tubería de distribución
6	117110004	Sonda evaporador. Desescarche. T3-TH2	40	113030086	Válvula de 4 vías para intercambiador
7	113100009	Clip	41	116000066	Minipresostato de alta presión
8	113100009	Alojamiento de sonda	42	116000071	Minipresostato de baja presión
9	108110038	Marco superior	43	113010210	Tubo de escape
10	108110043	Soporte del motor del ventilador	44	117110021	Sonda de Tª descarga, T6-TH3
11	117230003	Reactor	45	113020322	Tubería de retorno de gas
12	108480015	Fijación de resistencia evaporador	46	121000006	Válvula de 4 vías
13	108110004	Pilar	47	113060084	Válvula de 4 vías para tuberías colectivas
14	142000079	Resistencia de calentamiento del evaporador	48	119000017	EEV
15	112000031	Motor del ventilador	49	113080054	EEV a tuberías de distribución
16	1330900261	Panel lateral izquierdo	50	113070044	Intercambiador a EEV
17	108010024	Tapa del eje del ventilador	51	113900082	Conjuntos de conexión de agua
18	132000015	Aspa del ventilador	52	112100021-1	Interruptor de flujo de agua
19	133090025	Panel frontal	53	133020011	Anillo de goma rojo
20	108010014	Rejilla ventilador	54	133020026	Junta de goma en la conexión de agua
21	108050073	Panel de aislamiento	55	116000001	Junta de estanqueidad interruptor de flujo de agua.
22	113100008	Tubo de cobre	56	117110011	Sonda de Tª salida agua, T2-TH5
23	120000091	Válvula de globo	57	117110012	Clip del sensor de temperatura del intercambiador
24	142000074	Resistencia de calentamiento del compresor	58	102040708	Intercambiador de calor de titanio
25	101000188	Compresor + bases antivibratorias.	59	133020011	Anillo de goma azul
26	101000188	Compresor + bases antivibratorias.	60	117110012	Sonda Tª de entrada de agua, T1-TH6
27	108110066	Bandeja de base	61	150000110	Tapón de drenaje
28	108010065	Chapa bornas de conexión.	62	108050017	Tapa de caja eléctrica
29	1330900281	Panel derecho	63	117100047	PCB
30	106000011	Manómetro	64	108110057	Caja eléctrica
31	136010004	Presilla para cables de conexión	65	117240002	Anillo magnético
32	115000004	Bornas de conexión	66	117010095	Modulo modbus
33	1332500051	Tapa de plástico de caja de conexión.	67	117240003	Anillo magnético
34	133030011	Caja de controlador			

10

000

Lista de piezas de repuesto/ Modelo: 71679

NO	ERP	Nombre de las partes	NO	ERP	Nombre de las partes
1	1330900291	Tapa del eje del ventilador	35	103000220	Tubería de conexión para intercambiador
2	117110020	Sonda Tª ambiente T5-TH1	36	117020180	Evaporador
3	133020010	Clip sonda Tª ambiente	37	103000220	Tubería evaporador
4	1330900271	Panel trasero	38	136020005	Bloque de goma
5	103000220	Evaporador	39	103000220	Tubería de distribución
6	117110004	Sonda evaporador. Desescarche. T3-TH2	40	113030081	Válvula de 4 vías para intercambiador.
7	113100009	Clip	41	116000066	Minipresostato de alta presión
8	113100009	Alojamiento de sonda	42	116000071	Minipresostato de baja presión
9	108110038	Marco superior	43	113010159	Tubo de escape
10	108110043	Soporte del motor del ventilador	44	117110021	Sonda de Tª descarga, T6-TH3
11	117230003	reactor	45	113020321	Tubería de retorno de gas
12	108480015	Fijación de resistencia evaporador	46	121000006	Válvula de 4 vías
13	108110004	Pilar	47	113060084	Válvula de 4 vías para tuberías colectivas.
14	142000079	Resistencia de calentamiento del evaporador	48	119000017	EEV
15	112000031	Motor del ventilador	49	113080054	EEV a tuberías de distribución
16	1330900261	Panel lateral izquierdo	50	113070041	Intercambiador a EEV
17	108010024	Tapa del eje del ventilador	51	113900082	Conjuntos de conexión de agua
18	132000015	Aspa del ventilador	52	112100021-1	Interruptor de flujo de agua
19	1330900251	Panel frontal	53	133020012	Anillo de goma rojo
20	108010014	Rejilla ventilador	54	133020026	Junta de goma en la conexión de agua
21	108050073	Panel de aislamiento	55	116000001	Junta de estanqueidad interruptor de flujo de agua.
22	113100008	Tubo de cobre	56	117110011	Sonda de Tª salida agua, T2-TH5
23	120000091	Válvula de globo	57	108010025	Clip del sensor de temperatura del intercambiador
24	142000074	Resistencia de calentamiento del compresor	58	102040710	Intercambiador de calor de titanio
25	101000181	Compresor + bases antivibratorias.	59	133020011	Anillo de goma azul
26	101000181	Compresor + bases antivibratorias.	60	117110012	Sonda Tª de entrada de agua, T1-TH6
27	108110044	Bandeja de base	61	150000110	Tapón de drenaje
28	108010065	Chapa bornas de conexión.	62	108050017	Tapa de caja eléctrica
29	133090028	Panel derecho	63	117100047	PCB
30	106000011	Manómetro	64	108110045	Caja

9.7 Modelo: 71680/71681

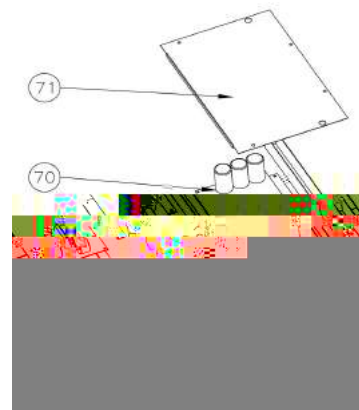
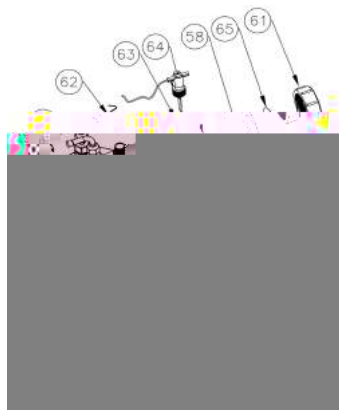
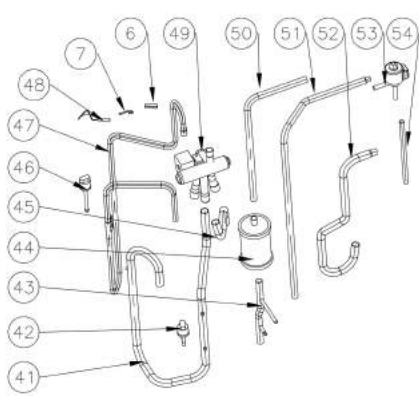
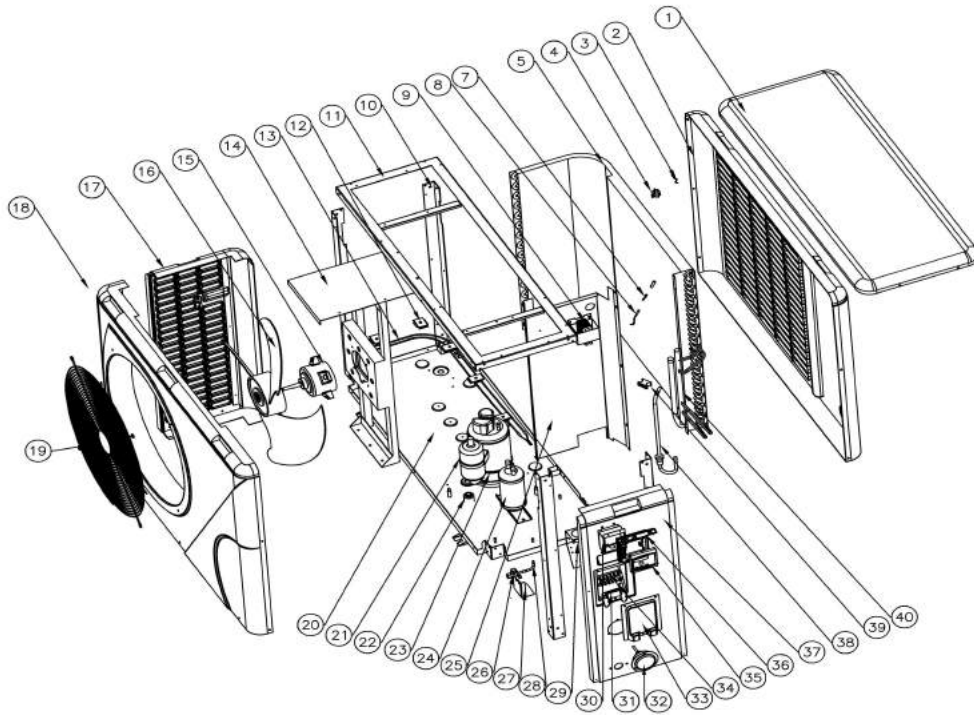

9.8 Lista de piezas de repuesto/ Modelo: 71680

NO	ERP	Nombre de las partes	NO	ERP	Nombre de las partes
1	1332600011	Tapa superior	37	1332600041	Panel derecho
2	1332600021	Panel trasero	38	103000230	Tubería de distribución
3	117110020	Sonda de Tª ambiente T5-TH1	39	136020005	Bloque de goma
4	133020010	Clip sonda Tª ambiente	40	103000230	Tubería evaporador
5	103000230	Evaporador	41	113020338	Tubería de retorno de gas
6	113100009	Alojamiento sonda	42	116000073	Minipresostato de baja presión
7	113100009	Clip	43	113130021	Tubería a filtro deshidratador
8	117110004	Sonda evaporador. Desescarche. T3-TH2	44	120000066	Filtro deshidratador
9	117230002	Reactor	45	113060122	Válvula de 4 vías para tuberías colectivas
10	108560003	Pilar	46	116000068	Minipresostato de alta presión
11	108560002	Marco superior	47	113010244	Tubo de escape
12	108480015	Fijación de resistencia evaporador	48	117110021	Sonda de Tª descarga, T6-TH3
13	142000079	Resistencia de calentamiento del evaporador	49	121000006	Válvula de 4 vías
14	108560011	Soporte del motor del ventilador	50	113170032	Tubería filtro deshidratador
15	112000031	Motor del ventilador	51	113120019	Tubería de cobre a evaporador
16	132000023	Aspa del ventilador	52	113030108	Válvula de 4 vías al intercambiador
17	1332600051	Panel lateral izquierdo	53	119000021	EEV
18	1332600031	Panel frontal	54	113080056	EEV a la tubería de distribución
19	108170017	Rejilla ventilador	55	150000110	Tapón de drenaje
20	108560036	Bandeja de base	56	108010025	Clip del sensor de temperatura del intercambiador
21	101000185	Compresor + bases antivibratorias.	57	117110012	Sonda Tª de entrada de agua, T1-TH6
22	101000185	Compresor + bases antivibratorias.	58	133020026	Junta de goma en la conexión de agua
23	142000077	Resistencia de calentamiento del compresor	59	133020011	Anillo de goma azul
24	105000004	Depósito de líquido	60	102040703	Intercambiador de calor de titanio
25	108560010	Panel de aislamiento	61	113900082	Conjuntos de conexión de agua
26	120000091	Válvula de globo	62	117110011	Sonda de Tª salida agua, T2-TH5
27	108560034	Soporte válvula de globo	63	136020083	Junta de estanqueidad interruptor de flujo de agua.
28	113100008	Tubo de cobre	64	112100021-1	Interruptor de flujo de agua
29	108010065	Chapa bornas de conexión	65	133020012	Anillo de goma roja
30	133030011	Caja de controlador	66	117010095	Módulo Modbus
31	136010004	Presilla para cables de conexión	67	117240002	Anillo magnético
32	106000011	Manómetro	68	117240003	Anillo magnético
33	1332500051	Tapa de plástico de caja de conexión	69	108560012	Caja eléctrica
34	115000004	Bornas de conexión	70	117100048	PCB
35	117020180	Controlador	71	108540006	Tapa de la caja eléctrica
36	113712007	Caja de control impermeable			

9.9 Lista de

NO	ERP	Nombre de la parte	NO	ERP	Nombre de las partes
1	133260001	Capa superior de la...	37	11301004	Tapón de bronce
2	133260002	Tapón de la...	38	11301005	Tubo de escape
3	117110020	Sonda de Tª ambiente TH1	39	11301005	Bloqueo goma
4	133020010	Clip sonda Tª ambiente	40	113000204	Tubería evaporador
5	103000204	Evaporador	41	11301009	Tubería de retorno de gas
6	113100009	Alojamiento sonda	42	113000073	Minipresostato de baja presión
7	113100009	Clip	43	113130021	Tubería a filtro deshidratador
8	117110004	Sonda evaporador. Desescarche. T3-TH2	44	120000066	Filtro deshidratador
9	117230002	Reactor	45	113060096	Válvula de 4 vías para tuberías colectivas
10	108560003	Pilar	46	116000068	Minipresostato de alta presión
11	108560002	Marco superior	47	113010245	Tubo de escape
12	108480015	Fijación de resistencia evaporador	48	117110021	Sonda de Tª descarga, T6-TH3
13	142000144	Resistencia de calentamiento del evaporador	49	121000009	Válvula de 4 vías
14	108560011	Soporte del motor del ventilador	50	113170032	Tubería filtro deshidratador
15	112000031	Motor del ventilador	51	113120019	Tubería de cobre a evaporador
16	132000023	Aspa del ventilador	52	113030093	Válvula de 4 vías al intercambiador
17	1332600051	Panel lateral izquierdo	53	119000021	EEV
18	1332600031	Panel frontal	54	113080056	EEV a la tubería de distribución
19	108170017	Rejilla ventilador	55	150000110	Tapón de drenaje
20	108560036	Bandeja de base	56	108010025	Clip del sensor de temperatura del intercambiador
21	101000185	Compresor + bases antivibratorias.			

9.10 Modelo: 71682,71683

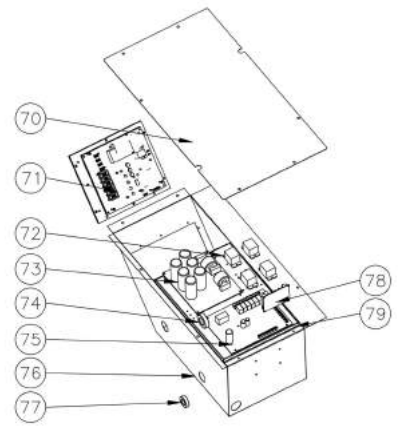
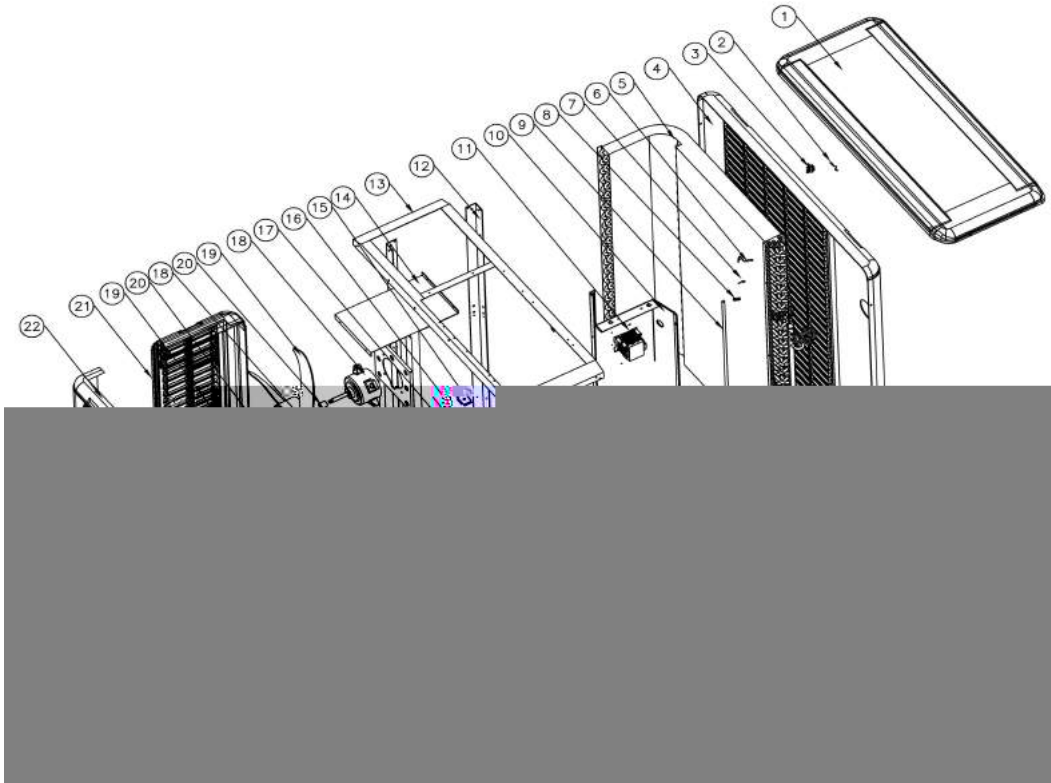

9.11 Lista de piezas de repuesto/ Modelo: 71682

NO	ERP	Nombre de las partes	NO	ERP	Nombre de las partes
1	133100001	Tapa superior	41	117020180	Controlador
2	117110020	Sonda de Tª ambiente T5-TH1	42	113712007	Caja de control impermeable
3	133020010	Clip sonda Tª ambiente	43	103000208	Tubería evaporador
4	133250003	Panel trasero	44	136020005	Bloque de goma
5	103000208	Evaporador	45	113020326	Tubería de retorno de gas
6	117110004	Sonda evaporador. Desescarche. T3-TH2	46	116000073	Minipresostato de baja presión
7	113100009	Clip	47	113060083	Válvula de 4 vías para tuberías
8	113100009	Alojamiento sonda	48	113010227	Tubo de escape
9	103000208	Tubería de distribución	49	113030087	Válvula de 4 vías al intercambiador
10	108120036	Panel de aislamiento	50	121000009	Válvula de 4 vías
11	117230001	Reactor	51	116000008	Minipresostato de alta presión
12	108120035	Pilar	52	117110021	Sonda de Tª descarga, T6-TH3
13	108120034	Marco superior	53	113120020	Tubería de cobre a evaporador
14	108120044	Soporte del motor del ventilador	54	113130020	Tubería a filtro deshidratador
15	108480015	Fijación de resistencia evaporador	55	113080055	EEV a la tubería de distribución
16	142000079	Resistencia de calentamiento del evaporador	56	119000021	EEV
17	108550009	Pilar	57	120000066	Filtro deshidratador
18	112000031	Motor del ventilador	58	113170028	Tubería filtro deshidratador
19	132000015	Aspa del ventilador	59	112100021-1	Interruptor de flujo de agua
20	108010024	Tapa del eje del ventilador	60	117110011	Sonda de Tª salida agua, T2-TH5
21	133250004	Panel lateral izquierdo	61	108010025	Clip del sensor de temperatura del intercambiador
22	133250001	Panel frontal	62	102040749	Intercambiador de calor de titanio
23	108010014	Rejilla ventilador	63	113900082	Conjuntos de conexión de agua
24	120000091	Válvula de globo	64	133020012	Anillo de goma azul
25	113100008	Tubo de cobre	65	133020026	Junta de goma en la conexión de agua
26	101000185	Compresor + bases antivibratorias.	66	117110012	Sonda Tª de entrada de agua, T1-TH6
27	101000185	Compresor + bases antivibratorias.	67	150000110	Tapón de drenaje
28	105000008	Depósito de líquido	68	133020011	Anillo de goma roja
29	142000077	Resistencia de calentamiento del compresor	69	136020083	Junta de estanqueidad interruptor de flujo de agua.
30	108550005	Bandeja de base	70	108120040	Tapa de la caja eléctrica
31	108550008	Tensor chapa	71	117140016	PCB control principal
32	108010065	Chapa bornas de conexión	72	142000038	Relé
33	133250002	Panel derecho	73	117260001	Placa de filtros
34	115000025	Bornas de conexión	74	117240002	Anillo magnético
35	106000011	Manómetro	75	117250007	PCB
36	136010004	Presilla para cables de conexión	76	108120038	Caja electrica
37	108550006	Soporte bornas	77	117240003	Anillo magnético
38	115000027	Bornas de conexión sistema filtración	78	117010095	Módulo Modbus
39	133250005	Tapa de plástico de caja de conexión.	79	108120039	Cuadro eléctrico
40	133030011	Caja de Controlador			

9.12 Lista de piezas de repuesto/ Modelo: 71683

NO	ERP	Nombre de las partes	NO	ERP	Nombre de las partes
1	133100001	Tapa superior	41	117020180	Controlador
2	117110020	Sonda de Tª ambiente T5-TH1	42	113712007	Caja de control impermeable
3	133020010	Clip sonda Tª ambiente	43	103000209	Tubería Evaporador
4	133250003	Panel trasero	44	136020005	Bloque de goma
5	103000209	Evaporador	45	113020389	Tubería de retorno de gas
6	117110004	Sonda evaporador. Desescarche. T3-TH2	46	116000073	Minipresostato de baja presión
7	113100009	Clip	47	113060083	Válvula de 4 vías para tuberías colectivas
8	113100009	Alojamiento sonda	48	113010228	Tubo de escape
9	103000209	Tubería de distribución	49	113030087	Válvula de 4 vías al intercambiador
10	108120036	Panel de aislamiento	50	121000009	Válvula de 4 vías
11	117230001	Reactor	51	116000008	Minipresostato de alta presión
12	108120035	Pilar	52	117110021	Sonda de Tª descarga, T6-TH3
13	108120034	Marco superior	53	113120020	Tubería de cobre a evaporador
14	108120044	Soporte del motor del ventilador	54	113130020	Tubería a filtro deshidratador
15	108480015	Fijación de resistencia evaporador	55	113080055	EEV a la tubería de distribución
16	142000079	Resistencia de calentamiento del evaporador	56	119000042	EEV
17	108550009	Pilar	57	120000066	Filtro deshidratador
18	112000031	Motor del ventilador	58	113170028	Tubería filtro deshidratador
19	132000015	Aspa del ventilador	59	112100021-1	Interruptor de flujo de agua
20	108010024	Tapa del eje del ventilador	60	117110011	Sonda de Tª salida agua, T2-TH5
21	133250004	Panel lateral izquierdo	61	108010025	Clip del sensor de temperatura del intercambiador
22	133250001	Panel frontal	62	102040754	Intercambiador de calor de titanio
23	108010014	Rejilla ventilador	63	113900082	Conjuntos de conexión de agua
24	120000091	Válvula de globo	64	133020012	Anillo de goma azul
25	113100008	Tubo de cobre	65	133020026	Junta de goma en la conexión de agua
26	101000186	Compresor + bases antivibratorias	66	117110012	Sonda Tª de entrada de agua, T1-TH6
27	101000186	Compresor + bases antivibratorias	67	150000110	Tapón de drenaje
28	105000008	Depósito de líquido	68	133020011	Anillo de goma roja
29	142000077	Resistencia de calentamiento del compresor	69	136020083	Junta de estanqueidad interruptor de flujo de agua.
30	108470069	Bandeja de base	70	108120040	Tapa de la caja eléctrica
31	108550008	Tensor chapa	71	117140016	PCB control principal
32	108010065	Chapa bornas de conexión	72	142000038	Relé
33	133250002	Panel derecho	73	117260001	Placa de filtros
34	115000025	Bornas de conexión	74	117240002	Anillo magnético
35	106000011	Manómetro	75	117250007	PCB
36	136010004	Presilla para cables de conexión	76	108120038	Caja electrica
37	108550006	Soporte bornas	77	117240003	Anillo magnético
38	115000027	Resistencia de calentamiento del evaporador	78	117010095	Módulo Modbus
39	133250005	Tapa de plástico de caja de conexión	79	108120039	Cuadro eléctrico
40	133030011	Caja de controlador			

9.13 Modelo: 68821/68822/68823

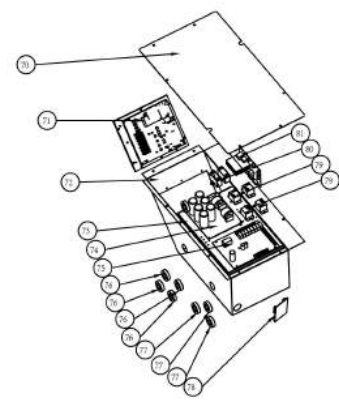
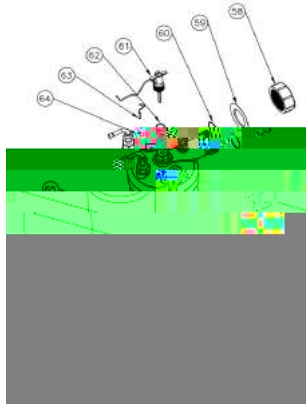
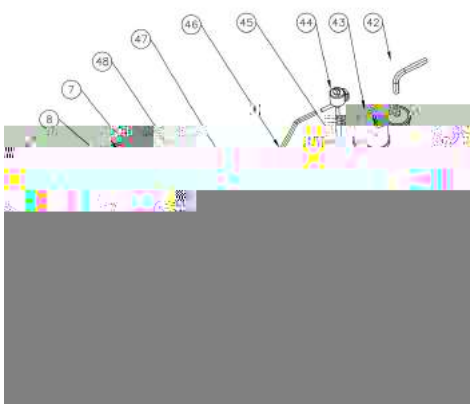
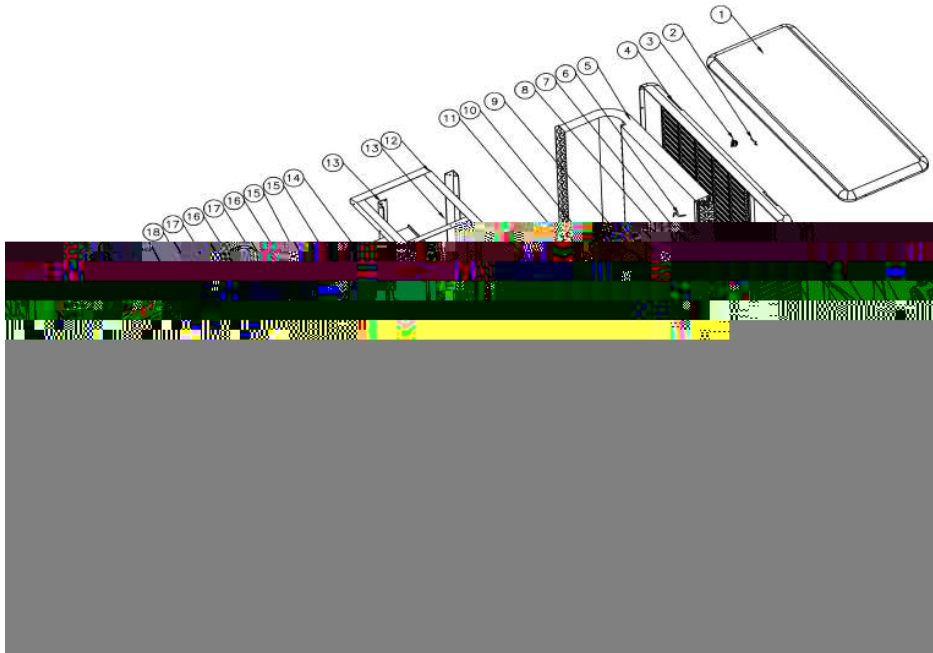

9.14 Modelo: 68821

NO	ERP	Nombre de las partes	NO	ERP	Nombre de las partes
1	133100001	Tapa superior	41	113050109	Tubería colectiva
2	117110020	Sonda de Tª ambiente T5-TH1	42	113170028	Tubería filtro deshidratador
3	133020010	Clip sonda Tª ambiente	43	120000066	Filtro deshidratador
4	133250003	Panel trasero	44	119000022	EEV
5	103000153	Evaporador	45	113080055	EEV a la tubería de distribución
6	117110004	Sonda evaporador. Desescarche. T3-TH2	46	113120020	Tubería de cobre a evaporador
7	113190001	Clip	47	113030087	Válvula de 4 vías al intercambiador
8	113190001	Alojamiento sonda	48	117110021	Sonda de Tª descarga, T6-TH3
9	113040101	Tubería de distribución	49	116000008	Minipresostato de alta presión
10	108550010	Panel de aislamiento	50	121000009	Válvula de 4 vías
11	117230002	Reactor	51	120000023	Válvula de aspiración
12	108120034	Marco superior	52	113010158	Tubo de escape
13	108120035	Pilar	53	116000080	Minipresostato de baja presión 0.2-0.35
14	108120037	Soporte del motor del ventilador	54	116000079	Minipresostato de baja presión 0.1-0.3
15	112000031	Motor del ventilador	55	113020245	Tubería de retorno de gas
16	108010024	Tapa del eje del ventilador	56	113060083	Válvula de 4 vías para tuberías colectivas
17	132000015	Aspa del ventilador	57	113130015	Tubería a filtro deshidratador
18	133250004	Panel lateral izquierdo	58	113900082	Conjuntos de conexión de agua
19	133250001	Panel frontal	59	133020011	Anillo de goma roja
20	108010014	Rejilla ventilador	60	133020026	Junta de goma en la conexión de agua
21	108550009	Pilar	61	112100021-1	Interruptor de flujo de agua
22	108550005	Bandeja de base	62	116000001-2	Junta de estanqueidad interruptor de flujo de agua.
23	101000149	Compresor + bases antivibratorias.	63	117110011	Sonda de Tª salida agua, T2-TH5
24	105000008	Depósito de líquido	64	108010025	Clip del sensor de temperatura del intercambiador
25	142000077	Resistencia de calentamiento del	65	113900082	Conjuntos de conexión de agua
26	101000149	Compresor + bases antivibratorias.	66	133020012	Anillo de goma azul
27	108550008	Tensor chapa	67	102040503	Intercambiador de calor de titanio
28	108010065	Chapa bornas de conexión	68	117110012	Sonda Tª de entrada de agua, T1-TH6
29	110000008	Junta de goma	69	150000110	Tapón de drenaje
30	108010018	Caja de controlador	70	108120040	Tapa de la caja eléctrica
31	133250002	Panel derecho	71	117140003	PCB control principal
32	115000025	Bornas de conexión	72	108120038	Caja electrica
33	110800001	Manómetro	73	108120039	Chapa soporte componentes eléctricos
34	136010004	Presilla para cables de conexión	74	117260002	Placa de filtros
35	108550006	Pilar	75	117250001-V1.5	PCB
36	115000027	Bornas de conexión sistema filtración	76	117240002	Anillo magnético
37	133250005	Tapa de plástico de caja de conexión	77	117240003	Anillo magnético
38	113712007	Caja de control impermeable	78	117010095	Módulo Modbus
39	117020150	Controlador	79	142000038	Relé
40	136020005	Bloque de goma	80	N/A	N/A
			81	117140006	Placa del motor del ventilador

9.14 Modelo: 68822

NO	ERP	Nombre de partes	NO	ERP	Nombre de partes
1	133100001	Tapa superior	41	113050110	Tubería colectiva
2	117110020	Sonda de Tª ambiente T5-TH1	42	113170028	Tubería filtro deshidratador
3	133020010	Clip sonda Tª ambiente	43	120000066	Filtro deshidratador
4	133250003	Panel trasero	44	119000022	EEV
5	103000154	Evaporador	45	113080055	EEV a la tubería de distribución
6	117110004	Sonda evaporador. Desescarche. T3-TH2	46	113120020	Tubería de cobre a evaporador
7	113190001	Clip	47	113030087	Válvula de 4 vías al intercambiador
8	113190001	Alojamiento sonda	48	117110021	Sonda de Tª descarga, T6-TH3
9	113040102	Tubería de distribución	49	116000008	Minipresostato de alta presión
10	108550010	Panel de aislamiento	50	121000009	Válvula de 4 vías
11	117230004	Reactor	51	120000023	Válvula de aspiración
12	108120034	Marco superior	52	113010158	Tubo de escape
13	108120035	Pilar	53	116000080	Minipresostato de baja presión 0.2-0.35
14	108120037	Soporte del motor del ventilador	54	116000079	Minipresostato de baja presión 0.1-0.3
15	112000031	Motor del ventilador	55	113020245	Tubería de retorno de gas
16	108010024	Tapa del eje del ventilador	56	113060083	Válvula de 4 vías para tuberías colectivas
17	132000015	Aspa del ventilador	57	113130015	Tubería a filtro deshidratador
18	133250004	Panel lateral izquierdo	58	113900082	Conjuntos de conexión de agua
19	133250001	Panel frontal	59	133020011	Anillo de goma roja
20	108010014	Rejilla ventilador	60	133020026	Junta de goma en la conexión de agua
21	108550009	Pilar	61	112100021-1	Interruptor de flujo de agua
22	108550005	Bandeja de base	62	116000001-2	Junta de estanqueidad interruptor de
23	101000122	Compresor + bases antivibratorias.	63	117110011	Sonda de Tª salida agua, T2-TH5
24	105000008	Depósito de líquido	64	108010025	Clip del sensor de temperatura del
25	142000077	Resistencia de calentamiento del compresor	65	113900082	Conjuntos de conexión de agua
26	101000122	Compresor + bases antivibratorias.	66	133020012	Anillo de goma azul
27	108550008	Tensor chapa	67	102040502	Intercambiador de calor de titanio
28	108010065	Chapa bornas de conexión	68	117110012	Sonda Tª de entrada de agua, T1-TH6
29	110000008	Junta de goma	69	150000110	Tapón de drenaje
30	108010018	Caja de controlador	70	108120040	Tapa de la caja eléctrica
31	133250002	Panel derecho	71	117140002	PCB control principal
32	115000025	Bornas de conexión	72	108120038	Caja electrica
33	110800001	Manómetro	73	108120039	Chapa soporte componentes eléctricos
34	136010004	Presilla para cables de conexión	74	117260001	Placa de filtros
35	108550006	Pilar	75	117250001-V1.5	PCB
36	115000027	Bornas de conexión sistema filtración	76	117240002	Anillo magnético
37	133250005	Tapa de plástico de caja de conexión	77	117240003	Anillo magnético
38	113712007	Caja de control impermeable	78	117010095	Módulo Modbus
39	117020150	Controlador	79	142000038	Relé
40	136020005	Bloque de goma	80	N/A	N/A
			81	N/A	N/A

9.15 Modelo: 68823

NO	ERP	Nombre de partes	NO	ERP	Nombre de partes
1	133100001	Tapa superior	41	113050110	Tubería colectiva
2	117110020	Sonda de Tª ambiente T5-TH1	42	113170028	Tubería filtro deshidratador
3	133020010	Clip sonda Tª ambiente	43	120000066	Filtro deshidratador
4	133250003	Panel trasero	44	119000022	EEV
5	103000154	Evaporador	45	113080055	EEV a la tubería de distribución
6	117110004	Sonda evaporador. Desescarche. T3-TH2	46	113120020	Tubería de cobre a evaporador
7	113190001	Clip	47	113030087	Válvula de 4 vías al intercambiador
8	113190001	Alojamiento sonda	48	117110021	Sonda de Tª descarga, T6-TH3
9	113040102	Tubería de distribución	49	116000008	Minipresostato de alta presión
10	108550010	Panel de aislamiento	50	121000009	Válvula de 4 vías
11	117230002	Reactor	51	120000023	Válvula de aspiración
12	108120034	Marco superior	52	113010158	Tubo de escape
13	108120035	Pilar	53	116000080	Minipresostato de baja presión 0.2-0.35
14	108120037	Soporte del motor del ventilador	54	116000079	Minipresostato de baja presión 0.1-0.3
15	112000031	Motor del ventilador	55	113020245	Tubería de retorno de gas
16	108010024	Tapa del eje del ventilador	56	113060083	Válvula de 4 vías para tuberías colectivas
17	132000015	Aspa del ventilador	57	113130015	Tubería a filtro deshidratador
18	133250004	Panel lateral izquierdo	58	113900082	Conjuntos de conexión de agua
19	133250001	Panel frontal	59	133020011	Anillo de goma roja
20	108010014	Rejilla ventilador	60	133020026	Junta de goma en la conexión de agua
21	108550009	Pilar	61	112100021-1	Interruptor de flujo de agua
22	108550005	Bandeja de base	62	116000001-2	Junta de estanqueidad interruptor de
23	101000149	Compresor + bases antivibratorias.	63	117110011	Sonda de Tª salida agua, T2-TH5
24	105000008	Depósito de líquido	64	108010025	Clip del sensor de temperatura del intercambiador
25	142000077	Resistencia de calentamiento del compresor	65	113900082	Conjuntos de conexión de agua
26	101000149	Compresor + bases antivibratorias.	66	133020012	Anillo de goma azul
27	108550008	Tensor chapa	67	102040502	Intercambiador de calor de titanio
28	1113712007	Chapa bornas de conexión	68	117110012	Sonda Tª de entrada de agua, T1-TH6
29	110000008	Junta de goma	69	150000110	Tapón de drenaje
30	108010018	Caja de controlador	70	108120040	Tapa de la caja eléctrica
31	133250002	Panel derecho	71	117140003	PCB control principal
32	115000006	Bornas de conexión	72	108120038	Caja electrica
33	110800001	Manómetro	73	108120039	Chapa soporte componentes eléctricos
34	136010004	Presilla para cables de conexión	74	117260002	Placa de filtros
35	108550006	Pilar	75	117250001-V1.5	PCB
36	115000027	Bornas de conexión sistema filtración	76	117240002	Anillo magnético
37	133250005	Tapa de plástico de caja de conexión	77	117240003	Anillo magnético
38	113712007	Caja de control impermeable	78	117010095	Módulo Modbus
39	117020150	Controlador	79	142000038	Relé
40	136020005	Bloque de goma	80	N/A	N/A
			81	117140006	Placa del motor del ventilador

9.17 Mantenimiento

(1) Debe revisar regularmente el sistema del abastecimiento del agua para evitar que el aire entre al sistema y provoque bajo caudal de agua, ya que estas averías reducirán el rendimiento y la fiabilidad de la unidad de la bomba de calor.

(2) Debe limpiar regularmente sus piscinas y el sistema de filtración para evitar el daño a la unidad por suciedad del sistema de filtración..

(3) Mantenga la unidad de la bomba de calor seca, bien ventilada y siempre limpia el lado del intercambiador de calor que puede mantener un buen intercambio de calor y ahorro de energía.

(4) Sólo un técnico calificado está autorizado a operar la presión del sistema de refrigeración.

(5) Verifique la conexión del cable de potencia, si la bomba de calor comienza a funcionar de manera anormalmente, usted deberá apagarla y entrar en contacto con un técnico calificado.

(6) Por favor, siempre vacíe el agua de la bomba de calor cuando esté parada durante el invierno o cuando la temperatura ambiente descienda por debajo de 0 °C, o de lo contrario, el intercambiador de titanio se dañará por congelación, en tal caso, se perderá la garantía.

(7) Cualquier operación en la bomba de calor debe ser realizada por un profesional con licencia de manipulador de gases R32.

(8) Por favor llene el gas R32 por la válvula de globo, que está dentro de la máquina.



Vielen Dank dass Sie sich für die Pro-Wärmepumpe für das Beheizen ihres Schwimmbeckens entschieden haben. Diese wird ihr Poolwasser erwärmen und auf einer konstanten Temperatur halten, wenn die Außentemperatur zwischen -20°C und 50°C liegt.

 **ACHTUNG: Dieses Handbuch beinhaltet alle Informationen, die für die Benutzung und die Installation ihrer Wärmepumpe erforderlich sind.**

Der Installateur muss das Handbuch gründlich durchlesen und die Anweisungen folgen, auch bei der Wartung.

Der Installateur ist verantwortlich für die Installation des

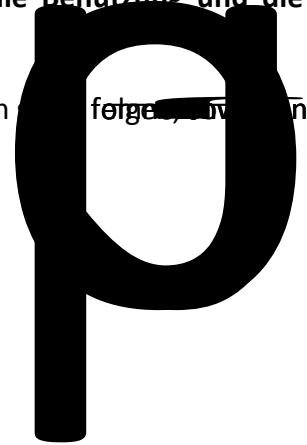

1.1 Im Lieferumfang zur Wärmepumpe ist enthalten:

- Wasseranschluss 50 mm (Stück: 2)
- Benutzer und Service Handbuch
- Druckminderer
- 10 m Verlängerungskabel für das Display
- Wasserdichter Kasten
- Winterabdeckung
- Schwingungsdämpfer (Stück: 4)

1.2 Abmessung

Modell: 71676

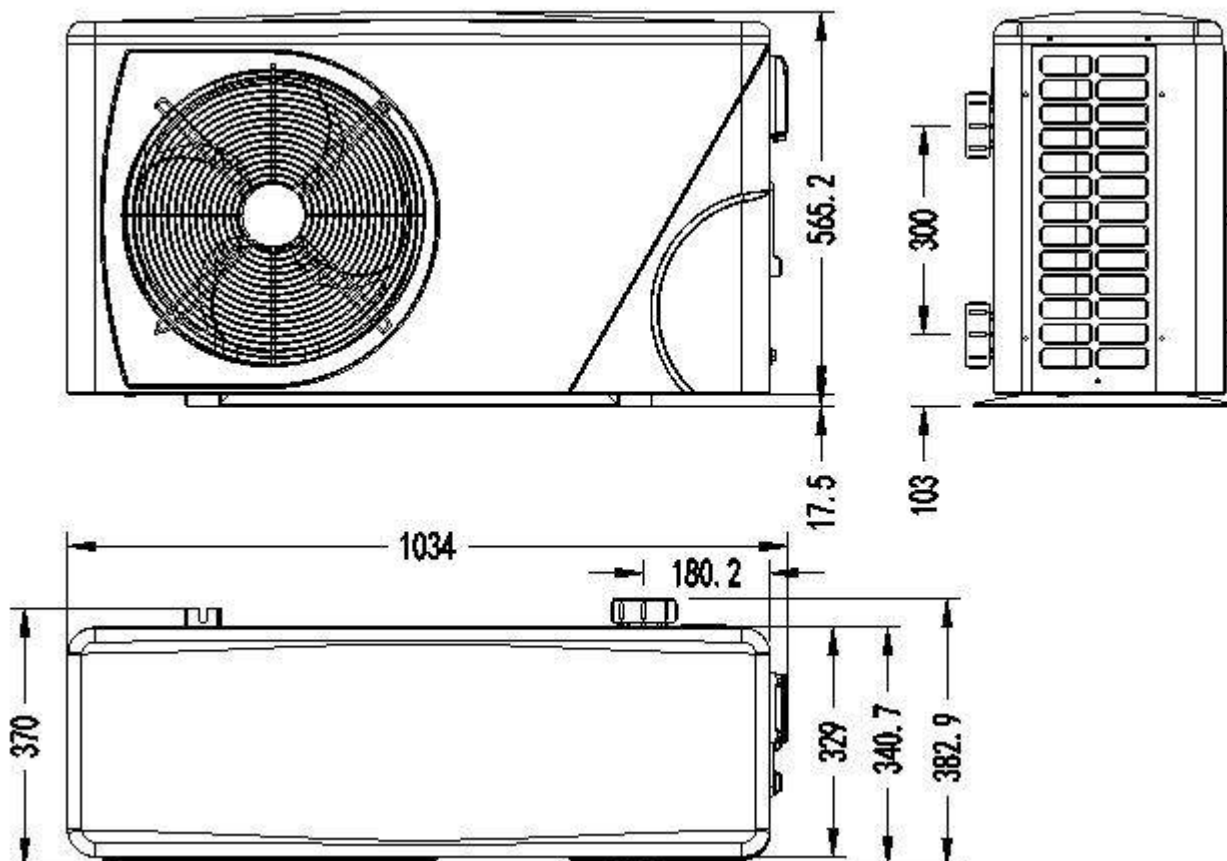

Modelle: 71677/71678/71679

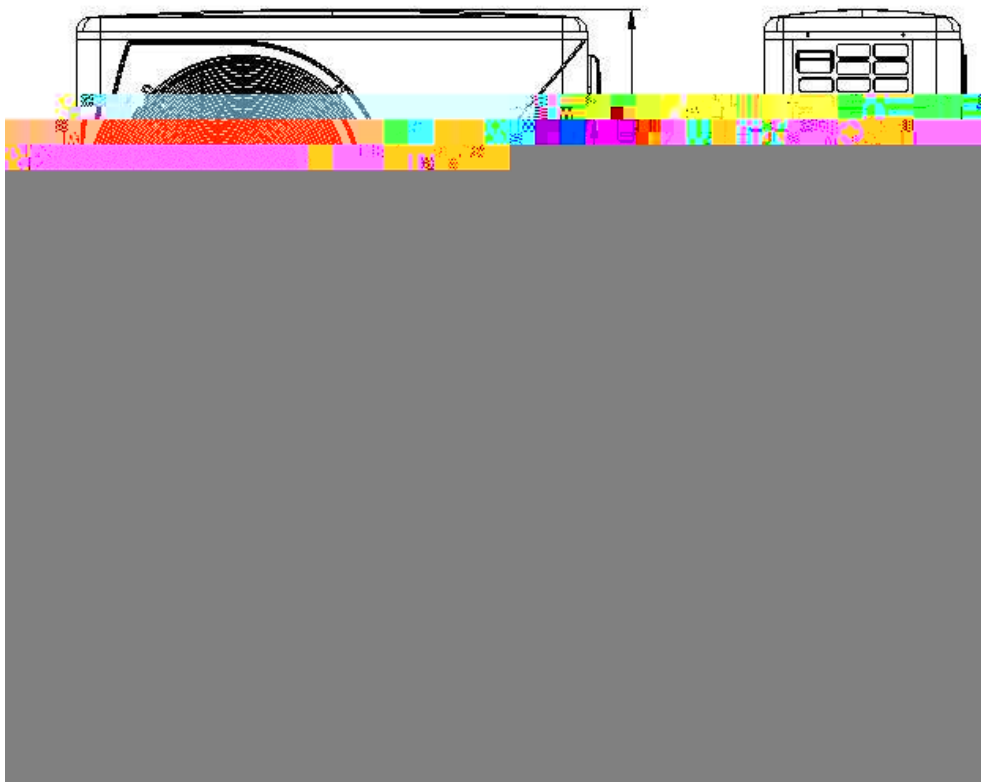

Modelle: 71680/71681

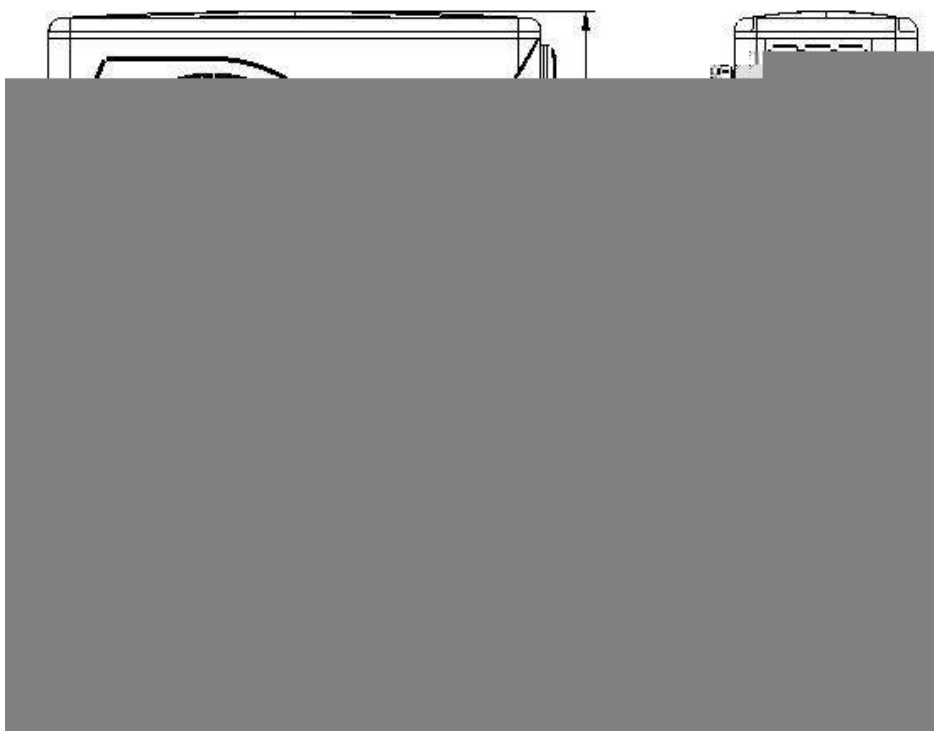

Modelle: 71682/71683/68821/68822/68823



2.1 Lieferung der Verpackung



Für den Transport ist die Wärmepumpe auf der Palette fixiert und mit einer Kartonschachtel abgedeckt.

Um Beschädigungen vorzubeugen, muss die Wärmepumpe auf die Palette übertragen werden.

Sämtliches Material, auch wenn der Transport dem Lieferanten in Rechnung gestellt wird, kann bei der Weiterleitung beim Kunden beschädigt werden und es liegt in der Verantwortung des Empfängers, die Übereinstimmung der Lieferung sicherzustellen

Der Adressat hat alle Rücklagen an der Rezeption auf dem Lieferschein des Frachtführers zu vermerken, wenn er Beschädigungen der Verpackung bemerkt. VERGESSEN SIE NICHT, MIT EINEM EINGETRAGENEN BRIEF AN DEN TRÄGER UNTER 48 H. ZU BESTÄTIGEN

2.2 Bestandsberatung

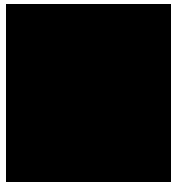

Technische Daten zu den PRO ELYO INVERBOOST NN-Poolwärmepumpen

CE-Norm, R32, ABS-Schrank

MODEL		PROELYXP07i	PROELYXP09i	PROELYXP11i	PROELYXP14i
CODE		71676	71677	71678	71679
*Leistung bei Luft 28°C, Wasser 28°C, Luftfeuchtigkeit 80%					
Heizleistung	Kw	7-3.1	9-2.3	11-2.9	14-3.2
Energieverbrauch	Kw	1.04-0.21	1.34-0.14	1.64-0.18	2.09-0.2
C.O.P.		15-6.7	16-6.7	16-6.7	16-6.7
* Leistung bei Luft 15°C, Wasser 26°C, Luftfeuchtigkeit 70%					
Heizleistung	Kw	4.7-2.5	6.6-1.9	7.9-2	9.5-2.3
Energieverbrauch	Kw	0.94-0.32	1.32-0.24	1.58-0.25	1.9-0.29
C.O.P.		7.9-5	8.0-5	8.0-5	8.0-5
* Leistung bei Luft 0°C, Wasser 26°C, Luftfeuchtigkeit 78%					
Heizleistung	Kw	3.44-1.7	4.11-2.3	5.54-3.0	6.85-3.8
Energieverbrauch	Kw	1.23-0.38	1.47-0.82	1.98-0.68	2.45-0.85
C.O.P.		4.5-2.8	4.4-2.8	4.4-2.8	4.5-2.8
* Leistung bei Luft -10°C, Wasser 26°C, Luftfeuchtigkeit 78%					
Heizleistung	Kw	2.41-1.5	3.13-2.0	3.87-2.7	5.1-3.15
Energieverbrauch	Kw	1.21-0.35	1.42-0.53	1.76-0.69	2.32-0.81
C.O.P.		4.3-2	3.8-2.2	3.9-2.2	3.9-2.2
* Allgemeine Daten					
Kompressortyp		MITSUBISHI-INVERTER-KOMPRESSOR			
Netzspannung	V	220-240V/50Hz or 60Hz/1PH			
Nennstrom	A	4.6	5.9	7.2	9.2
Mindestabsicherung	A	7	9	11	14
Empfohlenes Pool Volumen(mit Poolabdeckung)	m ³	10-26	12-35	16-60	18-66
Empfohlener Durchfluss	m ³ /h	2.5	3.0	3.7	4.0
Wasserdruckverlust	Kpa	12	12	14	15
Wärmetauscher		Dreh-Titan-Schlauch aus PVC			
Wasseranschluss	mm	50			
Lüftermenge		1			
Lüftung		Horizontal			
Lüfterdrehzahl	RPM	500-850		550-850	
Stromaufnahme des Lüfters	W	6-35		22-82	32-110
Geräuschpegel in 10m Entfernung)	dB(A)	≤ 41	≤ 42	≤ 42	≤ 43
Geräuschpegel (in 1m Abstand)	dB(A)	38-51	39-52	40-52	40-54
Kältemittel (R32)	g	650	700	1000	1100
CO2 gleichwertig	Tonne	0.44	0.47	0.68	0.74
* Dimension/ Weight					
Nettogewicht	kg	56	68	73	78
Bruttogewicht	kg	68	73	78	83
Nettodimension	mm	1008*380*577	1050*440*709		
Verpackungsmaß	mm	1095*430*705	1130*470*850		

Technische Daten zu den PRO ELYO INVERBOOST NN Poolwärmepumpen

CE-Norm, R32, ABS-Schrank

MODEL		PROELYXP16i	PROELYXP20i	PROELYXP26i	PROELYXP30i
CODE		71680	71681	71682	71683
*Leistung bei Luft 28°C, Wasser 28°C, Luftfeuchtigkeit 80%					
Heizleistung	Kw	16-3.8	20-4.7	26-5.9	30-6.8
Energieverbrauch	Kw	2.39-0.24	2.99-0.29	3.88-0.37	4.55-0.43
C.O.P.		16-6.7	16-6.7	16-6.7	16-6.6
* Leistung bei Luft 15°C, Wasser 26°C, Luftfeuchtigkeit 70%					
Heizleistung	Kw	11.2-3	14-3.9	18-5.4	22.8-5.6
Energieverbrauch	Kw	2.24-0.38	2.8-0.49	3.6-0.68	4.56-0.68
C.O.P.		8.2-5	8.2-5	8.2-5	8.2-5
* Leistung bei Luft 0°C, Wasser 26°C, Luftfeuchtigkeit 78%					
Heizleistung	Kw	7.4-4.1	9.79-4.8	13-6.7	15.89-8.5
Energieverbrauch	Kw	2.64-0.91	3.5-1.09	4.64-1.52	5.68-1.93
C.O.P.		4.5-2.8	4.4-2.8	4.4-2.8	4.4-2.8
* Leistung bei Luft -10°C, Wasser 26°C, Luftfeuchtigkeit 78%					
Heizleistung	Kw	5.8-3.6	7.58-4.3	10.4-5.9	12.74-7.4
Energieverbrauch	Kw	2.64-0.92	3.45-1.1	4.73-1.51	5.79-1.95
C.O.P.		3.9-2.2	3.9-2.2	3.9-2.2	3.8-2.2
* Allgemeine Daten					
Kompressortyp		GMCC /TOSHIBA		MITSUBISHI	
Netzspannung	V	220-240V/50Hz or 60Hz/1PH			
Nennstrom	A	10.5	13.2	17.0	23.0
Mindestabsicherung	A	16	20	26	35
Empfohlenes Pool Volumen (mit Poolabdeckung)	m ³	28-85	58-120	65-132	78-156
Empfohlener Durchfluss	m ³ /h	5.0	6.0	8.0	10.0
Wasserdruckverlust	Kpa	15	18	20	25
Wärmetauscher		Dreh-Titan-Schlauch aus PVC			
Wasseranschluss	mm	50			
Lüftermenge		1			
Lüftung		Horizontal			
Lüfterdrehzahl	RPM	450-650		(550-850)*2	
Stromaufnahme des Lüfters	W	35-130		(32-110)*2	
Geräuschpegel in 10m Entfernung)	dB(A)	≤ 43	≤ 45	≤ 49	≤ 49
Geräuschpegel (in 1m Abstand)	dB(A)	40-54	41-56	42-60	42-60
Kältemittel (R32)	g	1500	1900	2000	2600
CO2 gleichwertig	Tonne	1.01	1.28	1.35	1.76
* Dimension/ Weight					
Nettogewicht	kg	98	117	128	130
Bruttogewicht	kg	113	135	146	148
Nettodimension	mm	1050*450*870		1050*452*1295	
Verpackungsmaß	mm	1140*480*1010		1130*515*1430	

Technische Daten zu den PRO ELYO INVERBOOST NN Poolwärmepumpen

CE-Norm, R410A, ABS-Schrank

MODEL		Pro Elyo Inverboost NN26T	Pro Elyo Inverboost NN 35	Pro Elyo Inverboost NN35T
CODE		68821	68822	68823
*Leistung bei Luft 28°C, Wasser 28°C, Luftfeuchtigkeit 80%				
Heizleistung	Kw	26-5.9	35-8	35-8
Energieverbrauch	Kw	3.88-0.37	5.22-0.5	5.22-0.5
C.O.P.		16-6.7	16-6.7	16-6.7
* Leistung bei Luft 15°C, Wasser 26°C, Luftfeuchtigkeit 70%				
Heizleistung	Kw	18-5.4	24-5.6	24-5.6
Energieverbrauch	Kw	3.6-0.68	4.8-0.68	4.8-0.68
C.O.P.		8.2-5	8.2-5	8.2-5
* Leistung bei Luft 0°C, Wasser 26°C, Luftfeuchtigkeit 78%				
Heizleistung	Kw	13-6.7	15.8-3.7	15.8-3.7
Energieverbrauch	Kw	4.64-1.52	4.46-0.63	4.46-0.63
C.O.P.		4.4-2.8	5.8-3.6	5.8-3.6
* Leistung bei Luft 0°C, Wasser 26°C, Luftfeuchtigkeit 78%				
Heizleistung	Kw	10.4-5.9	11.6-3.1	11.6-3.1
Energieverbrauch	Kw	4.73-1.51	4.77-0.6	4.77-0.6
C.O.P.		3.9-2.2	5.2-2.45	5.2-2.45
* Allgemeine Daten				
Kompressortyp		MITSUBISHI INVERTOR COMPRESSOR		
Netzspannung	V	380V/50Hz or 60Hz/3PH	220~240V /50Hz or 60Hz/1PH	380V/50Hz or 60Hz/3PH
Nennstrom	A	7	22.9	8.4
Mindestabsicherung	A	10.5	34	13
Empfohlenes Pool Volumen (mit Poolabdeckung)	m ³	65-132	78-160	78-160
Empfohlener	m ³ /h	8.00	10.0	10.0
Wasserdruckverlust	Kpa	20	25	25
Wärmetauscher		Twist-titanium tube in PVC		
Wasseranschluss	mm	50		
Lüftermenge		2		
Lüftung		Horizontal		
Lüfterdrehzahl	RPM	(550-850)*2		
Stromaufnahme des	W	(32-110)*2		
Geräuschpegel in 10m	dB(A)	/	/	/
Geräuschpegel in 1m	dB(A)	42-60	42-60	42-60
Kältemittel (R410a)	g	3800	4000	4000
CO2 gleichwertig	Tonne	7.94	8.36	8.36
* Abmessungen/Gewicht				
Nettogewicht	kg	128		
Bruttogewicht	kg	146		
Nettodimension	mm	1050*452*1295		
Verpackungsmaß	mm	1130*515*1430		

*Vorstehende Daten können ohne vorherige Ankündigung geändert werden

4.1 Zubehörliste

		
Schwingungsdämpfer , Anzahl 4	Bodenwannentleerung, Anzahl 2	Schutzhülle, Menge 1
		
10M Displayverlängerungskabel, 1 Stk Modbus-Signaldraht, 1 Stk	Anschlussverschraubung für Einlass und Auslass von Wasser, Anzahl 2	Winter-Abdeckung, 1 stk

4.2 Das Bypass-Kit

Das Kit By-Pass ist das unentbehrliche Zubehör für die Installation Ihrer Wärmepumpe, es ist auch ein Instrument für die Optimierung der Wassererwärmung. Die Regelung der Ventile ermöglicht, um den Wasserfluss zu optimieren, und mit dem Manometer, um die Optimierung der Kompressor Lauf sicherzustellen.



4.3 Zubehör für die Installation



Schwingungsdämpfer

1. Nehmen Sie 4 Schwingungsdämpfer heraus
2. Befestigen Sie diese unten am Chassis der Wärmepumpe.



Entleerungsstutzen

1. Installieren Sie die Ablassstutzen unter der Auffangwanne
2. Schließen Sie eine Wasserleitung an, um das Wasser abzulassen.

Hinweis: Heben Sie die Wärmepumpe an, um den Ablauf zu installieren. Niemals die Wärmepumpe umkippen, sie könnte den Kompressor beschädigen.



Wasserzulauf & Rücklauf

1. Montieren Sie die die Verschraubung wie im Bild gezeigt
2. Schrauben Sie sie auf den Wasserzulauf- und - Rücklauf



Netzanschluss

1. Öffnen Sie den Verdrahtungskasten (rot markiert) an der Seite der Maschine
2. Befestigen Sie die andere Seite an den Verbindungsstellen in der elektrischen Box.



Verdrahtung der Wasserpumpe (Trockenkontakt)

1. Öffnen Sie den Verdrahtungskasten (rot markiert) an der Seite der Maschine
2. Befestigen Sie die andere Seite an den Verbindungsstellen in der elektrischen Box.

ACHTUNG:

Bitte beachten Sie bei der Installation der Wärmepumpe die folgenden Regeln:

1. Die Zugabe von Chemikalien muss in den der Wärmepumpe nachgeschalteten Rohrleitungen erfolgen.
2. Stellen Sie die Wärmepumpe immer aufrecht hin. Wenn das Gerät geneigt gehalten wurde, warten Sie mindestens 24 Stunden, bevor Sie die Wärmepumpe an den Netzstrom anschließen.

5.1 Positionierung der Wärmepumpe

Die Einheit wird an jeder gewünschten Position richtig arbeiten, solange die folgenden drei Elemente vorhanden sind:

- 1. Frische Luft – 2. Elektrizität – 3. Schwimmbeckenfilter**

Die Einheit kann praktisch an jedem Standort im Außenbereich installiert werden, solange die angegebenen Mindestabstände zu anderen Objekten eingehalten werden (siehe Zeichnung unten). Bitte konsultieren Sie für die Installation an einem Indoor-pool einen Installateur. Die Installation an einem windigen Ort bereitet, anders als bei einem Gas-Heizer keinerlei Probleme.

ACHTUNG: Installieren Sie das Gerät niemals in einem geschlossenen Raum mit einem begrenzten Luftvolumen, in dem die aus dem Gerät austretende Luft wiederverwendet wird, oder in der Nähe von Sträuchern, die den Lufteinlass blockieren könnten. Solche Stellen beeinträchtigen die kontinuierliche Frischluftzufuhr, was zu einem verminderten Wirkungsgrad führt und möglicherweise eine ausreichende Wärmeleistung verhindert.

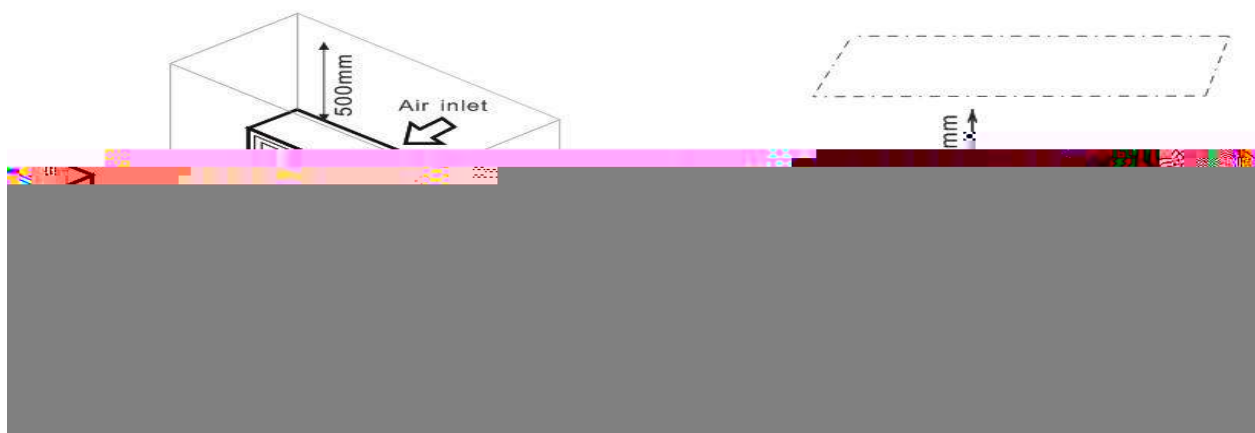

5.2 Installation eines Rückflussventils

HINWEIS

Hinweis: Wenn ein automatisches Dosiergerät für das Chlor und Säuregehalt (pH) verwendet wird, ist es wichtig, die Wärmepumpe vor zu hohen chemischen Konzentrationen, die den Wärmetauscher korrodieren könnten, zu schützen. Aus diesem Grund müssen Impfventile einer MSR-Anlage stets in der Düsenleitung nach der Wärmepumpe montiert werden. Ferner wird empfohlen, ein Rückschlagventil zu installieren, um eine Rückströmung in der Abwesenheit von Wasserzirkulation zu verhindern.

Schäden an der Wärmepumpe, die durch Nichtbeachtung dieser Vorschrift entstehen, werden nicht durch die Garantie abgedeckt.

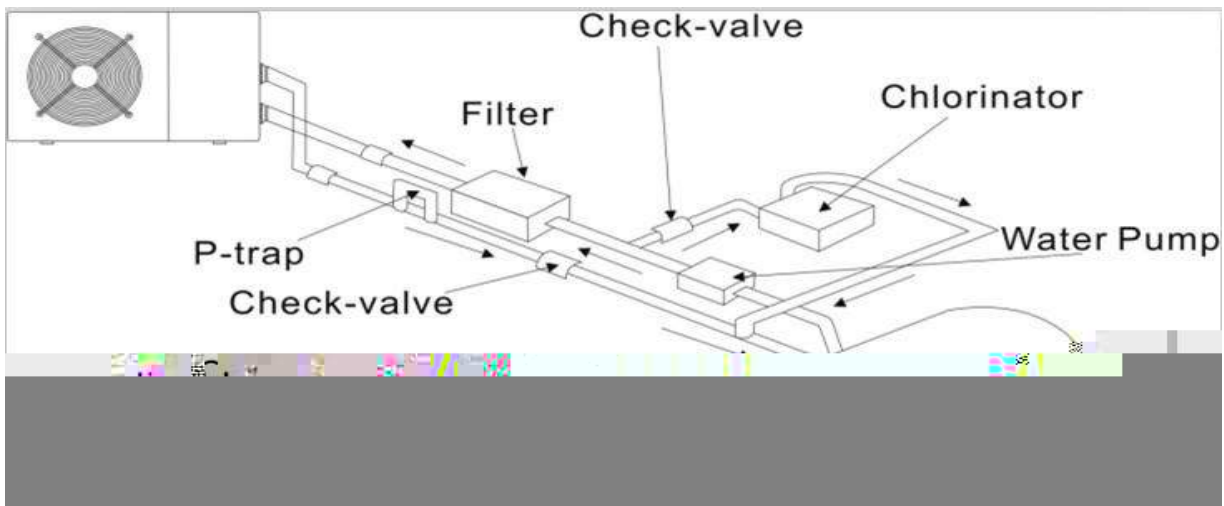

5.3 Typische Anordnung

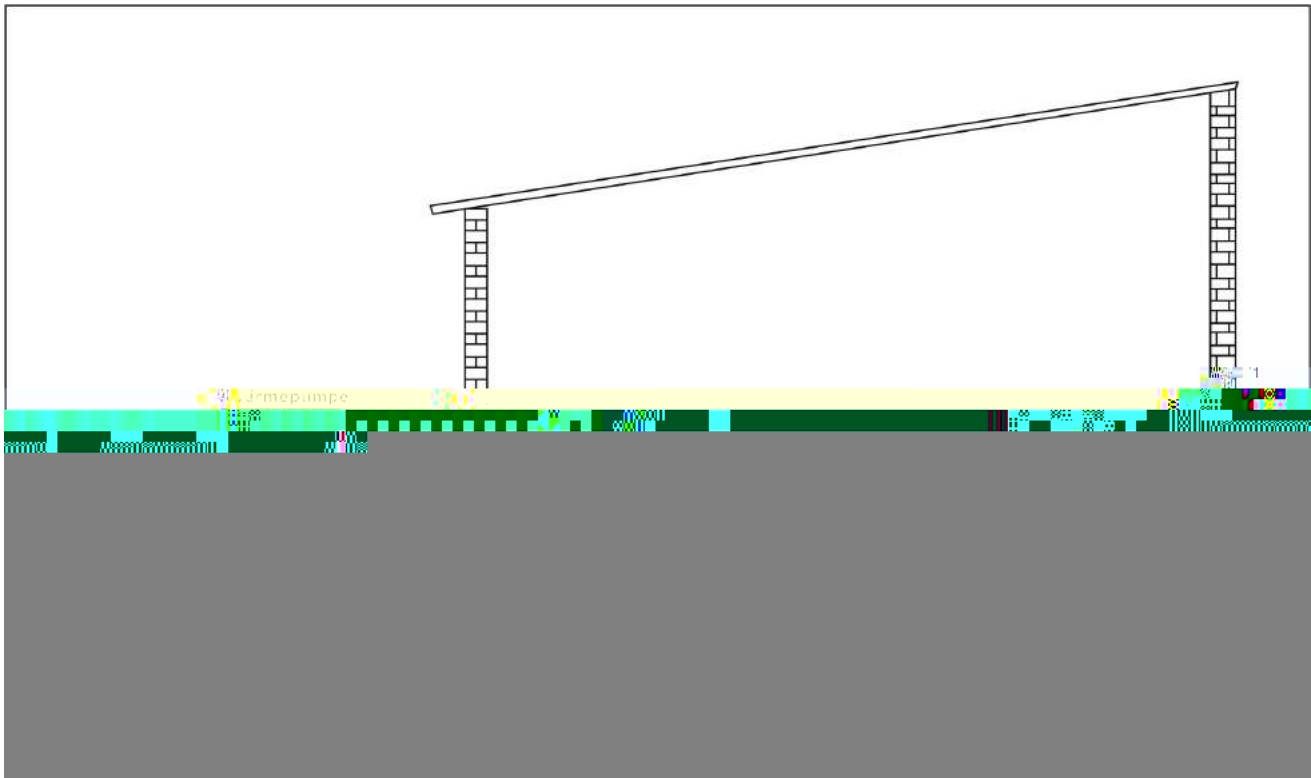

Diese Anordnung ist nur ein veranschaulichendes Beispiel.

HINWEIS

Die Fabrik liefert nur die Wärmepumpe. Alle anderen Komponenten, einschließlich einer Umgehung, falls erforderlich, müssen vom Benutzer oder vom Installationsprogramm bereitgestellt werden.

ACHTUNG:

Um das Wasser im Pool (oder Whirlpool) zu erwärmen, muss die Pumpe so betrieben werden, dass das Wasser durch die Wärmepumpe zirkuliert. Die Wärmepumpe läuft nicht an, wenn das Wasser nicht zirkuliert.

5.4 Erstinbetriebnahme

Nachdem alle Verbindungen hergestellt und geprüft sind, führen Sie die folgenden Schritte durch:

1. Schalten Sie die Filterpumpe aus. Prüfen Sie ob es ein Leck gibt, und stellen Sie sicher, dass das Wasser vom und zum Schwimmbecken fließt.
2. Schließen Sie die Wärmepumpe an ein Stromnetz an und betätigen Sie die On/Off Taste  auf dem Bedienfeld. Das Gerät startet dann nach einer bestimmten Verzögerungszeit.
3. Überprüfen Sie nach ein paar Minuten ob die herausströmende Luft schon kühler ist.
4. Beim Ausschalten der Pumpe sollte das Gerät auch automatisch.
5. Lassen Sie die Wärmepumpe und die Filterpumpe 24 Stunden am Tag laufen, bis die gewünschte Wassertemperatur erreicht ist. Die Wärmepumpe stoppt bei +1°C. Danach wird sie automatisch neu gestartet (solange die Filterpumpe läuft), wenn die Wassertemperatur im Schwimmbad um 1 Grad unter die eingestellte Temperatur fällt (z.B. wenn Sie die Temperatur auf 28°C einstellen, stoppt die Wärmepumpe bei einer Temperatur von 29°C. Sie läuft wieder an, wenn die Wassertemperatur auf 27°C sinkt.)

Je nach Ausgangstemperatur des Wassers im Schwimmbad und der Lufttemperatur, kann es mehrere Tage dauern das Wasser auf die gewünschte Temperatur zu erwärmen. Eine gute Schwimmbadabdeckung könnte die erforderliche Zeit drastisch reduzieren.

NOTIZ

Wasserdurchflussschalter:

Das Gerät ist mit einem Durchflussschalter zum Schutz der laufenden HP-Einheit bei ausreichendem Wasserdurchfluss ausgestattet. Er schaltet sich ein, wenn die Poolpumpe läuft, und schaltet sich aus, wenn sich die Pumpe abschaltet.

Zeitverzögerung - Die Wärmepumpe hat eine eingebaute 3-Minuten-Anlaufverzögerung, um die Schaltung zu schützen und übermäßigen Verschleiß der Kontakte zu vermeiden. Das Gerät startet automatisch neu, nachdem diese Zeitspanne abgelaufen ist. Selbst ein kurzer Stromausfall löst diese Zeitverzögerung aus, und verhindert so, dass das Gerät nach einem Neustart sofort wieder läuft. Zusätzliche Stromunterbrechungen während dieser Verzögerung haben keinen Einfluss auf die 3-Minuten Dauer der Verzögerung.

5.5 Kondensation

Die in die Wärmepumpe angesaugte Luft wird durch den Betrieb der Wärmepumpe zur Erwärmung des Beckenwassers gekühlt, was zu Kondensation an den Lamellen des Verdampfers führen kann.

NOTIZ

Die Kondensationsmenge kann bis zu mehreren Litern pro Stunde bei hoher relativer Feuchtigkeit betragen. Dies wird manchmal fälschlicherweise als Wasserleck aufgefasst.

5.6 Manometer Anzeige (R32)

Untersuchen Sie das Druckmessgerät, dass die Kältemittel Gasdruck von dem Gerät zeigt, die folgende Tabelle zeigt den Normalwert des Gasdrucks (R32), wenn das Gerät im ausgeschalteten oder Laufbedingungen ist.

Gerätezustand	Ausgeschaltet			
	Umgebung (°C)	-5~5	5~15	15~25
Wasser (°C)	/	/	/	/
Manometer (Mpa)	0.59~0.85	0.85~1.18	1.18~1.59	1.59~2.1

Gerätezustand	Eingeschaltet				
	Umgebung (°C)	/	/	/	/
Wasser (°C)	10~15	15~20	20~25	25~30	30~35
Manometer (Mpa)	1.1~1.6	1.3~1.8	1.5~2.1	1.7~2.4	1.9~2.7

6.1 Inverter-Schwimmbad-Wärmepumpe-Schaltplan

Ref. 71676/71677/71678/71679/71680

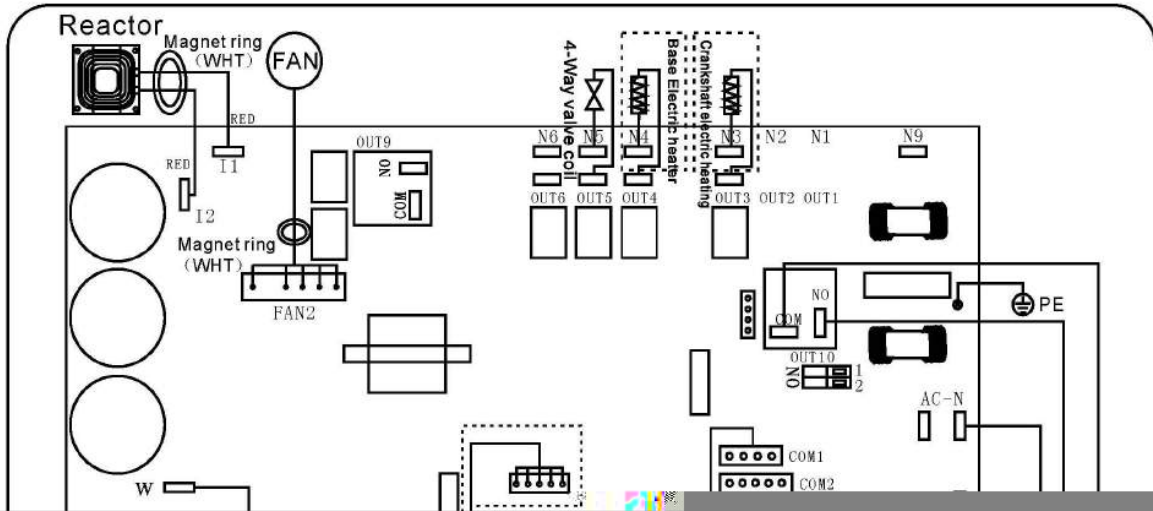

6.2 Inverter-Schwimmbad-Wärmepumpe-Schaltplan

Ref. 71681

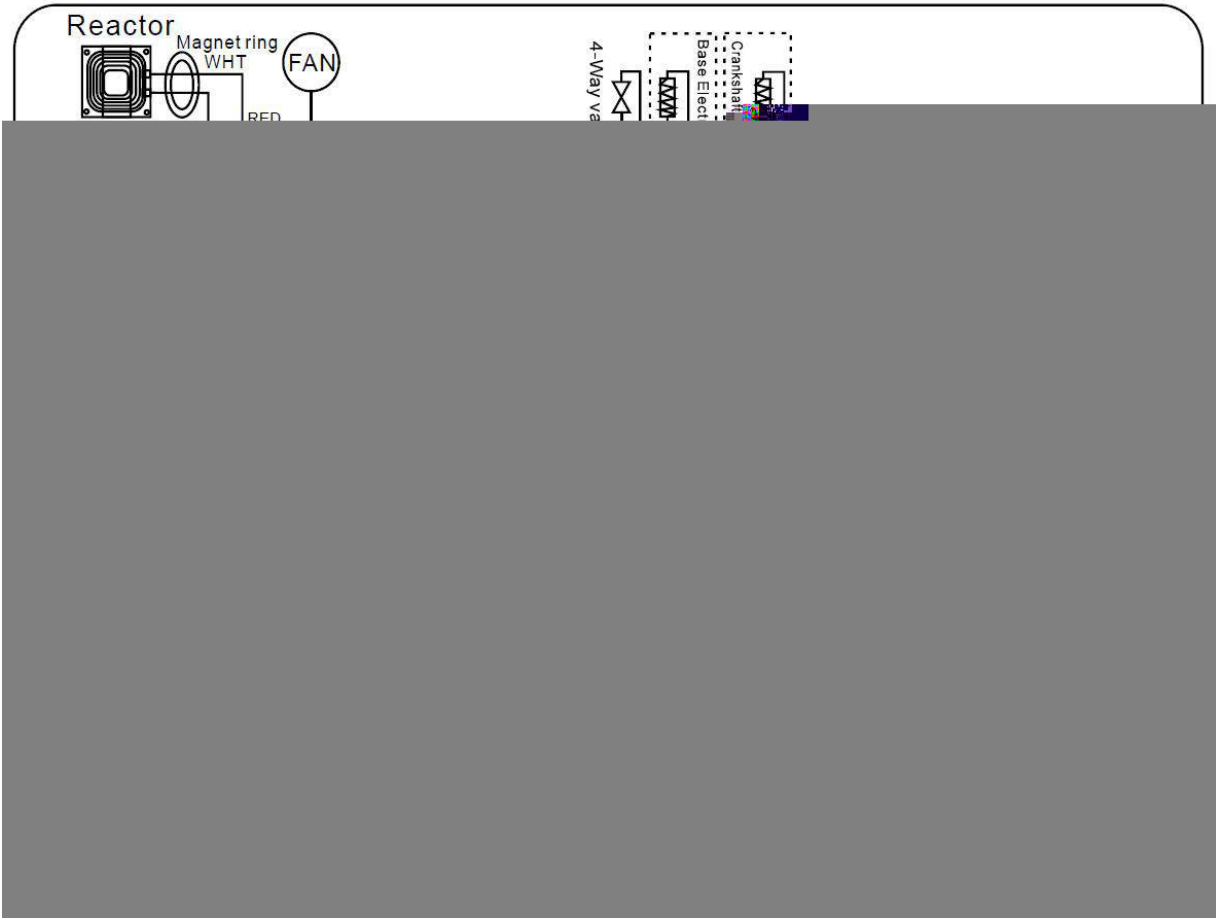

6.3 Inverter-Schwimmbad-Wärmepumpe-Schaltplan

Ref. 71682/71683

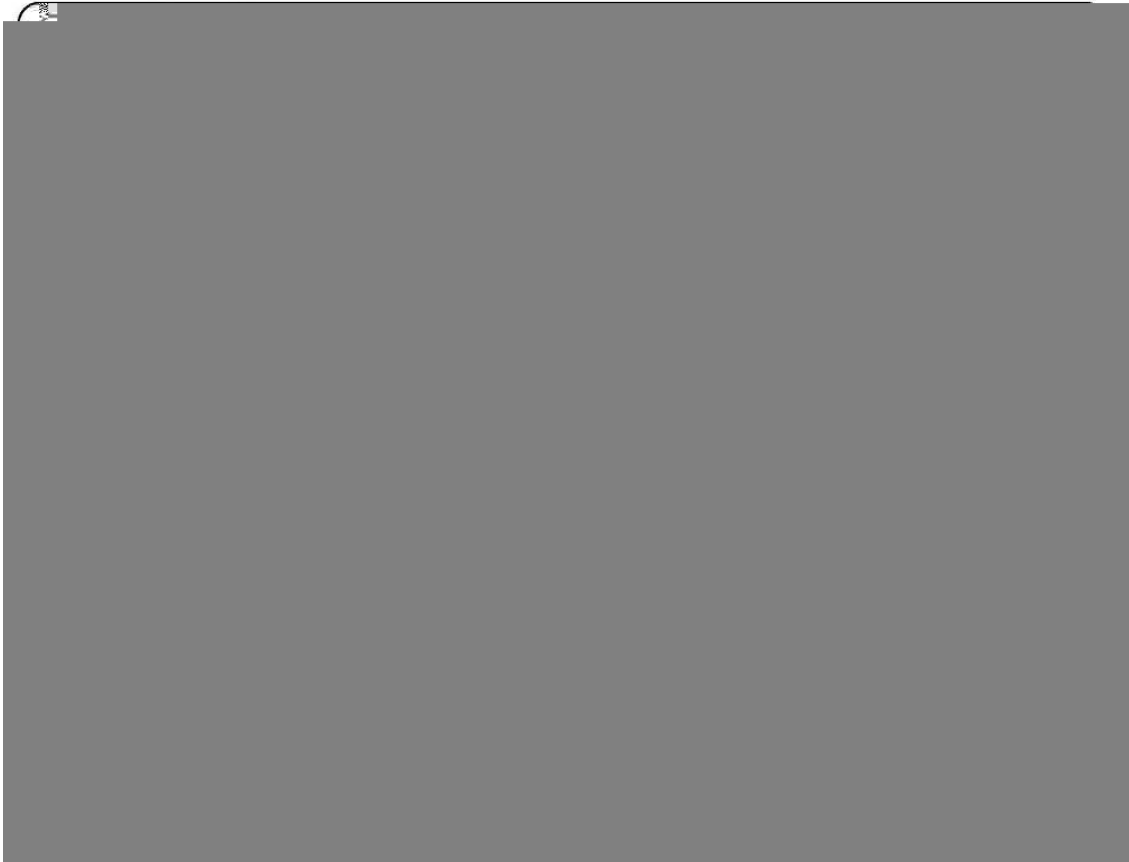

6.4 Inverter-Schwimmbad-Wärmepumpe-Schaltplan

Ref. 68822 (R410A)

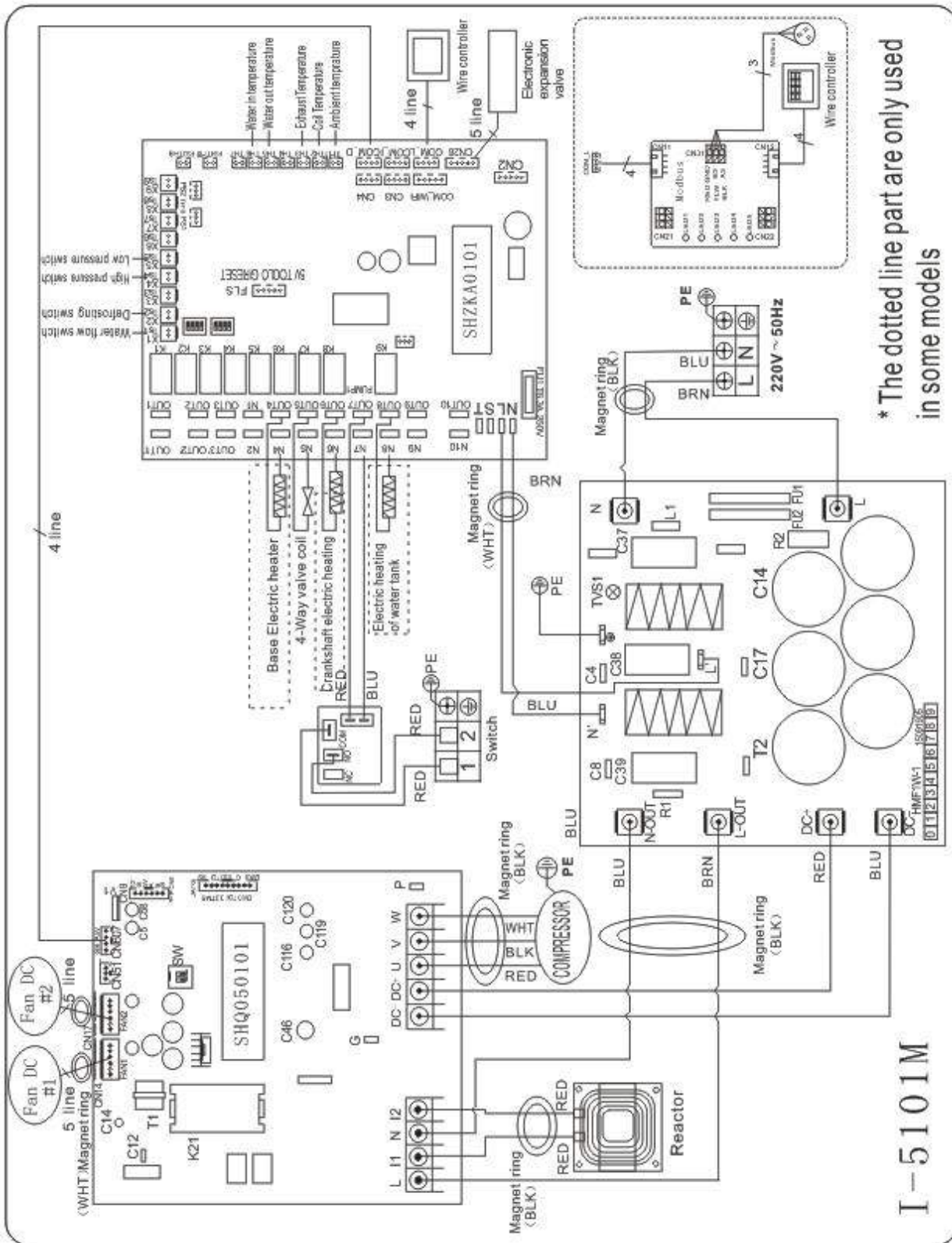

6.5 Inverter-Schwimmbad-Wärmepumpe-Schaltplan

Ref. 68821/68823 (R410A)

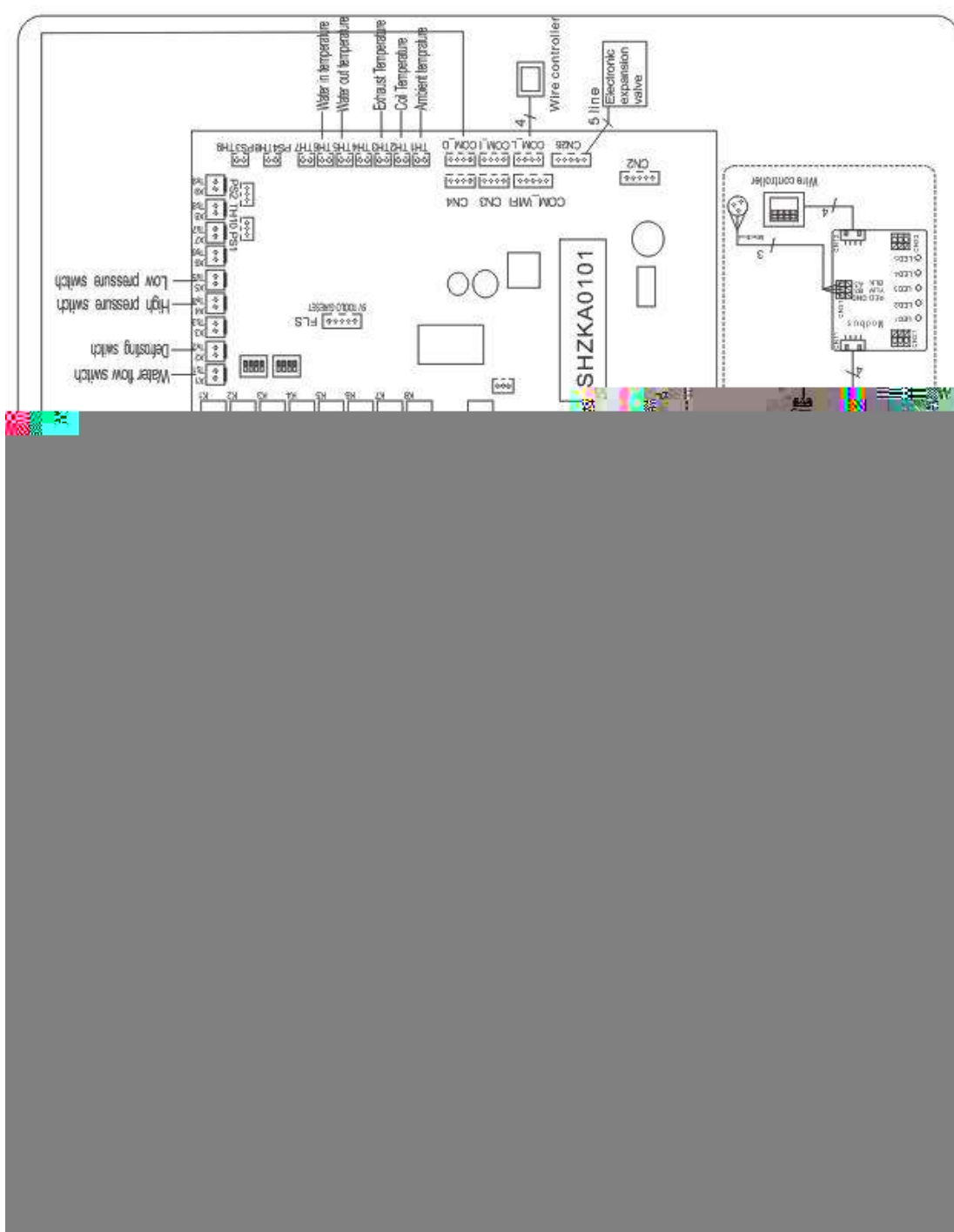

*Der obige Schaltplan dient lediglich zur Information, bitte beachten Sie den jeweiligen Schaltplan für die einzelne Maschine.

6.6 Elektrischer Anschluss

Die Stromversorgung für die Wärmepumpe muss vorzugsweise von einer ausschließlichen Schaltung mit Regelschutzkomponenten (30mA Differentialschutz) und einem magnetothermischen Schalter stammen.

- Die Elektroinstallation muss von einem Fachmann (Elektriker) gemäß den im Installationsland geltenden Normen und Vorschriften durchgeführt werden.
- Der Wärmepumpenkreis muss an der Klemmenleiste mit einem Erdungsschaltkreis verbunden sein.
- Die Kabel müssen ordnungsgemäß installiert werden, um Störungen zu vermeiden.
- Die Pumpe ist für den Anschluss an eine allgemeine Stromversorgung mit Erdanschluss vorgesehen.
- Abschnitt des Kabels; Dieser Abschnitt ist indikativ und sollte entsprechend den Bedürfnissen und Nutzungsbedingungen geprüft und angepasst werden.
- Die Toleranz der zulässigen Spannungsschwankung beträgt während des Betriebs +/- 10 %.
- Die Anschlüsse sind entsprechend der Leistung des Gerätes und des Installationszustandes zu dimensionieren.

Modelle	Leistungsschalter	Maximale Länge des Drahtes			
		2,5 mm ²	4 mm ²	6 mm ²	10 mm ²
PROELYXP07i	7 A	84 m	135 m	200 m	335 m
PROELYXP09i	9 A	57 m	90 m	130 m	225 m
PROELYXP11i	11A				
PROELYXP14i	14 A	43 m	68 m	100 m	170 m
PROELYXP16i	16 A	34 m	54 m	80 m	135 m
PROELYXP20i	20 A	29 m	45 m	66 m	110 m
PROELYXP26i	26 A	/	25 m	38 m	62 m
PROELYXP30i	35 A	/	/	22 m	36 m
PRO ELYO INVERBOOST NN 26T	9 A	15 m	35 m	49 m	81 m
PRO ELYO INVERBOOST NN 35	34 A	/	/	22 m	36 m
PRO ELYO INVERBOOST NN 35T	13 A	12 m	27 m	39 m	68 m



Diese Werte sind Richtwerte, nur der Eingriff eines autorisierten Technikers kann die Werte für Ihre Installation ermitteln.

Die elektrische Leitung muss mit einem Erdungsanschluss und einem Leistungsschalter mit einer Differenz von 30 mA ausgestattet sein.

6.7 Installation des Display-Deportierers

Foto (1)



Foto (2)



Foto (3)



Foto (4)



Foto (5)

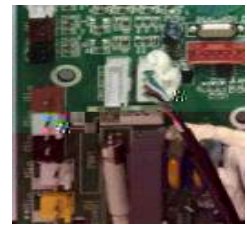

- Die Seite mit Stecker wird mit dem Bedienfeld (Foto1) verbinden
- Die andere Seite der Signalleitung (Foto 2).
- Öffnen Sie die Klemmkasten und setzen Sie die Seite ohne Stecker durch das elektrische Feld (Foto3,4).
- Stecken Sie die Verdrahtung in die dafür vorgesehene Position auf dem Modbus oder die Platine (ohne Modbus). (Foto 5)

6.8 Installation des Modbus/Fluidra Connect-Signalkabels

(6)



(7)



(8)



(9)

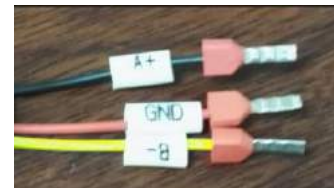

- Öffnen Sie die Klemmenabdeckung (Foto 6)
- Nehmen Sie das Modbus/Fluidra Connect -Signalkabel aus dem Zubehör (Foto 7) und stecken Sie das runde Ende des Signalkabels in die Signalkabel des Modbus/Fluidra Connect-Moduls. (Foto 8)
- Drei-Draht-Terminal: "A +", "B-", "GND", (Foto 9)

Trockenkontakt-Timeranschluss

Timer

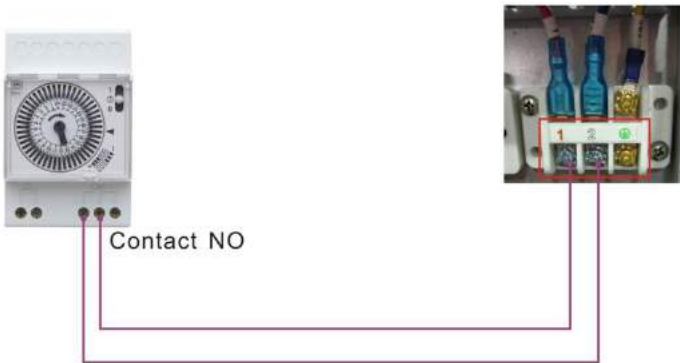

Anschluss des Pumpentrockenkontakts

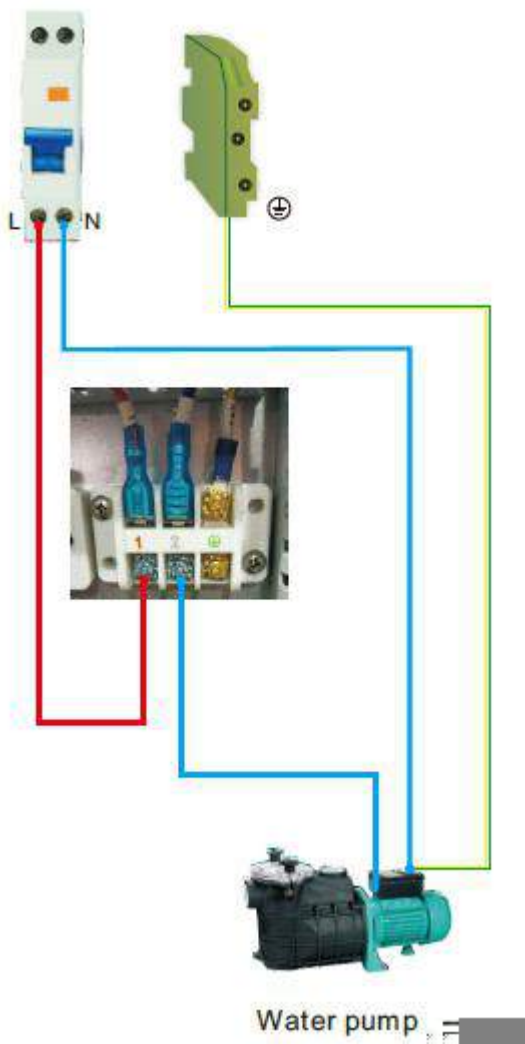

7. Steuerung der Anzeige

7.1. Betriebsanleitung

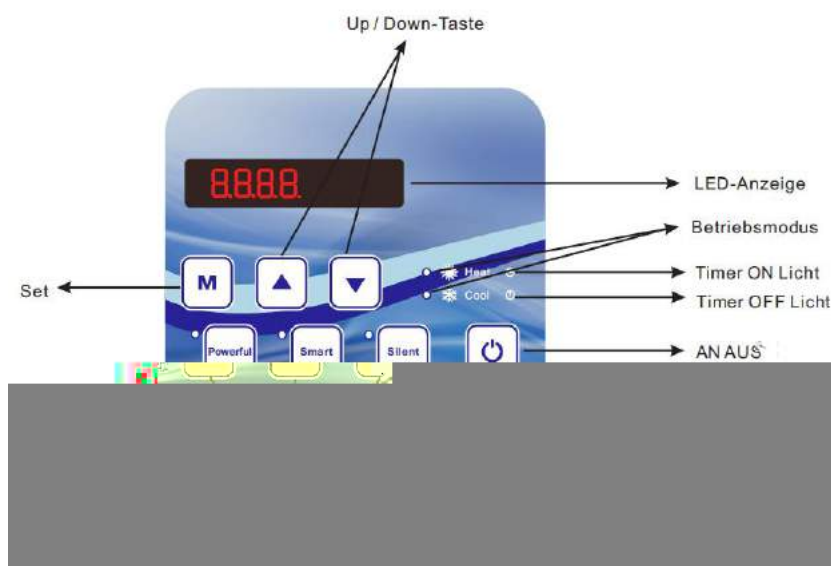

Wenn die Wärmepumpe an die Stromversorgung angeschlossen wird, zeigt die LED-Anzeige 3 Sekunden lang einen Code an, der das Wärmepumpenmodell anzeigt.

7.2 Die Tasten und ihre Bedienung

7.2.1 -Taste

Betätigen Sie , um die Wärmepumpe zu starten, zeigt die LED-Anzeige die gewünschte Wassertemperatur für 5 Sekunden, dann die Einlasswassertemperatur und den Betriebsmodus an.

Drücken Sie , um die Wärmepumpe zu stoppen und "OFF"

Achtung: Drücken Sie während der Überprüfung und Einstellung des Parameters die Taste , um die aktuelle Einstellung zu beenden und die aktuelle Einstellung zu speichern.



Drücken Sie erneut , um das Gerät ein- oder auszuschalten.

7.2.2 -Taste

Schaltet den Heizmodus und Auto-Modus.



7.2.3 Taste und

Sperrt/entsperrt die Anzeige:

Halten Sie  und  für 5 Sekunden, um die Anzeige zu sperren / zu entsperren.

Wassertemperatur: Drücken Sie  oder , um die Wassertemperatur direkt einzustellen.

Parameterprüfung:

Drücken Sie zuerst  und drücken Sie dann , um den Benutzerparameter von d0 bis d11 zu überprüfen

Code	Bedingung	Umfang	Anmerkung
d0	IPM Werkzeugtemperatur	0-120°C	Realer Prüfwert
d1	Einlaufwassertemp.	-9°C~99°C	Realer Prüfwert
d2	Auslaufwassertemp.	-9°C~99°C	Realer Prüfwert
d3	Umgebungstemperatur.	-30°C~70°C	Realer Prüfwert
d4	Frequency Begrenzungscode	0,1,2,4,8,16	Realer Prüfwert
d5	Rohrleitungstemp.	-30°C~70°C	Realer Prüfwert
d6	Abgastemperatur	0°C~C5°C (125°C)	Realer Prüfwert
d7	Schritt der EEV	0~99	N*5
d8	Betriebsfrequenz des Verdichters	0~99Hz	Realer Prüfwert
d9	Verdichterstrom	0~30A	Realer Prüfwert
d10	Aktuelle Lüfterdrehzahl	0-1200 (rpm)	Realer Prüfwert
d11	Fehlercode für das letzte Mal	Allen Fehlercode	
d12	MOBUS COM	0 - 5	Einstellung, nur Modbus
d13	MODBUS ID-Adresse	1 - 88	Einstellung, nur Modbus
d14	Produktcode	0000- FFFF	Einstellung, nur Modbus

Anmerkung:

d4:Frequenzbegrenzungscode,

0: Keine Frequenzbegrenzung;



1:Temperaturbegrenzung des Spulenrohres;

2: Überhitzungs- oder Unterkühlungsfrequenzgrenze; 4: Frequenzgrenze des Antriebsstroms;

8:Frequenzbegrenzung der Antriebsspannung;

16:Frequenzbegrenzung der Hochtemperaturfrequenz des Antriebs

7.2.4 Systemresetfunktion

Drücken Sie  und , in 10s, das System setzt zurück und zeigt "0000" auf dem Steuerpult an.

7.2.5

Symbol der Heizung, das Licht ist eingeschaltet, wenn es in Betrieb ist.

Beim Abtauen blinkt das Licht.

7.2.6

Symbol der Abkühlung, das Licht ist eingeschaltet, wenn es in Betrieb ist.

7.2.7

Symbol des automatischen Stopps, das Licht leuchtet, wenn es in Betrieb ist.

7.2.8

Symbol für automatischen Start, das Licht leuchtet, wenn es in Betrieb ist.

7.2.9

Betätigen Sie diesen Knopf, die Lampe blinkt, die Wärmepumpe arbeitet nur im vollen Ausgang.

7.2.10

Während Sie den Smart auswählen, wird die Wärmepumpe nur in „Medium Output“ und „Full Output“
Bei 'Medium Output' blinkt das Licht von Smart.

Wenn in "Full Output" die Lampe von Smart leuchtet, blinkt die Lampe Powerful.

7.2.11

Während Sie die Silent wählen, wird die Wärmepumpe nur in "Medium Output" und "Small Output"

Wenn im Modus 'Kleine Ausgabe' das Licht von Silent blinkt.

Wenn bei „Medium Output“ die Lampe von Silent leuchtet, blinkt die Lampe des Smart.

.

7.2.12 Auto-Modus

Es gibt 3 Modelle für das Gerät: Nur Heizen, Auto-Modus (Heiz- und Kühlschalter), Nur Kühlen. Sie können den Heizmodus und den Automatikmodus durch Drücken von **M** für 5 Sekunden umschalten, unabhängig davon, ob das Gerät ein- oder ausgeschaltet ist.

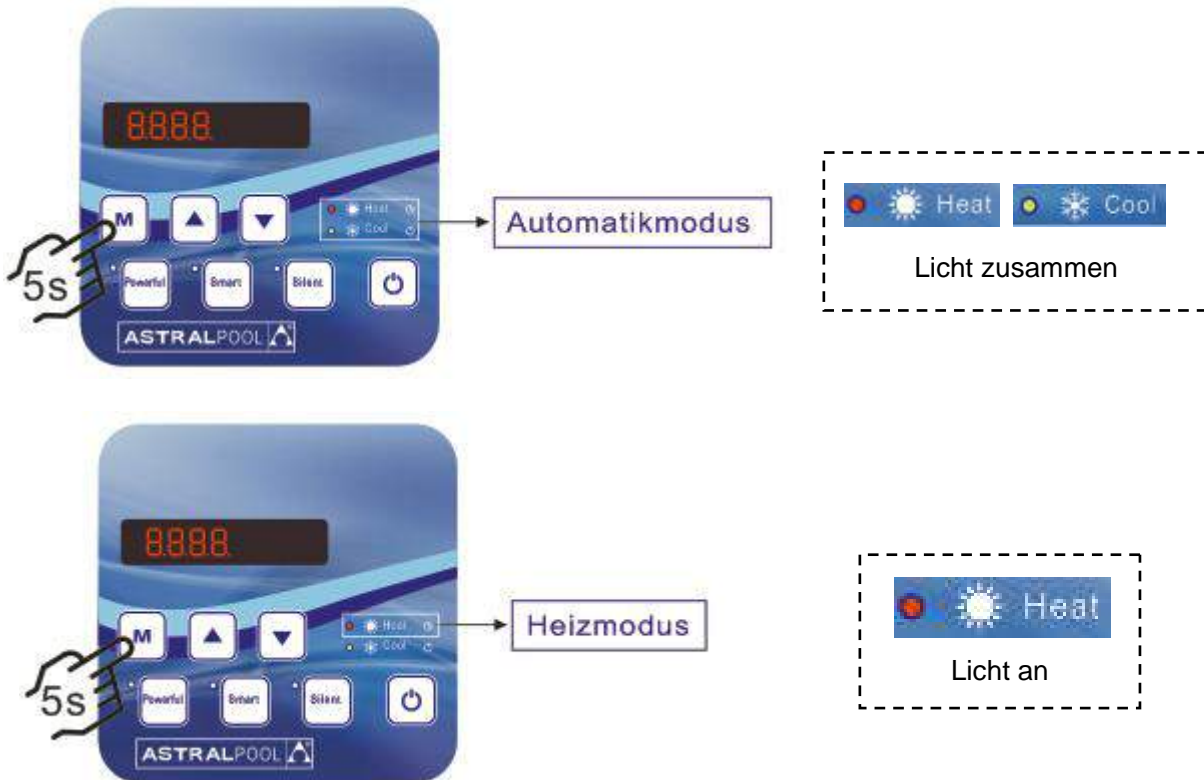

Betriebslogik des Auto-Modus

Option 1 Die Wasserpumpe ist mit dem Betrieb der Wärmepumpe zum Starten oder Stoppen verbunden.

Die Wasserpumpe startet 60s vor dem Kompressor, die Wasserpumpe startet 30s und erfasst dann den Wasserflussschalter. Wenn die Wärmepumpe in den Standby-Modus wechselt, stoppt die Wasserpumpe nach dem Stopp des Kompressors 60 Sekunden. Die Wasserpumpe wird für 3 Minuten neu gestartet und dann gestoppt, wenn die Standby-Zeit mehr als 2 Stunden beträgt.

	Bedingung	Beispiel	Funktionslogik der Wasserpumpe
Heizmodus	$T1 > T_{set} - 1$, 30 Minuten dauern	$T1 > 27^{\circ}\text{C}$, 30 Minuten dauern	Die Wasserpumpe wechselt für 2 Stunden in den Standby-Modus und startet nur außer, die Stromversorgung abzuschalten und neu zu starten. Die Wärmepumpe startet 3 Minuten nach dem Verlassen der Wasserpumpe aus dem Standby-Modus, um die Wassertemperatur T1 erneut zu ermitteln.
Kühlmodus	$T1 < T_{set} + 1$, 30 Minuten dauern	$T1 < 29^{\circ}\text{C}$, 30 Minuten dauern	Die Wasserpumpe wechselt für 2 Stunden in den Standby-Modus und startet nur außer, die Stromversorgung abzuschalten und neu zu starten. Die Wärmepumpe startet 3 Minuten nach dem Verlassen der Wasserpumpe aus dem Standby-Modus, um die Wassertemperatur T1 erneut zu ermitteln.

Option 2

Wenn die Wärmepumpe eingeschaltet ist (Betrieb oder Standby), ist die Wasserpumpe immer eingeschaltet. Nach dem manuellen Ausschalten läuft es für 1 Minute.

HINWEIS :

T_{set} = Tsetting Wassertemperatur

Zum Beispiel : $T_{set} = 28^{\circ}\text{C}$ Tsetting wassertemperatur in Ihrer Pool-Wärmepumpe

$T_{set} - 1$ = less 1°C than Tsetting temperatur

$T_{set} - 1 = 28 - 1 = 27^{\circ}\text{C}$

$T_{set} + 1$ = more 1°C than Tsetting temperatur

$T_{set} + 1 = 28 + 1 = 29^{\circ}\text{C}$

7.3 Heizungslogik

Arbeits status		Arbeitsmodus	Wasser in der Temperatur-T1	Zum Beispiel, Wasser in der Temperatur-T1	Arbeitsniveau der Wärmepumpe
1	Inbetriebnahme der Wärmepumpe	Wenn Sie den "Smart-Arbeitsmodus" wählen	$T1 < Tset-1$	$T1 < 27^{\circ}C$	Powerful mode-Frequenz F9
2			$Tset-1 \cong T1 < Tset$	$27^{\circ}C \cong T1 < 28^{\circ}C$	Frequenz: F9 -F8-F7,...,-F2
3			$Tset \cong T1 < Tset+ 1$	$28^{\circ}C \cong T1 < 29^{\circ}C$	Silent mode-frequency F2
4			$T1 \cong Tset+1$	$T1 \cong 29^{\circ}C$	HP wird Standby sein, aufhören zu arbeiten, bis die Wassertemperatur auf weniger als $28^{\circ}C$ fällt.
5		Wenn Sie den "Stillen Arbeitsmodus" wählen.	$T1 < Tset$	$T1 < 28^{\circ}C$	Smart mode -Frequenz F5.
6			$Tset \cong T1 < Tset+1$	$28^{\circ}C \cong T1 < 29^{\circ}C$	Silent mode-Frequenz F2/F1.
7			$T1 \cong Tset+1$	$T1 \cong 29^{\circ}C$	HP wird Standby sein, aufhören zu arbeiten, bis die Wassertemperatur auf weniger als $28^{\circ}C$ fällt.
8		Wenn Sie den "Leistungsfähigen Arbeitsmodus" auswählen.	$T1 < Tset+1$	$T1 < 29^{\circ}C$	Powerful mode-Frequenz F10/F9
9			$T1 \cong Tset+1$	$T1 \cong 29^{\circ}C$	HP wird Standby sein, aufhören zu arbeiten, bis die Wassertemperatur auf weniger als $28^{\circ}C$ fällt.
10	Starten Sie erneut, um Wasser im Standby-Status zu erhitzen	Wenn HP im "Smart-Modus" arbeitet	$T1 \cong Tset$	$T1 \cong 28^{\circ}C$	Standby
11			$Tset > T1 \cong Tset-1$	$28^{\circ}C > T1 \cong 27^{\circ}C$	Silent-frequenz F2
12			$Tset-1 > T1 \cong Tset-2$	$27^{\circ}C > T1 \cong 26^{\circ}C$	Frequenz: F2 -F3-F4,...,-F9
13			$< Tset-2$	$< 26^{\circ}C$	Powerful-frequenz F9
14		Wenn HP im "Silent Mode" arbeitet	$\cong Tset$	$\cong 28^{\circ}C$	Standby
15			$Tset > T1 \cong Tset-1$	$28^{\circ}C > T1 \cong 27^{\circ}C$	Silent mode-frequenz F2/F1
16			$T1 < Tset-1$	$T1 < 27^{\circ}C$	Smart -frequenz F5
17	Wenn HP im "Leistungsstarken Modus" arbeitet	$T1 < Tset-1$	$T1 < 27^{\circ}C$	Powerful -frequenz F10/F9	

7.4 Kühllogik

Arbeits status		Arbeitsmodus	Wasser in der Temperatur-T1	Zum Beispiel, Wasser in der Temperatur-T1	Arbeitsniveau der Wärmepumpe
1	Inbetriebnahme der Wärmepumpe	Wenn Sie den "Smart-Arbeitsmodus" wählen	$T1 \leq Tset-1$	$T1 \leq 27^{\circ}C$	Standby.
2			$Tset-1 < T1 \leq Tset$	$27^{\circ}C < T1 \leq 28^{\circ}C$	Silent mode-Frequenz F2
3			$Tset < T1 \leq Tset+1$	$28 < T1 \leq 29^{\circ}C$	Frequenz: F9 -F8-F7,...,- F2
4			$T1 \geq Tset+1$	$T1 \geq 29^{\circ}C$	Powerful mode-F9
5		Wenn Sie den "Stillen Arbeitsmodus" wählen	$T1 \leq Tset-1$	$\leq 27^{\circ}C$	Standby
6			$Tset-1 < T1 \leq Tset$	$27^{\circ}C < T1 \leq 28^{\circ}C$	Silent mode - frequenz F2/F1
7			$T1 > Tset$	$T1 > 28^{\circ}C$	Smart mode -frequenz F5
8		Wenn Sie den "Leistungsfähigen Arbeitsmodus" auswählen.	$T1 > Tset-1$	$T1 > 27^{\circ}C$	Powerful mode-frequenz F10/F9
9			$T1 \leq Tset-1$	$T1 \leq 27^{\circ}C$	Standby
10	Starten Sie erneut das Kühlen des Wassers im Standby-Modus	Smart	$T1 \leq Tset-1$	$T1 \leq 27^{\circ}C$	Standby
11			$Tset \leq T1 < Tset+1$	$28 \leq T1 < 29^{\circ}C$	Silent- frequenz F2
12			$Tset+1 \leq T1 < Tset+2$	$29 \leq T1 < 30^{\circ}C$	Frequenz: F2 -F3-F4,...,- F9
13			$T1 \geq Tset+2$	$T1 \geq 30^{\circ}C$	Powerful mode -frequenz F9
14		Silent	$Tset < T1 \leq Tset+1$	$28 < T1 \leq 29^{\circ}C$	Silent mode-frequenz F2/F1
15			$T1 > Tset+1$	$T1 > 29^{\circ}C$	Smart mode-frequenz F5
16		Powerful	$T1 > Tset+1$	$T1 > 29^{\circ}C$	Powerful mode-frequenz F10/F9
17	$T1 \leq Tset-1$		$T1 \leq 27^{\circ}C$	Standby	

8.1 Fehlercode Anzeige auf dem LED-Display

Fehlfunktion	Fehlercode	Grund	Lösung
Fehler beim Sensor für den Heizkondensator T1-TH6	PP 01	1.Sensorfehler oder Kurzschluss 2.Die Verdrahtung des Sensors ist lose	1. Die Verdrahtung der Sensoren reparieren 2.Schalten Sie den Sensor
Fehler beim Sensor für den Gasrücklauf T2-TH5	PP 02	1.Sensorfehler oder Kurzschluss 2.Die Verdrahtung des Sensors ist lose	1. Die Verdrahtung der Sensoren reparieren 2.Schalten Sie den Sensor
Fehler beim Sensor für die Umgebungstemperatur T3-TH2	PP 03	1.Sensorfehler oder Kurzschluss 2.Die Verdrahtung des Sensors ist lose	1. Die Verdrahtung der Sensoren reparieren 2.Schalten Sie den Sensor
Gasrücklaufsensorausfall	PP 04	1.Sensorfehler oder Kurzschluss 2.Die Verdrahtung des Sensors ist lose	1. Die Verdrahtung der Sensoren reparieren 2.Schalten Sie den Sensor
Frostschutz im Winter T5-TH1	PP 05	1.Sensorfehler oder Kurzschluss 2.Die Verdrahtung des Sensors ist lose	1. Die Verdrahtung der Sensoren reparieren 2.Schalten Sie den Sensor
Ausfall des Auspuffrohrsensors T6-TH3	PP 06	1.Sensorfehler oder Kurzschluss 2.Die Verdrahtung des Sensors ist lose	1. Die Verdrahtung der Sensoren reparieren 2.Schalten Sie den Sensor
Frostschutz im Winter	PP 07	Die Umgebungstemperatur oder die Wassereintrittstemperatur ist zu niedrig	Normaler Schutz
Niedriger Umgebungstemperaturschutz	PP 08	1.Geben Sie den Umfang der Nutzung der Umgebung 2.Sensor Anomalie	1.Stop verwenden, über den Umfang der Verwendung 2.Schalten Sie den Sensor
Rohrtemperatur zu hoch im Kühlbetrieb T3-TH2	PP 10	1. Ambient Temperatur ist zu hoch oder die Wassertemperatur ist zu hoch im Kühlmodus 2. Kälteanlage ist abnormal	1. Überprüfen Sie den Umfang der Verwendung 2.Kälteanlage prüfen
Wassertemperatur (T2-TH5) zu niedriger Schutz im Kühlmodus	PP 11	1. Low Wasserfluss 2. T2-TH5 Temperatursensor abnormal	1. Wasserpumpe und Wasserstraßensystem prüfen 2. Tauschen T2-TH5 Temperatursensor

Fehlfunktion	Fehlercode	Grund	Lösung
Hochdruckversagen TS4	EE 01	<ol style="list-style-type: none"> 1.Hochdruckschalter in schlechtem Anschluss oder Ausfall 2.Umgebungs- Temperatur ist zu hoch 3.Wassertemperatur ist zu hoch 4.Wasserfluss ist zu niedrig 5.Fan Motordrehzahl ist abnormal oder Ventilatormotor hat beschädigt 	<ol style="list-style-type: none"> 1. Überprüfen Sie die Verdrahtung auf einen Hochdruckschalter oder ändern Sie eine neue 2. Überprüfen Sie den Wasserfluss oder die Wasserpumpe 3. Ventilator prüfen 4. Das Rohrleitungssystem prüfen und reparieren
Niederdruckversagen TS5	EE 02	<ol style="list-style-type: none"> 1. Niederdruckschalter bei schlechtem Anschluss oder Ausfall 2.EEV ist blockiert oder Rohrsystem ist gestaut 3.Motorgeschwindigkeit ist abnormal oder Motor hat beschädigt 4.Gas Leckage 	<ol style="list-style-type: none"> 1. Die Verdrahtung auf Niederdruck prüfen oder eine neue ändern 2.Verwenden Sie die EEV und das Rohrleitungssystem Motor prüfen 3. Durch das Hochdruckmessgerät zur Überprüfung des Druckwertes
Kein Wasserfluss oder Wasserflussschalteausfall TS1	EE 03	<ol style="list-style-type: none"> 1.Wasser-Flow-Schalter hat keinen Kontakt 2.Wasserstromschalter ist beschädigt 3.Kein bzw. Unzureichender 	<ol style="list-style-type: none"> 1. Die Verdrahtung für den Wasserstromschalter prüfen 2.Wählen Sie den Wasserflussschalter 3.Check die Wasserpumpe oder die Wasserstraße System
Überheizungsschutz für Wassertemperatur (T2-TH5) im Heizbetrieb	EE 04	<ol style="list-style-type: none"> 1.Geringer Wasserfluss 2.Wasser-Flow-Schalter ist fest und die Wasserversorgung ist abgeschnitten 3. T2-TH5-Sensor ist 	<ol style="list-style-type: none"> 1.Prüfen Sie das Rohrleitungssystem 2. Filterpumpe oder Wasserstromschalter prüfen 3. T2-TH5-Sensor prüfen oder einen anderen ändern
Abgastemperatur (T6-TH3) zu hoher Schutz	EE 05	<ol style="list-style-type: none"> 1. Gasundichtigkeit 2.Geringer Wasserfluss 3.Rohrleitungssystem wurde blockiert 4.Auslasstemperatur Sensorfehler 	<ol style="list-style-type: none"> 1. Überprüfen Sie das Hochdruckmanometer, wenn es zu niedrig ist, füllen Sie es mit etwas Gas 2. Überprüfen Sie das Rohrleitungssystem und die Filterpumpe 3.Überprüfen Sie das Rohrleitungssystem, wenn es einen Blockade gab 4. Ändern Sie einen neuenAbgastempersensor

Fehlfunktion	Fehlercode	Grund	Lösung
Reglerfehler oder Kommunikationsfehler	EE 06	<ol style="list-style-type: none"> 1. Drahtverbindung ist nicht gut oder beschädigter Signaldraht 2. Controller fehler 	<ol style="list-style-type: none"> 1. Überprüfen und wieder anschließen der Signalleitung 2. Montieren Sie ein neues Signalkabel 3. Stromversorgung abschalten und Maschine neu starten 4. Ändern eines neuen Controllers
Kompressorstromschutz	EE 07	<ol style="list-style-type: none"> 1. Der Kompressorstrom ist zu groß momentan 2. Falscher Anschluss für Kompressor-Phasenfolge 3. Kompressor Ansammlungen von Flüssigkeit und Öl führen zum Strom wird größer 4. Kompressor oder Fahrerboard beschädigt 5. Die Wasserströmung ist abnormal 6. Kraftschwankungen innerhalb kurzer Zeit 	<ol style="list-style-type: none"> 1. Kompressor prüfen 2. Überprüfen Sie die Rohrleitung 3. Überprüfen Sie, ob die Stromversorgung im normalen Bereich erfolgt 4. Überprüfen Sie die Phasenfolgeverbindung
Kommunikationsfehler zwischen der Steuerung und der Hauptplatine	EE 08	<ol style="list-style-type: none"> 1. Poor-Signalleitung oder beschädigte Signalleitung 2. Controller-Störung 	<ol style="list-style-type: none"> 1. Überprüfen und wieder anschließen der Signalleitung 2. Montieren Sie ein neues Signaldraht 3. Stromversorgung abschalten und Maschine neu starten 4. Ändern eines neuen Controllers
Kommunikationsfehler zwischen Hauptplatine und Treiberplatine	EE 09	<ol style="list-style-type: none"> 1. Anschluss der Verbindung Draht 2. Der Draht ist beschädigt 	<ol style="list-style-type: none"> 1. Drücken Sie den Drahtanschluss 2. Keile einen neuen Draht
VDC-Spannung zu hoher Schutz	EE 10	<ol style="list-style-type: none"> 1. An der Hauptplatine ist die Netzspannung zu hoch 2. Driver Bord ist beschädigt. 	<ol style="list-style-type: none"> 1. Überprüfen Sie, ob die Stromversorgung im normalen Bereich liegt 2. Fahren Sie an Bord oder Hauptplatine
Schutz der IPM-Module	EE 11	<ol style="list-style-type: none"> 1. Datenfehler 2. Krong Verdichterphasenanschluss 3. Kompressor Flüssigkeit und Öl Anhäufung führen zum Strom wird größer 4. Kompressor oder Fahrerboard beschädigt 	<ol style="list-style-type: none"> 1. Programmfehler, Stromversorgung abschalten und nach 3 Minuten neu starten 2. Fahren Sie mit dem Fahrerboard 3. Kompressor-Sequenzverbindung prüfen

Fehlfunktion	Fehlercode	Grund	Lösung
VDC-Spannung zu wenig Schutz	EE 12	<ol style="list-style-type: none"> 1. Mother Netzspannung ist zu niedrig 2. Driver Bord ist beschädigt. 	<ol style="list-style-type: none"> 1. Prüfen Sie, ob die Stromversorgung im normalen Bereich liegt 2. Fahrertreiber wechseln
Eingangsstrom über hohen Schutz.	EE 13	<ol style="list-style-type: none"> 1. Der Kompressorstrom ist zu groß momentan 2. Die Wasserströmung ist abnormal 3. Kraftschwankungen innerhalb kurzer Zeit 4. Wrong PFC Induktivität 	<ol style="list-style-type: none"> 1. Kompressor prüfen 2. Überprüfen Sie die Wasserstraße 3. Überprüfen Sie, ob die Stromversorgung im normalen Bereich liegt 4. Überprüfen Sie, ob die korrekte PFC-Induktivität verwendet wird
Der thermische Schaltkreis des IPM-Moduls ist abnormal	EE 14	<ol style="list-style-type: none"> 1. Ausgang Abnormität der IPM-Modul thermischen Kreislauf Motor 2. Lüfter ist funktionslos oder beschädigt 3. Lüfterflügel ist gebrochen 	<ol style="list-style-type: none"> 1. Fahren Sie eine Fahrerkarte 2. Überprüfen Sie, ob die Motordrehzahl zu niedrig ist oder der Lüftermotor beschädigt ist, ändern Sie einen anderen 3. Montieren Sie ein neues Lüfterrad
Die Temperatur des IPM-Moduls ist zu hoch	EE 15	<ol style="list-style-type: none"> 1. Ausfahrt Ausnahme des IPM-Modul-Thermo-Schaltkreises 2. Motor ist abnormal oder beschädigt 3. Lüfterflügel ist gebrochen 	<ol style="list-style-type: none"> 1. Fahren Sie eine Fahrerkarte 2. Überprüfen Sie, ob die Lüftermotordrehzahl zu niedrig ist oder der Lüftermotor beschädigt ist, ändern Sie einen anderen 3. Montieren Sie ein neues Lüfterrad
PFC-Modulschutz	EE 16	<ol style="list-style-type: none"> 1. Ausgang Ausnahme des PFC-Moduls 2. Motor ist abnormal oder beschädigt 3. Fan Klinge ist gebrochen 4. Input Spannungssprung, Eingangsleistung ist abnormal 	<ol style="list-style-type: none"> 1. Fahren Sie eine Fahrerkarte 2. Überprüfen Sie, ob die Motordrehzahl zu niedrig ist oder der Lüftermotor beschädigt ist, ändern Sie einen anderen 3. Klappen Sie ein anderes Lüfterblatt 4. Überprüfen Sie die Eingangsspannung
DC-Lüftermotorausfall	EE 17	<ol style="list-style-type: none"> 1. DC Motor ist beschädigt 2. Hauptplatine beschädigt 3. Das Lüfterrad ist fest 	<ol style="list-style-type: none"> 1. Detect DC-Motor, ersetzen durch eine neue 2. Montieren Sie eine neue Hauptplatine 3. Versuchen Sie dieses wieder zu lösen (Leichtgängigkeit herstellen)

Fehlfunktion	Fehlercode	Grund	Lösung
Der thermische Schaltkreis des PFC-Moduls ist abnormal	EE 18	Das Fahrer Brett ist beschädigt	<ol style="list-style-type: none"> 1. Erfahren Sie eine neue Treiber-Board 2. Überprüfen Sie, ob die Lüftermotordrehzahl zu niedrig ist oder der Lüftermotor beschädigt ist, ändern Sie einen anderen
PFC-Modul Hochtemperaturschutz	EE 19	<ol style="list-style-type: none"> 1. PFC Modul thermische Schaltung Ausgang anormal 2. Motor ist abnormal oder beschädigt 3. Lüfterflügel ist gebrochen 4. Die Schraube im Fahrer Brett ist nicht fest 	<ol style="list-style-type: none"> 1. Erfahren Sie eine neue Treiber-Board 2. Überprüfen Sie, ob die Motordrehzahl zu niedrig ist oder der Lüftermotor beschädigt ist, ändern Sie einen anderen 3. Montieren Sie ein neues Lüfterrad 4. Überprüfen Sie, ob die Schraube locker ist
Der Eingangsstromausfall	EE 20	Die Versorgungsspannung schwankt zu stark	Überprüfen Sie, ob die Spannung stabil ist
Software-Steuer ausnahme	EE 21	<ol style="list-style-type: none"> 1. Kompressor läuft aus dem Schritt 2. Wrong Programm 3. Impurity im Kompressor verursacht die instabile Drehzahl 	<ol style="list-style-type: none"> 1. Überprüfen Sie die Hauptplatine oder ändern Sie eine neue 2. Geben Sie das richtige Programm ein
Stromdetektor ausfall	EE 22	<ol style="list-style-type: none"> 1. Spannungssignal abnormal 2. Driver Board ist beschädigt 	<ol style="list-style-type: none"> 1. Überprüfen Sie die Hauptplatine oder ändern Sie eine neue 2. Change eine neue Treiber-Board
Kompressorstart fehlgeschlagen	EE 23	<ol style="list-style-type: none"> 1. Main Board ist beschädigt 2. Kompressor Verdrahtungsfehler oder schlechter Kontakt oder unverbunden 3. Flüssigkeitsansammlung innen 4. Wrong Phasenanschluss für Kompressor 	<ol style="list-style-type: none"> 1. Überprüfen Sie die Hauptplatine oder ändern Sie eine neue 2. Die Verdichterverdrahtung gemäß Schaltplan prüfen <p>Prüfen Sie den Kompressor oder ändern Sie einen neuen</p>

Fehlfunktion	Fehlercode	Grund	Lösung
Umgebungs-Temperatur-Geräte-Fehler auf Treiber-Board	EE 24	Störung der Umgebungstemperatur	Fahrertreiber oder Hauptplatine wechseln
Kompressorphasenversagen	EE 25	Die Kompressoren U, V, W sind mit einer Phase oder zwei Phasen verbunden	Überprüfen Sie die tatsächliche Verdrahtung gemäß Schaltplan
4-Wege-Ventilumkehrversagen	EE 26	1. Das 4-Wege-Ventil ist defekt 2. Lack Kältemittel (keine Erkennung, wenn T3-TH2 oder T5-TH1 Störung)	1. Schalten Sie den Kühlmodus, um das 4-Wege-Ventil zu überprüfen, wenn es richtig umgekehrt wurde 2. Montieren Sie ein neues 4-Wege-Ventil 3. Füllen Sie das System mit Gas
lesen Fehlfunktion von EEPROM-Daten	EE 27	1. Falsche EEPROM Daten im Programm oder fehlgeschlagene Eingabe von EEPROM Daten 2. Main Board Ausfall	1. Geben Sie korrekte EEPROM-Daten ein 2. Change eine neue Hauptplatine
Der Inter-Chip-Kommunikationsfehler auf der Hauptsteuerplatine	EE 28	Hauptplatine ausgefallen	1. Die Stromversorgung abschalten und neu starten 2. Montieren Sie eine neue Hauptplatine

Bemerkungen:

1. Wenn im Heizmodus die Wasseraustrittstemperatur höher als die eingestellte Temperatur über 7 ° C ist, zeigt der LED-Controller EE04 für den Wasserüberhitzungsschutz an.
2. Wenn im Kühlmodus die Wasseraustrittstemperatur niedriger als die eingestellte Temperatur über 7 ° C ist, zeigt der LED-Controller PP11 für den Wasserüberkühlungsschutz an.

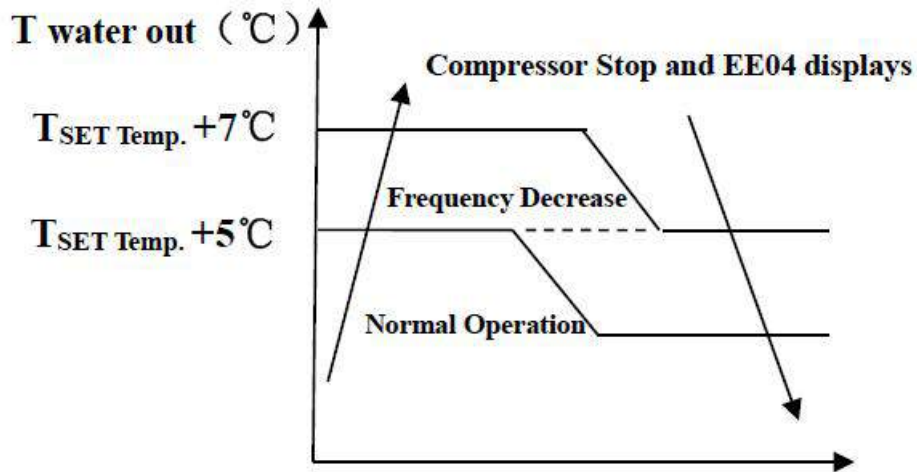

EE04 Wasserüberhitzungsschutz

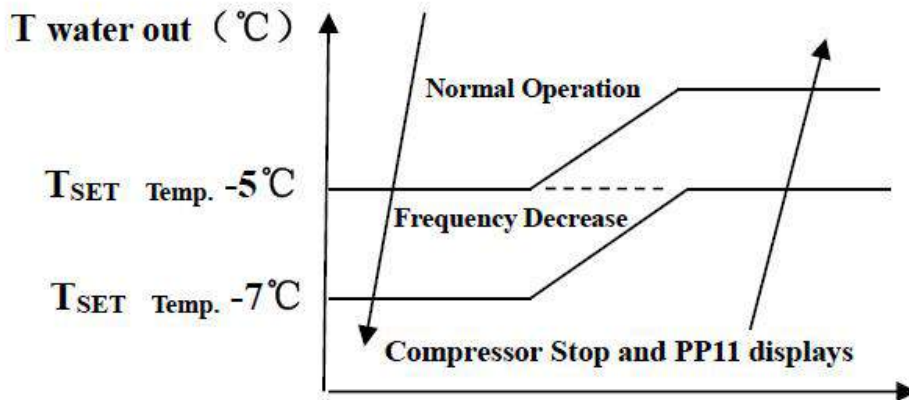

PP11 Wasserüberkühlung Schutz

Zum Beispiel wie unten:

Modus	Wasseraustrittst emperatur	Temperatur einstellen	Bedingung	Fehlfunktion
Heizmodus	36°C	29°C	$T_{out} - T_{set} \geq 7^{\circ}C$	EE04 Überhitzungsschutz für Wassertemperatur (T2)
Kühlmodus	23°C	30°C	$T_{set} - T_{out} \geq 7^{\circ}C$	PP11 zu niedriger Schutz für die Wassertemperatur (T2)

8.2 Andere Fehlfunktionen und ihre Lösung (werden nicht auf der LED-Kabelsteuerung angezeigt)

Fehlfunktion	Anzeichen	Ursachen	Lösung
	LED-Kabelsteuerung hat keine Anzeige LED-Kabelsteuerung zeigt die a e	Keine Stromzufuhr	Überprüfen Sie ob Kabel und Schutzschalter verbunden sind

Wärmepumpe
läuft nicht

9.1 Explosionszeichnung Modell: 71676

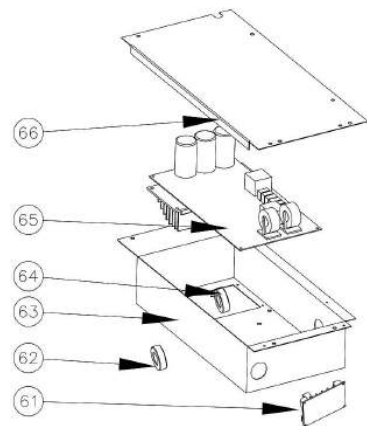
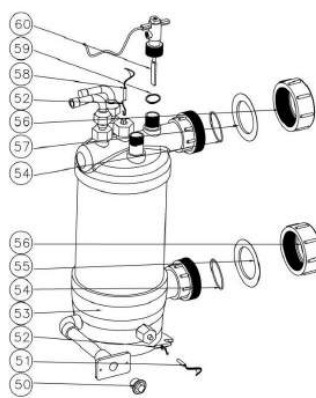
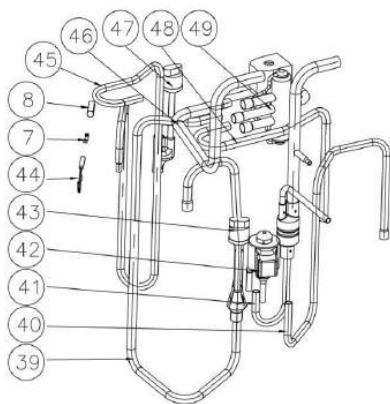
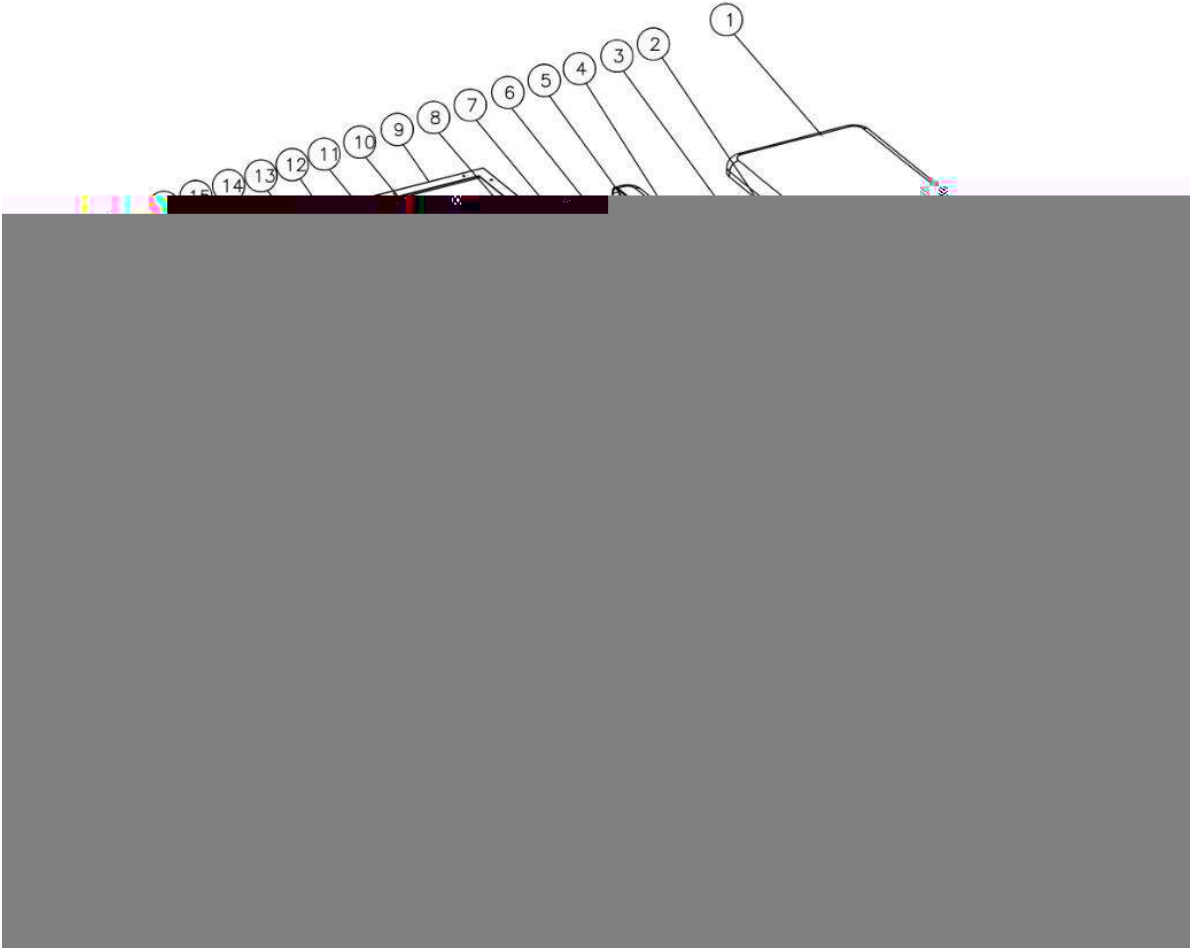

9.2 Ersatzteilliste

Modell: 71676

NO	ERP	Teile Name	NO	ERP	Teile Name
1	1330900291	Obere Abdeckung	34	117020180	Regler
2	117110020	Umgebungstemp. Sensor T5-TH1	35	103000227	Kollektive Rohrleitungen
3	133020010	Umgebungstemp. Sensorclip	36	136020018	Gummi
4	1330900271	Rückseite	37	103000227	Verteilungsrohrleitung
5	103000227	Verdampfer	38	106000011	Druckanzeige
6	117110004	Rohrtemp. Sensor T3-TH2	39	113020320	Gasrückführung
7	113190001	Sensorgehäuseleitung	40	113080074	EEV zu Verteilungsrohrleitungen
8	113190001	Clip	41	113070042	Austauscher zu EEV
9	108110038	Oberer Rahmen	42	119000017	EEV
10	108050073	Isolationsplatte	43	116000071	Niederdruckschalter
11	108110043	Lüftermotorhalterung	44	117110021	Abgastemp. Sensor T6-TH3
12	142000058	Verdampfer-Heizband	45	113010229	Auspuff
13	108480015	Gurtfixierer	46	113030081	4-Wege-Ventil zum Austauscher
14	108110004	Säule	47	116000066	Hochdruckschalter
15	112000031	Lüftermotor	48	113060123	Rohr
16	1330900261	Linke Seitenverkleidung	49	121000006	4-Wege-Ventil
17	132000015	Ventilatorflügel	50	150000110	Abflusstopfen
18	1330900251	Frontblende	51	117110012	Wasser in Temp. Sensor T1-TH6
19	108010014	Kühlergrill	52	108010025	Tauscher-Temperatursensor-Clip
20	117230003	Reaktor	53	102040705	Titan-Wärmetauscher
21	101000187	Dämpfungsfüße des Kompressors	54	133020026	Gummiring am Wasseranschluss
22	142000072	Kompressor Heizband	55	133020011	Blauer Gummiring
23	101000187	Kompressor	56	113900082	Wasseranschluss-Sets
24	113100008	Kupplungswerkzeug	57	133020011	Roter Gummiring
25	120000091	Durchgangsventil	58	117110011	Wasser austemp. Sensor T2-TH5
26	180140064	Basisfach	59	116000001	Siegelring
27	108010065	Klemmleiste	60	112100021-1	Wasserflussschalter
28	115000004	5-sitziges Terminal	61	117010095	Modbus-Modul
29	113100009	Clip	62	117240002	Magnetring
30	1330900281	Rechtes Panel	63	108110057	Elektrische Box
31	1332500051	Klemmenblock Kunststoffabdeckung	64	117240003	Magnetring
32	108010018	Anschlussdose	65	117100046	PCB
33	113712007	Wasserdichte Kontrollbox	66	108050017	Elektrische Boxabdeckung

9.3 Modell: 71677/71678/71679

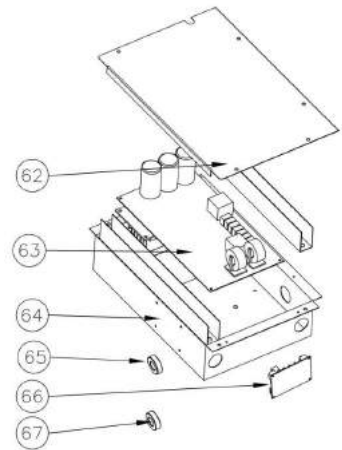
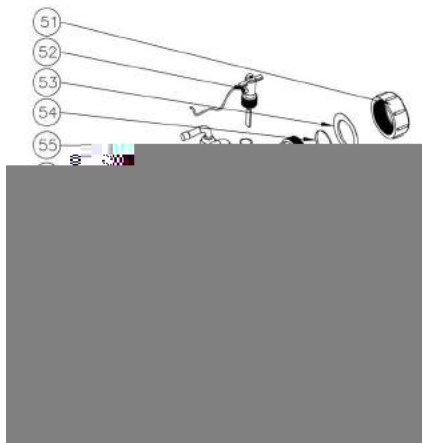
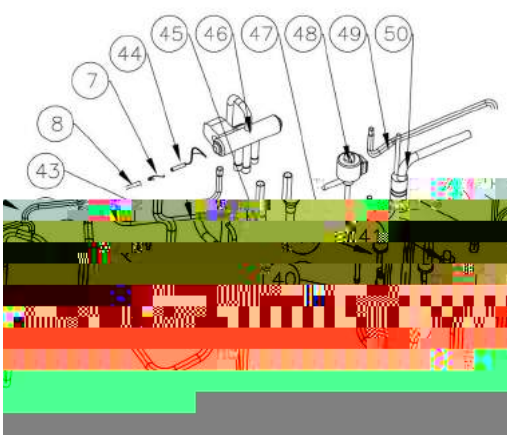
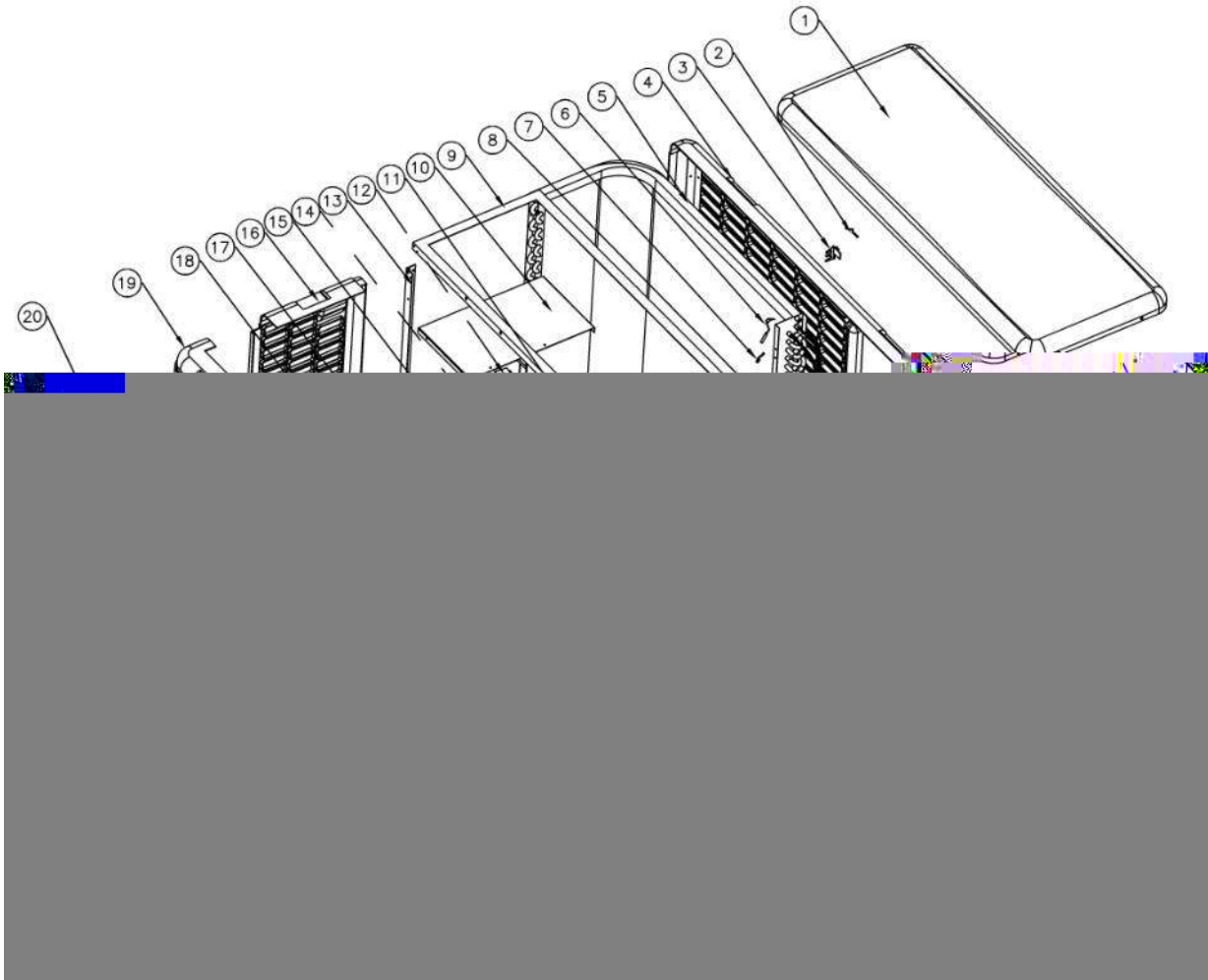

9.4 Ersatzteilliste: 71677

NO	ERP	Teile Name	NO	ERP	Teile Name
1	1330900291	Obere Abdeckung	35	113712007	Wasserdichte Controller-Box
2	117110020	Umgebungstemp. Sensor T5-TH1	36	117020180	Regler
3	133020010	Umgebungstemp. Sensorklemme	37	103000221	Kollektive Verrohrung
4	1330900271	Rückwand	38	136020005	Gummiblock
5	103000221	Verdampfer	39	103000221	Verteilungsrohrleitung
6	117110004	Rohrtemp. Sensor T3-TH2	40	113030086	4-Wege-Ventil zum Austauscher
7	113100009	Clip	41	116000066	Hochdruckschalter
8	113100009	Sensorgehäuserohr	42	116000071	Niederdruckschalter
9	108110038	Oberrahmen	43	113010210	Auspuff
10	108110043	Lüftermotorhalterung	44	117110021	Abgastemperatur Sensor T6-TH3
11	117230003	Reaktor	45	113020322	Gasrückführleitung
12	108480015	Gürtelklemme	46	121000006	4-Wege-Ventil
13	108110004	Säule	47	113060084	4-Wege-Ventil zur Sammelleitung
14	142000079	Heizband Verdampfer	48	119000017	EEV
15	112000031	Lüftermotor	49	113080054	EEV zu Verteilerleitungen
16	1330900261	Linke Seitenwand	50	113070044	Austauscher zu EEV
17	108010024	DC-Motorrohrabdeckung	51	113900082	Wasseranschluss-Sets
18	132000015	Ventilatorflügel	52	112100021-1	Wasserstromschalter
19	1330900251	Frontblende	53	133020012	Roter Gummiring
20	108010014	Kühlergrill	54	133020026	Gummiring am Wasseranschluss
21	108050073	Isolierplatte	55	136020083	Siegelring
22	113100008	Kupferrohr	56	117110011	Wasser aus Temp. Sensor T2-TH5
23	120000091	Durchgangsventil	57	108010025	Temperatursensor-Clip des Wärmetauschers
24	142000074	Kompressor-Heizband	58	102040748	Titan-Wärmetauscher
25	101000188	Kompressor Dämpfungsfüße	59	133020011	Blauer Gummiring
26	101000188	Kompressor	60	117110012	Wasser in Temp. Sensor T1-TH6
27	108110066	Bodenwanne	61	150000110	Ablassschraube
28	108010065	Klemmenleiste	62	108050017	Elektrischer Kastendeckel
29	133090028	Rechter Bereich	63	117100046	Leiterplatte
30	106000011	Druckanzeige	64	108110031	Elektrische Box
31	136010004	Clip	65	117240002	Magnetring
32	115000004	5-Sitzer-Terminal	66	117010095	Modbus-Modul
33	1332500051	Klemmenblöcke Kunststoffabdeckung	67	117240003	Magnetring
34	133030011	Anschlussdose			

9.5 Ersatzteilliste: 71678

NO	ERP	Teile Name	NO	ERP	Teile Name
1	1330900291	Obere Abdeckung	35	113712007	Wasserdichte Kontrollbox
2	117110020	Umgebungstemp. Sensor T5-TH1	36	117020180	Regler
3	133020010	Umgebungstemp. Sensorclip	37	103000182	Kollektive Rohrleitungen
4	1330900271	Rückseite	38	136020005	B-Form Gummi
5	103000182	Verdampfer	39	103000182	Piping Verteilung
6	117110004	Rohrtemp. Sensor T3-TH2	40	113030086	4-Wege-Ventil zum Austauscher
7	113100009	Sensorgehäuseleitung	41	116000066	Hochdruckschalter
8	113100009	Klammer	42	116000071	Niederdruckschalter
9	108110038	Oberer Rahmen	43	113010210	Auspuffrohr
10	108110043	Lüftermotorhalterung	44	117110021	Abgastemp. Sensor T6-TH3
11	117230003	Reaktor	45	113020322	Gasrückführung
12	108480015	Gürtel fix	46	121000006	4-Wege-Ventil
13	108110004	Säule	47	113060084	4-Wege-Ventil zu Sammelrohrleitungen
14	142000079	Heizband Verdampfer	48	119000017	EEV
15	112000031	Lüftermotor	49	113080054	EEV zu Verteilungsrohrleitungen
16	1330900261	Linke Seitenverkleidung	50	113070044	Austauscher zu EEV
17	108010024	DC-Motorrohrabdeckung	51	113900082	Wasseranschluss-Sets
18	132000015	Lüfterklinge	52	112100021-1	Wasserflussschalter
19	133090025	Frontplatte	53	133020011	Roter Gummiring
20	108010014	Frontgrill	54	133020026	Gummiring am Wasseranschluss
21	108050073	Isolationsplatte	55	116000001	Dichtring
22	113100008	Kupplungswerkzeug	56	117110011	Wasser austemp. Sensor T2-TH5
23	120000091	Absperrventil	57	117110012	Tauscher-Temperatursensor-Clip
24	142000074	Kompressor Heizband	58	102040708	Titan-Wärmetauscher
25	101000188	Dämpfungsfüße des Kompressors	59	133020011	Blauer Gummiring
26	101000188	Kompressor	60	117110012	Wasser in Temp. Sensor T1-TH6
27	108110066	Basisfach	61	150000110	Abflusstopfen
28	108010065	Klemmleiste	62	108050017	Elektrische Boxabdeckung
29	1330900281	Rechtes Panel	63	117100047	PCB
30	106000011	Manometer	64	108110057	Elektrischer Kasten
31	136010004	Klammer	65	117240002	Magnetring
32	115000004	5-sitziges Terminal	66	117010095	Modbus-Modul
33	1332500051	Klemmenblock Kunststoffabdeckung	67	117240003	Magnetring
34	133030011	Anschlussdose			

9.6 Ersatzteilliste: 71679

NO	ERP	Teile Name	NO	ERP	Teile Name
1	1330900291	Obere Abdeckung	35	113712007	Wasserdichte Kontrollbox
2	117110020	Umgebungstemp. Sensor T5-TH1	36	117020180	Controller
3	133020010	Umgebungstemp. Sensorclip	37	103000220	Kollektive Rohrleitungen
4	1330900271	Rückseite	38	136020005	B Formgummi
5	103000220	Verdampfer	39	103000220	Verteilungsrohrleitung
6	117110004	Rohrtemp. Sensor T3-TH2	40	113030081	4-Wege-Ventil zum Austauscher
7	113100009	Sensorgehäuseleitung	41	116000066	Hochdruckschalter
8		Clip	42	116000071	Niederdruckschalter
9	108110038	Oberer Rahmen	43	113010159	Auspuffrohr
10	108110043	Lüftermotorhalterung	44	117110021	Abgastemp. Sensor T6-TH3
11	117230003	Reaktor	45	113020321	Gasrückführung
12	108480015	Heizbandklammer Verdampfer	46	121000006	4-Wege-Ventil
13	108110004	Säule	47	113060084	4-Wege-Ventil zu Sammelrohrleitungen
14	142000079	Heizband Verdampfer	48	119000017	EEV
15	112000031	Lüftermotor	49	113080054	EEV zu Verteilungsrohrleitungen
16	1330900261	Linke Seitenverkleidung	50	113070041	Austauscher zu EEV
17	108010024	DC-Motorabdeckung	51	113900082	Wasseranschluss-Sets
18	132000015	Lüfterklinge	52	112100021-1	Wasserflussschalter
19	1330900251	Frontplatte	53	133020012	Roter Gummiring
20	108010014	Frontgrill	54	133020026	Gummiringam Wasseranschluss
21	108050073	Isolationsplatte	55	116000001	Dichtring
22	113100008	Rohrleitungen	56	117110011	Wasser austemp. Sensor T2-TH5
23	120000091	Absperrventil	57	108010025	Tauscher-Temperatursensor-Clip
24	142000074	Kompressor Heizband	58	102040710	Titan-Wärmetauscher
25	101000181	Kompressor Gummifüße	59	133020011	Blauer Gummiring
26	101000181	Kompressor	60	117110012	Wasser in Temp. Sensor T1-TH6
27	108110044	Basisfach	61	150000110	Abflusstopfen
28	108010065	Klemmleiste	62	108050017	Elektrische Boxabdeckung
29	133090028	Rechtes Panel	63	117100047	PCB
30	106000011	Manometer	64	108110045	Elektrischer Kasten
31	136010004	Clip	65	117240002	Magnetring
32	115000004	5-sitziges Terminal	66	117010095	Modbus-Module
33	1332500051	Klemmenblock Kunststoffabdeckung	67	117240003	Magnetring
34	133030011	Verdrahtungsbox			

9.8 Ersatzteilliste: 71680

NO	ERP	Teile Name	NO	ERP	Teile Name
1	1332600011	Obere Abdeckung	37	1332600041	Rechter Bereich
2	1332600021	Rückwand	38	103000230	Verteilungsrohrleitung
3	117110020	Umgebungstemp. Sensor T5-TH1	39	136020005	Gummiblock
4	133020010	Umgebungstemp. Sensorklemme	40	103000230	Kollektive Verrohrung
5	103000230	Verdampfer	41	113020338	Gasrückführleitung
6	113100009	Sensorgehäuserohr	42	116000073	Niederdruckschalter
7	113100009	Clip	43	113130021	Filter zu Flüssigkeitsspeicher
8	117110004	Rohrtemp. Sensor T3-TH2	44	120000066	Filter
9	117230002	Reaktor	45	113060122	4-Wege-Ventil zur Sammelleitung
10	108560003	Säule	46	116000068	Hochdruckschalter
11	108560002	Oberrahmen	47	113010244	Auspuff
12	108480015	Gürtelklemme	48	117110021	Abgastemperatur Sensor T6-TH3
13	142000079	Heizband Verdampfer	49	121000006	4-Wege-Ventil
14	108560011	Lüftermotorhalterung	50	113170032	Austauscher zum Filter
15	112000031	Lüftermotor	51	113120019	Flüssigkeitsvorratsbehälter zu EEV
16	132000023	Ventilatorflügel	52	113030108	4-Wege-Ventil zum Austauscher
17	1332600051	Linke Seitenwand	53	119000021	EEV
18	1332600031	Frontblende	54	113080056	EEV zu Verteilerleitungen
19	108170017	Kühlergrill	55	150000110	Ablassschraube
20	108560036	Bodenwanne	56	108010025	Temperatursensor-Clip des Wärmetauschers
21	101000185	Kompressor	57	117110012	Wasser in Temp. Sensor T1-TH6
22	101000185	Kompressor Dämpfungsfüße	58	133020026	Gummiring am Wasseranschluss
23	142000077	Kompressor-Heizband	59	133020011	Blauer Gummiring
24	105000004	Flüssigkeitsvorratsbehälter	60	102040703	Titan-Wärmetauscher
25	108560010	Isolierplatte	61	113900082	Wasseranschluss-Sets
26	120000091	Durchgangsventil	62	117110011	Wasser aus Temp. Sensor T2-TH5
27	108560034	Kugelventil Bord	63	136020083	Siegelring
28	113100008	Kupferrohr	64	112100021-1	Wasserstromschalter
29	108010065	Klemmenleiste	65	133020012	Roter Gummiring
30	133030011	Anschlussdose	66	117010095	Modbus-Modul
31	136010004	Clip	67	117240002	Magnetring
32	106000011	Druckanzeige	68	117240003	Magnetring
33	1332500051	Klemmenblöcke Kunststoffabdeckung	69	108560012	Elektrische Box
34	115000004	5-Sitzer-Terminal	70	117100048	Leiterplatte
35	117020180	Regler	71	108540006	Elektrischer Kastendeckel
36	113712007	Wasserdichte Controller-Box			

9.9 Ersatzteilliste: 71681

NO	ERP	Teile Name	NO	ERP	Teile Name
1	1332600011	Obere Abdeckung	37	1332600041	Rechter Bereich
2	1332600021	Rückwand	38	103000204	Verteilungsrohrleitung
3	117110020	Umgebungstemp. Sensor T5-TH1	39	136020005	Gummiblock
4	133020010	Umgebungstemp. Sensorklemme	40	103000204	Kollektive Verrohrung
5	103000204	Verdampfer	41	113020339	Gasrückführleitung
6	113100009	Sensorgehäuserohr	42	116000073	Niederdruckschalter
7	113100009	Clip	43	113130021	Filter zu Flüssigkeitsspeicher
8	117110004	Rohrtemp. Sensor T3-TH2	44	120000066	Filter
9	117230002	Reaktor	45	113060096	4-Wege-Ventil zur Sammelleitung
10	108560003	Säule	46	116000068	Hochdruckschalter
11	108560002	Oberrahmen	47	113010245	Auspuff
12	108480015	Gürtelklemme	48	117110021	Abgastemperatur Sensor T6-TH3
13	142000144	Heizband Verdampfer	49	121000009	4-Wege-Ventil
14	108560011	Lüftermotorhalterung	50	113170032	Austauscher zum Filter
15	112000031	Lüftermotor	51	113120019	Flüssigkeitsvorratsbehälter zu EEV
16	132000023	Ventilatorflügel	52	113030093	4-Wege-Ventil zum Austauscher
17	1332600051	Linke Seitenwand	53	119000021	EEV
18	1332600031	Frontblende	54	113080056	EEV zu Verteilerleitungen
19	108170017	Kühlergrill	55	150000110	Ablassschraube
20	108560036	Bodenwanne	56	108010025	Temperatursensor-Clip des Wärmetauschers
21	101000185	Kompressor	57	117110012	Wasser in Temp. Sensor T1-TH6
22	101000185	Kompressor Dämpfungsfüße	58	133020026	Gummiring am Wasseranschluss
23	142000077	Kompressor-Heizband	59	133020011	Blauer Gummiring
24	105000004	Flüssigkeitsvorratsbehälter	60	102040764	Titan-Wärmetauscher
25	108560010	Isolierplatte	61	113900082	Wasseranschluss-Sets
26	120000091	Durchgangsventil	62	117110011	Wasser aus Temp. Sensor T2-TH5
27	108560034	Kugelventil Bord	63	136020083	Siegelring
28	113100008	Kupferrohr	64	112100021-1	Wasserstromschalter
29	108010065	Klemmenleiste	65	133020012	Roter Gummiring
30	133030011	Anschlussdose	66	117010095	Modbus-Modul
31	136010004	Clip	67	117240002	Magnetring
32	106000011	Druckanzeige	68	117240003	Magnetring
33	1332500051	Klemmenblöcke Kunststoffabdeckung	69	108560012	Elektrische Box
34	115000004	5-Sitzer-Terminal	70	117100048	Leiterplatte
35	117020180	Regler	71	108540006	Elektrischer Kastendeckel
36	113712007	Wasserdichte Controller-Box			

9.10 Modell: 71682,71683

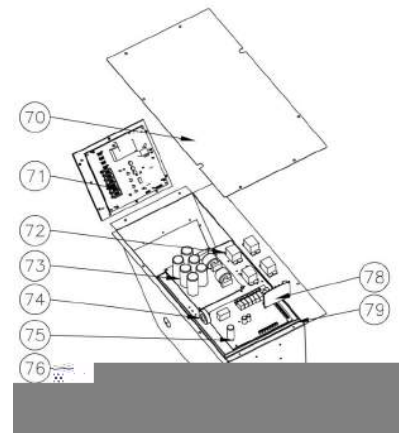
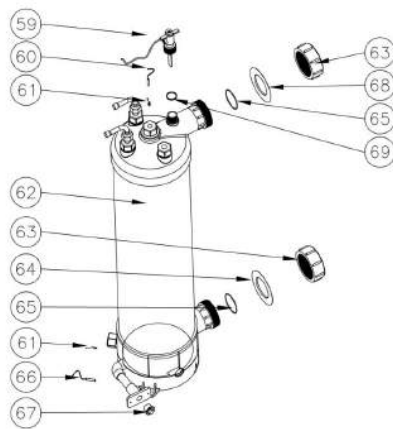
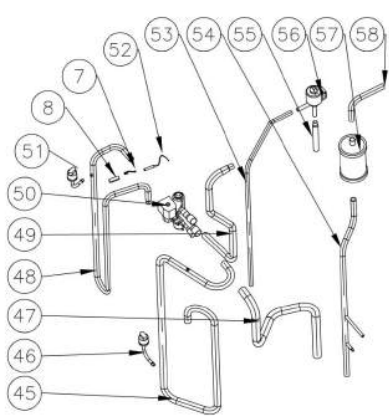
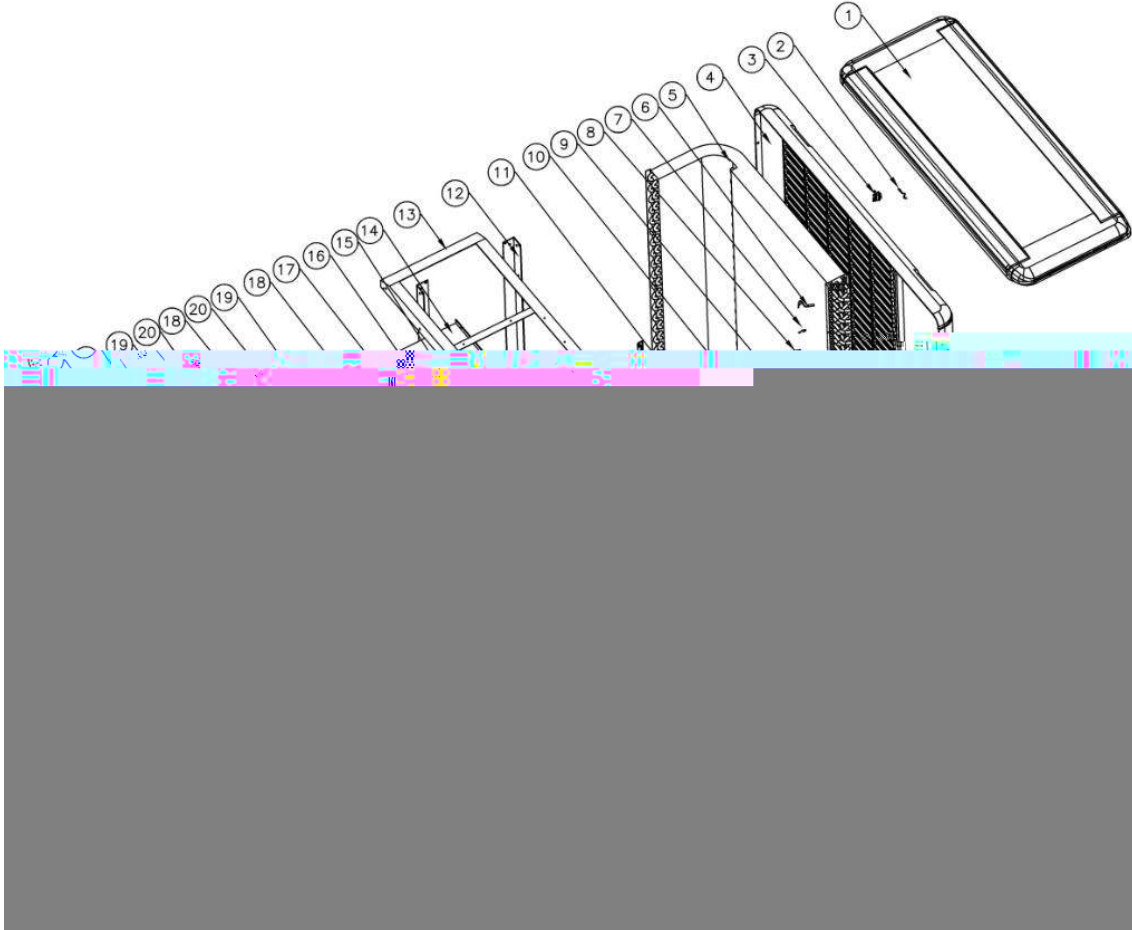

9.11 Ersatzteilliste: 71682

NO	ERP	Teile Name	NO	ERP	Teile Name
1	133100001	Obere Abdeckung	41	117020180	Regler
2	117110020	Umgebungstemperatur. Sensor T5-TH1	42	113712007	Wasserdichte Controller-Box
3	133020010	Umgebungstemperatur. Sensorklemme	43	103000208	Kollektive Verrohrung
4	133250003	Rückwand	44	136020005	Gummiblock
5	103000208	Verdampfer	45	113020326	Gasrückführleitung
6	117110004	Rohrtemp. Sensor T3-TH2	46	116000073	Niederdruckschalter
7	113100009	Clip	47	113060083	4-Wege-Ventil zur Sammelleitung
8	113100009	Sensorgehäuserohr	48	113010227	Auspuff
9	103000208	Verteilungsrohrleitung	49	113030087	4-Wege-Ventil zum Austauscher
10	108120036	Isolierplatte	50	121000009	4-Wege-Ventil
11	117230001	Reaktor	51	116000008	Hochdruckschalter
12	108120035	Säule	52	117110021	Abgastemperatur Sensor T6-TH3
13	108120034	Oberrahmen	53	113120020	Flüssigkeitsvorratsbehälter zu EEV
14	108120044	Lüftermotorhalterung	54	113130020	Filter zu Flüssigkeitsspeicher
15	108480015	Gürtelklemme	55	113080055	EEV zu Verteilerleitungen
16	142000079	Heizband Verdampfer	56	119000021	EEV
17	108550009	Säule	57	120000066	Filter
18	112000031	Lüftermotor	58	113170028	Austauscher zum Filter
19	132000015	Ventilatorflügel	59	112100021-1	Wasserstromschalter
20	108010024	DC-Motorrohrabdeckung	60	117110011	Wasser aus Temp. Sensor T2-TH5
21	133250004	Linke Seitenwand	61	108010025	Temperatursensor-Clip des Wärmetauschers
22	133250001	Frontblende	62	102040749	Titan-Wärmetauscher
23	108010014	Kühlergrill	63	113900082	Wasseranschluss-Sets
24	120000091	Durchgangsventil	64	133020012	Blauer Gummiring
25	113100008	Kupferrohr	65	133020026	Gummiring am Wasseranschluss
26	101000185	Kompressor	66	117110012	Wasser in Temp. Sensor T1-TH6
27	101000185	Kompressor Dämpfungsfüße	67	150000110	Ablassschraube
28	105000008	Flüssigkeitsvorratsbehälter	68	133020011	Roter Gummiring
29	142000077	Kompressor-Heizband	69	136020083	Siegelring
30	108550005	Bodenwanne	70	108120040	Elektrischer Kastendeckel
31	108550008	Griffsäule	71	117140016	Treiberplatine
32	108010065	Klemmenleiste	72	142000038	Relais
33	133250002	Rechter Bereich	73	117260001	Filterplatine
34	115000025	3-Sitzer Terminal für Strom	74	117240002	Magnetring
35	106000011	Druckanzeige	75	117250007	Leiterplatte
36	136010004	Clip	76	108120038	Elektrische Box
37	108550006	Säule	77	117240003	Magnetring
38	115000027	3-sitziges Terminal für Wasserpumpe	78	117010095	Modbus-Modul
39	133250005	Klemmenblöcke Kunststoffabdeckung	79	108120039	Brett skalieren
40	133030011	Anschlussdose			

9.12 Ersatzteilliste: 71683

NO	ERP	Teile Name	NO	ERP	Teile Name
1	133100001	Obere Abdeckung	41	117020180	Regler
2	117110020	Umgebungstemperatur. Sensor T5-TH1	42	113712007	Wasserdichte Controller-Box
3	133020010	Umgebungstemperatur. Sensorklemme	43	103000209	Kollektive Verrohrung
4	133250003	Rückwand	44	136020005	Gummiblock
5	103000209	Verdampfer	45	113020389	Gasrückführleitung
6	117110004	Rohrtemp. Sensor T3-TH2	46	116000073	Niederdruckschalter
7	113100009	Clip	47	113060083	4-Wege-Ventil zur Sammelleitung
8	113100009	Sensorgehäuserohr	48	113010228	Auspuff
9	103000209	Verteilungsrohrleitung	49	113030087	4-Wege-Ventil zum Austauscher
10	108120036	Isolierplatte	50	121000009	4-Wege-Ventil
11	117230001	Reaktor	51	116000008	Hochdruckschalter
12	108120035	Säule	52	117110021	Abgastemperatur Sensor T6-TH3
13	108120034	Oberrahmen	53	113120020	Flüssigkeitsvorratsbehälter zu EEV
14	108120044	Lüftermotorhalterung	54	113130020	Filter zu Flüssigkeitsspeicher
15	108480015	Gürtelklemme	55	113080055	EEV zu Verteilerleitungen
16	142000079	Heizband Verdampfer	56	119000042	EEV
17	108550009	Säule	57	120000066	Filter
18	112000031	Lüftermotor	58	113170028	Austauscher zum Filter
19	132000015	Ventilatorflügel	59	112100021-1	Wasserstromschalter
20	108010024	DC-Motorrohrabdeckung	60	117110011	Wasser aus Temp. Sensor T2-TH5
21	133250004	Linke Seitenwand	61	108010025	Temperatursensor-Clip des Wärmetauschers
22	133250001	Frontblende	62	102040754	Titan-Wärmetauscher
23	108010014	Kühlergrill	63	113900082	Wasseranschluss-Sets
24	120000091	Durchgangsventil	64	133020012	Blauer Gummiring
25	113100008	Kupferrohr	65	133020026	Gummiring am Wasseranschluss
26	101000186	Kompressor	66	117110012	Wasser in Temp. Sensor T1-TH6
27	101000186	Kompressor Dämpfungsfüße	67	150000110	Ablassschraube
28	105000008	Flüssigkeitsvorratsbehälter	68	133020011	Roter Gummiring
29	142000077	Kompressor-Heizband	69	136020083	Siegelring
30	108470069	Bodenwanne	70	108120040	Elektrischer Kastendeckel
31	108550008	Griffsäule	71	117140016	Treiberplatine
32	108010065	Klemmenleiste	72	142000038	Relais
33	133250002	Rechter Bereich	73	117260001	Filterplatine
34	115000025	3-Sitzer Terminal für Strom	74	117240002	Magnetring
35	106000011	Druckanzeige	75	117250007	Leiterplatte
36	136010004	Clip	76	108120038	Elektrische Box
37	108550006	Säule	77	117240003	Magnetring
38	115000027	3-sitziges Terminal für Wasserpumpe	78	117010095	Modbus-Modul
39	133250005	Klemmenblöcke Kunststoffabdeckung	79	108120039	Brett skalieren
40	133030011	Anschlussdose			

9.13 Modell: 68821/68822/68823

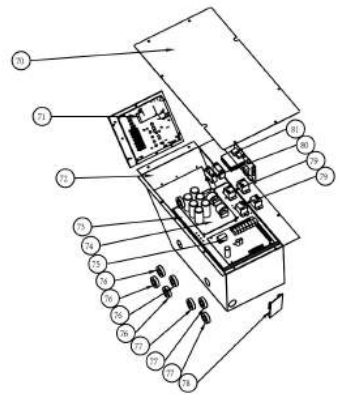
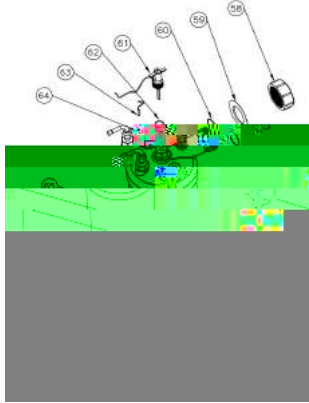
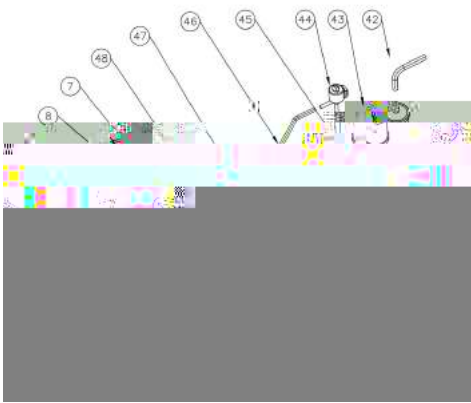
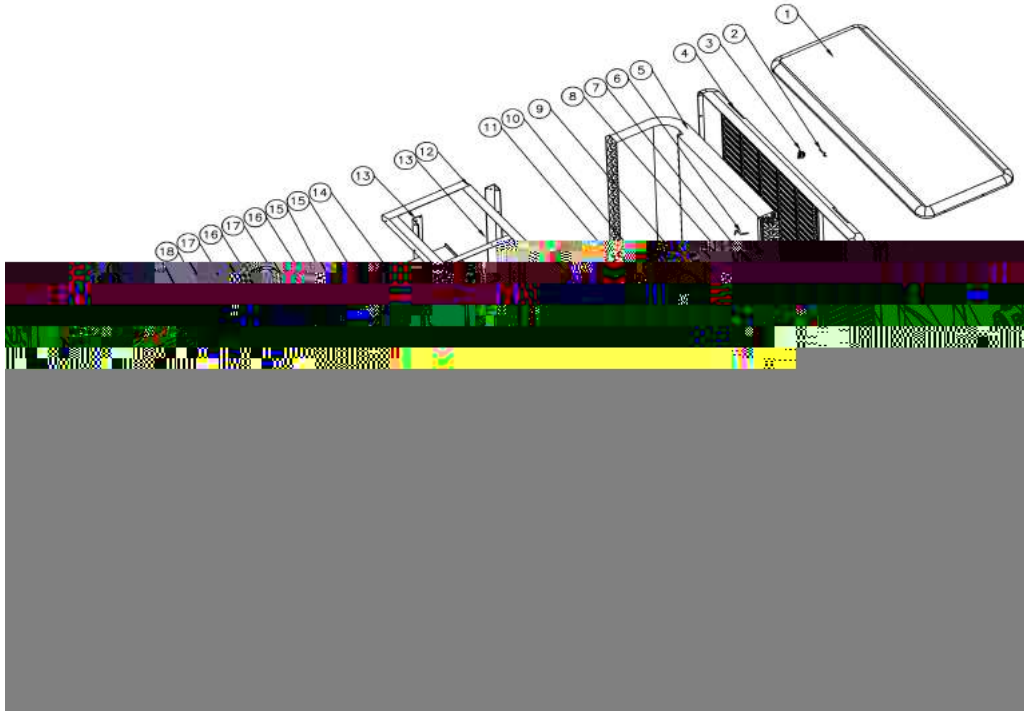

9.14 Ersatzteilliste: 68821

NO	ERP	Teilname	NO	ERP	Teilname
1	133100001	Obere Abdeckung	41	113050109	Kollektive Verrohrung
2	117110020	Umgebungstemperatur. Sensor T5-TH1	42	113170028	Austauscher zum Filter
3	133020010	Umgebungstemperatur. Sensorklemme	43	120000066	Filter
4	133250003	Rückwand	44	119000022	EEV
5	103000153	Verdampfer	45	113080055	EEV zu Verteilerleitungen
6	117110004	Rohrtemp. Sensor T3-TH2	46	113120020	Flüssigkeitsvorratsbehälter zu EEV
7	113190001	Clip	47	113030087	4-Wege-Ventil zum Austauscher
8	113190001	Sensorgehäuserohr	48	117110021	Abgastemperatur Sensor T6-TH3
9	113040101	Verteilungsrohrleitung	49	116000008	Hochdruckschalter
10	108550010	Isolierplatte	50	121000009	4-Wege-Ventil
11	117230002	Reaktor	51	120000023	Saugventil
12	108120034	Oberrahmen	52	113010158	Auspuff
13	108120035	Säule	53	116000080	Niederdruckschalter 0.2-0.35
14	108120037	Lüftermotorhalterung	54	116000079	Niederdruckschalter 0.1-0.3
15	112000031	Lüftermotor	55	113020245	Gasrückführleitung
16	108010024	Lüftermotor-Rohrabdeckung	56	113060083	4-Wege-Ventil zur Sammelleitung
17	132000015	Ventilatorflügel	57	113130015	Filter zu Flüssigkeitsspeicher
18	133250004	Linke Seitenwand	58	113900082	Wasseranschluss-Sets
19	133250001	Frontblende	59	133020011	Roter Gummiring
20	108010014	Kühlergrill	60	133020026	Gummiring am Wasseranschluss
21	108550009	Säule	61	112100021-1	Wasserstromschalter
22	108550005	Bodenwanne	62	116000001-2	Siegelring
23	101000149	Kompressor	63	117110011	Wasser aus Temp. Sensor T2-TH5
24	105000008	Flüssigkeitsvorratsbehälter	64	108010025	Temperatursensor-Clip des Wärmetauschers
25	142000077	Kompressor-Heizband	65	113900082	Wasseranschluss-Sets
26	101000149	Kompressor Dämpfungsfüße	66	133020012	Blauer Gummiring
27	108550008	Griffsäule	67	102040503	Titan-Wärmetauscher
28	108010065	Klemmenleiste	68	117110012	Wasser in Temp. Sensor T1-TH6
29	110000008	Drahtverbindung	69	150000110	Ablassschraube
30	108010018	Anschlusskasten	70	108120040	Elektrischer Kastendeckel
31	133250002	Rechter Bereich	71	117140003	Treiberplatine
32	115000025	3-Platz Terminal für Strom	72	108120038	Elektrische Box
33	110800001	Druckanzeige	73	108120039	Skalierungsboard
34	136010004	Clip	74	117260002	Filterplatte
35	108550006	Säule	75	117250001-V	Leiterplatte
36	115000027	3-Platz Terminal für Wasserpumpe	76	117240002	Magnetring
37	133250005	Klemmenblöcke Kunststoffabdeckung	77	117240003	Magnetring
38	113712007	Wasserdichte Controller-Box	78	117010095	Modbus-Modul
39	117020150	Regler	79	142000038	Relais
40	136020005	Gummiblock	80	N/A	N/A
			81	117140006	Lüfter-Motor-Treiberplatine

9.15 Ersatzteilliste: 68822

NO	ERP	Teilename	NO	ERP	Teilename
1	133100001	Obere Abdeckung	41	113050110	Kollektive Verrohrung
2	117110020	Umgebungstemperatur. Sensor T5-TH1	42	113170028	Austauscher zum Filter
3	133020010	Umgebungstemperatur. Sensorklemme	43	120000066	Filter
4	133250003	Rückwand	44	119000022	EEV
5	103000154	Verdampfer	45	113080055	EEV zu Verteilerleitungen
6	117110004	Rohrtemp. Sensor T3-TH2	46	113120020	Flüssigkeitsvorratsbehälter zu EEV
7	113190001	Clip	47	113030087	4-Wege-Ventil zum Austauscher
8	113190001	Sensorgehäuserohr	48	117110021	Abgastemperatur Sensor T6-TH3
9	113040102	Verteilungsrohrleitung	49	116000008	Hochdruckschalter
10	108550010	Isolierplatte	50	121000009	4-Wege-Ventil
11	117230004	Reaktor	51	120000023	Saugventil
12	108120034	Oberrahmen	52	113010158	Auspuff
13	108120035	Säule	53	116000080	Niederdruckschalter 0.2-0.35
14	108120037	Lüftermotorhalterung	54	116000079	Niederdruckschalter 0.1-0.3
15	112000031	Lüftermotor	55	113020245	Gasrückführleitung
16	108010024	Lüftermotor-Rohrabdeckung	56	113060083	4-Wege-Ventil zur Sammelleitung
17	132000015	Ventilatorflügel	57	113130015	Filter zu Flüssigkeitsspeicher
18	133250004	Linke Seitenwand	58	113900082	Wasseranschluss-Sets
19	133250001	Frontblende	59	133020011	Roter Gummiring
20	108010014	Kühlergrill	60	133020026	Gummiring am Wasseranschluss
21	108550009	Säule	61	112100021-1	Wasserstromschalter
22	108550005	Bodenwanne	62	116000001-2	Siegelring
23	101000122	Kompressor	63	117110011	Wasser aus Temp. Sensor T2-TH5
24	105000008	Flüssigkeitsvorratsbehälter	64	108010025	Temperatursensor-Clip des Wärmetauschers
25	142000077	Kompressor-Heizband	65	113900082	Wasseranschluss-Sets
26	101000122	Kompressor Dämpfungsfüße	66	133020012	Blauer Gummiring
27	108550008	Griffsäule	67	102040502	Titan-Wärmetauscher
28	108010065	Klemmenleiste	68	117110012	Wasser in Temp. Sensor T1-TH6
29	110000008	Drahtverbindung	69	150000110	Ablassschraube
30	108010018	Anschlusskasten	70	108120040	Elektrischer Kastendeckel
31	133250002	Rechter Bereich	71	117140002	Treiberplatine
32	115000025	3-Platz Terminal für Strom	72	108120038	Elektrische Box
33	110800001	Druckanzeige	73	108120039	Skalierungsboard
34	136010004	Clip	74	117260001	Filterplatte
35	108550006	Säule	75	117250001-V1.5	Leiterplatte
36	115000027	3-Platz Terminal für Wasserpumpe	76	117240002	Magnetring
37	133250005	Klemmenblöcke Kunststoffabdeckung	77	117240003	Magnetring
38	113712007	Wasserdichte Controller-Box	78	117010095	Modbus-Modul
39	117020150	Regler	79	142000038	Relais
40	136020005	Gummiblock	80	N/A	N/A
			81	N/A	N/A

9.16 Ersatzteilliste: 68823

NO	ERP	Teilename	NO	ERP	Teilename
1	133100001	Obere Abdeckung	41	113050110	Kollektive Verrohrung
2	117110020	Umgebungstemperatur. Sensor T5-TH1	42	113170028	Austauscher zum Filter
3	133020010	Umgebungstemperatur. Sensorklemme	43	120000066	Filter
4	133250003	Rückwand	44	119000022	EEV
5	103000154	Verdampfer	45	113080055	EEV zu Verteilerleitungen
6	117110004	Rohrtemp. Sensor T3-TH2	46	113120020	Flüssigkeitsvorratsbehälter zu EEV
7	113190001	Clip	47	113030087	4-Wege-Ventil zum Austauscher
8	113190001	Sensorgehäuserohr	48	117110021	Abgastemperatur Sensor T6-TH3
9	113040102	Verteilungsrohrleitung	49	116000008	Hochdruckschalter
10	108550010	Isolierplatte	50	121000009	4-Wege-Ventil
11	117230002	Reaktor	51	120000023	Saugventil
12	108120034	Oberrahmen	52	113010158	Auspuff
13	108120035	Säule	53	116000080	Niederdruckschalter 0.2-0.35
14	108120037	Lüftermotorhalterung	54	116000079	Niederdruckschalter 0.1-0.3
15	112000031	Lüftermotor	55	113020245	Gasrückführleitung
16	108010024	Lüftermotor-Rohrabdeckung	56	113060083	4-Wege-Ventil zur Sammelleitung
17	132000015	Ventilatorflügel	57	113130015	Filter zu Flüssigkeitsspeicher
18	133250004	Linke Seitenwand	58	113900082	Wasseranschluss-Sets
19	133250001	Frontblende	59	133020011	Roter Gummiring
20	108010014	Kühlergrill	60	133020026	Gummiring am Wasseranschluss
21	108550009	Säule	61	112100021-1	Wasserstromschalter
22	108550005	Bodenwanne	62	116000001-2	Siegelring
23	101000149	Kompressor	63	117110011	Wasser aus Temp. Sensor T2-TH5
24	105000008	Flüssigkeitsvorratsbehälter	64	108010025	Temperatursensor-Clip des Wärmetauschers
25	142000077	Kompressor-Heizband	65	113900082	Wasseranschluss-Sets
26	101000149	Kompressor Dämpfungsfüße	66	133020012	Blauer Gummiring
27	108550008	Griffsäule	67	102040502	Titan-Wärmetauscher
28	113712007	Klemmenleiste	68	117110012	Wasser in Temp. Sensor T1-TH6
29	110000008	Drahtverbindung	69	150000110	Ablassschraube
30	108010018	Anschlusskasten	70	108120040	Elektrischer Kastendeckel
31	133250002	Rechter Bereich	71	117140003	Treiberplatine
32	115000006	3-Platz Terminal für Strom	72	108120038	Elektrische Box
33	110800001	Druckanzeige	73	108120039	Skalierungsboard
34	136010004	Clip	74	117260002	Filterplatte
35	108550006	Säule	75	117250001-V1.5	Leiterplatte
36	115000027	3-Platz Terminal für Wasserpumpe	76	117240002	Magnetring
37	133250005	Klemmenblöcke Kunststoffabdeckung	77	117240003	Magnetring
38	113712007	Wasserdichte Controller-Box	78	117010095	Modbus-Modul
39	117020150	Regler	79	142000038	Relais
40	136020005	Gummiblock	80	N/A	N/A
			81	117140006	Lüfter-Motor-Treiberplatine

9.16 Wartung

- (1) Sie sollten das Wasserzufuhrsystem regelmäßig überprüfen, um zu vermeiden, dass Luft in das System eindringt und eine geringe Wasserflussmenge verursacht, denn das würde die Leistung und Zuverlässigkeit der HP-Einheit reduzieren.
- (2) Reinigen Sie ihr Becken und Filtersystem regelmäßig, um Schäden an der Einheit durch verschmutzte Filter zu vermeiden.
- (3) Sie sollten das Wasser am Boden der Wasserpumpe auslassen, wenn die HP-Einheit für längere Zeit unbenutzt bleiben soll (besonders im Winter).
- (4) Ansonsten sollten Sie überprüfen, ob die Einheit mit Wasser gefüllt ist, bevor Sie diese einschalten.
- (5) Nachdem die Einheit für die Wintersaison ausgerüstet wurde, sollte sie mit einer speziellen Winterdecke abgedeckt werden.
- (6) Während die Einheit läuft ist es normal wenn ein wenig Wasser darunter ausläuft.
- (7) Die Gasabfüllung muss von einem Fachmann mit R32-Betriebserlaubnis durchgeführt werden.
- (8) Bitte füllen Sie das R32-Gas aus dem Absperrventil in der Maschine ein.





POMPA DI CALORE PER PISCINE

PRO ELYO INVERBOOST NN

1. Descrizione
2. Informazioni per il trasporto
3. Specifiche
4. Kit di installazione
5. Posizionamento e collegamento
6. Cablaggio elettrico
7. Avvio della pompa di calore
8. Risoluzione dei problemi
9. Esploso e manutenzione

Grazie per aver scelto la pompa di calore per piscine PRO-ELYO INVERBOOST NN per riscaldare la vostra piscina. La pompa ne riscalderà l'acqua mantenendone costante la temperatura quando quella ambiente varia tra i -20 e i 50°C.



ATTENZIONE:

- Per quanto concerne funzionamento e manutenzione attenersi a quanto suggerito nel presente manuale.
- Utilizzare solamente pezzi di ricambio standard
- Far funzionare il prodotto ed eseguire gli interventi di manutenzione con la frequenza consigliata nel presente manuale.



ATTENZIONE:

Avviso importante:

- Tenere sempre la pompa in un luogo ben ventilato e lontano da ogni possibile causa di incendio.
- Non operare saldature sui tubi se vi è ancora del gas refrigerante all'interno dell'apparecchiatura. Si prega di non effettuare una ricarica di gas in luoghi angusti.
- Svuotare sempre l'acqua presente nella pompa di calore quando la medesima rimane ferma, ovvero in inverno o quando la temperatura ambiente scende sotto lo 0°C. Altrimenti, si corre il rischio di congelamento nello scambiatore in titanio con un conseguente annullamento della garanzia.
- Prima di caricare il gas R32 tramite la valvola di chiusura situata all'interno dell'apparecchiatura occorre creare il vuoto nella pompa di calore.
- Scollegare sempre l'alimentazione di energia elettrica prima di aprire l'involucro e accedere all'interno della pompa di calore dove è presente elettricità ad alto voltaggio.
- Conservare il controller in un luogo asciutto o chiudere la copertura isolante per proteggerli dall'umidità che potrebbe danneggiarlo.
- Qualsiasi intervento sulla pompa di calore deve essere eseguito da un professionista munito di licenza per la manipolazione di gas R32.

1.1 Con la vostra pompa di calore vengono forniti

- Collegamento acqua da 50 mm 2 pezzi
- Manuale d'uso e manutenzione
- Collegamento condensati
- Cavo di segnale da 10 metri
- Scatola impermeabile
- Copertura invernale
- Base anti-vibrazione 4 pezzi

1.2 Dimensioni

Modello: 71676

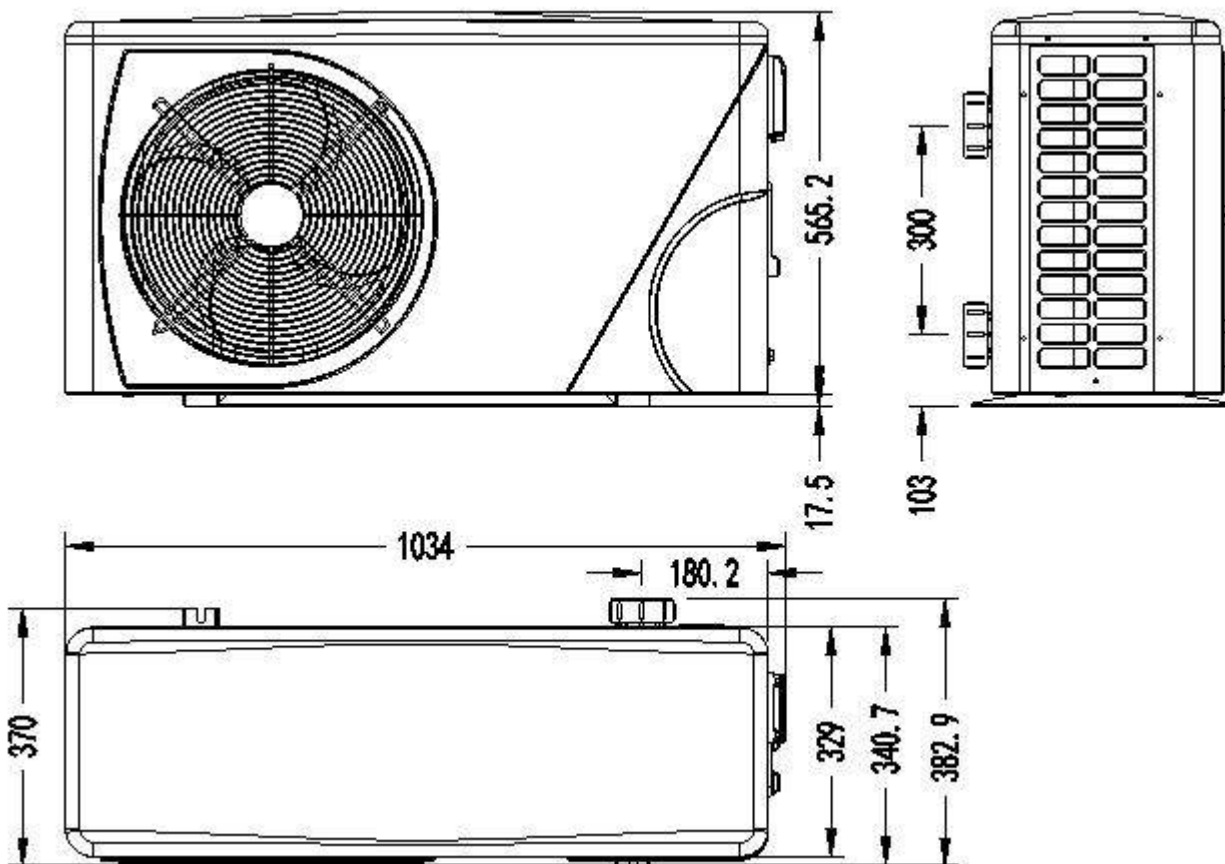

Modelli: 71677/71678/71679

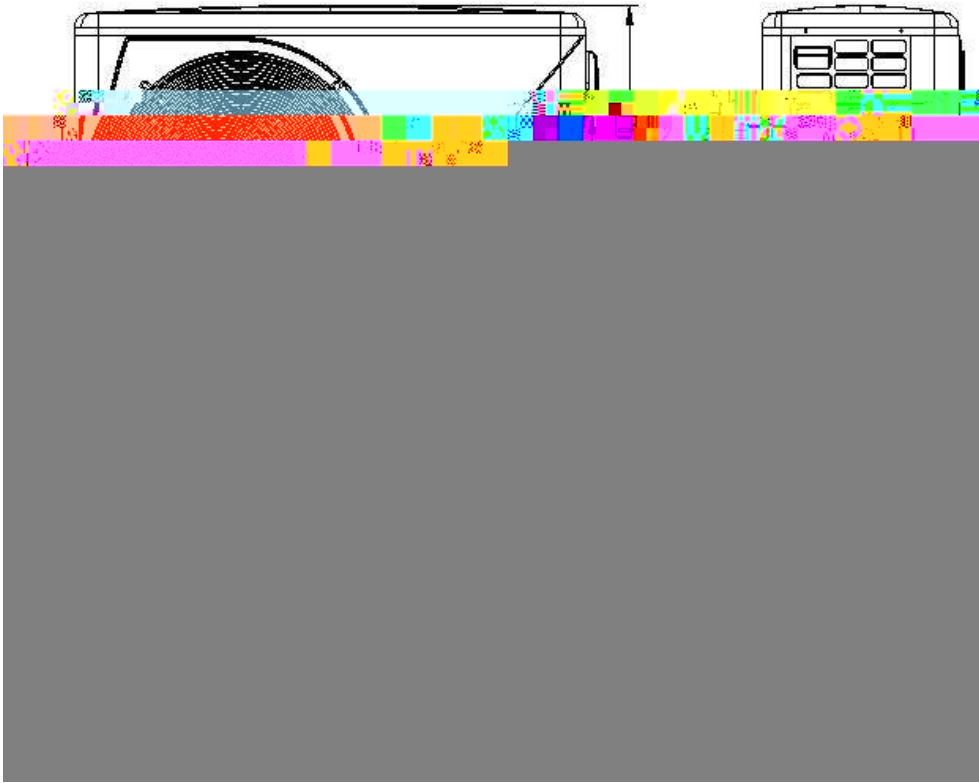

Modelli: 71680/71681

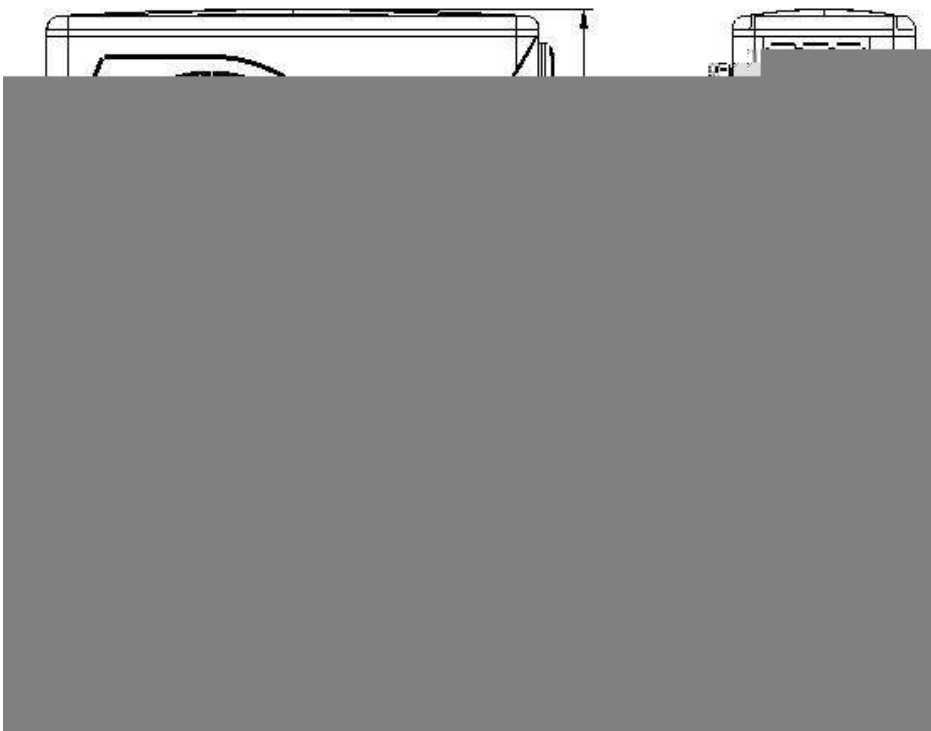

Modelli: 71682/71683/68821/68822/68823



2.1 Consegna del prodotto

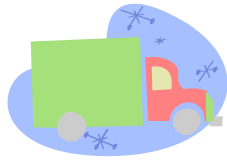

Dati tecnici relativi alle pompe di calore PRO ELYO INVERBOOST NN

Normativa CE, R32, Strutturato in ABS

MODELLO		PROELYXP07i	PROELYXP09i	PROELYXP11i	PROELYXP14i
CODICE		71676	71677	71678	71679
* Performance con Aria a 28°C, Acqua a 28°C, Umidità all'80%					
Capacità di riscaldamento	Kw	7-3.1	9-2.3	11-2.9	14-3.2
Consumo energetico	Kw	1.04-0.21	1.34-0.14	1.64-0.18	2.09-0.2
C.O.P.		15-6.7	16-6.7	16-6.7	16-6.7
* Performance con Aria a 15°C, Acqua a 26°C, Umidità al 70%					
Capacità di riscaldamento	Kw	4.7-2.5	6.6-1.9	7.9-2	10-2.3
Consumo energetico	Kw	0.94-0.32	1.32-0.24	1.58-0.25	1.9-0.29
C.O.P.		7.5-5	8.6-5	8.0-5	10-5
* Performance con Aria a 0°C, Acqua a 26°C, Umidità al 78%					
Capacità di riscaldamento	Kw	3.44-1.7	4.11-2.3	5.54-3.0	7.5-3.8
Consumo energetico	Kw	1.23-0.38	1.47-0.82	1.98-0.68	2.65-0.85
C.O.P.		4.5-2.8	4.4-2.8	4.4-2.8	5-2.8
* Performance con Aria a -10°C, Acqua a 26°C, Umidità al 78%					
Capacità di riscaldamento	Kw	2.41-1.5	3.13-2.0	3.87-2.7	5.1-3.15
Consumo energetico	Kw	1.21-0.35	1.42-0.53	1.76-0.69	2.32-0.81
C.O.P.		4.3-2	3.8-2.2	3.9-2.2	3.9-2.2
* Dati general					

Dati tecnici per pompe di calore per piscine PRO ELYO INVERBOOST NN

Normativa CE, R32, Struttura in ABS

MODELLO		PROELYXP16i	PROELYXP20i	PROELYXP26i	PROELYXP30i
CODICE		71680	71681	71682	71683
* Performance con Aria a 28°C, Acqua a 28°C, Umidità all'80%					
Capacità di riscaldamento	Kw	16-3.8	20-4.7	26-5.9	30-6.8
Consumo energetico	Kw	2.39-0.24	2.99-0.29	3.88-0.37	4.55-0.43
C.O.P.		16-6.7	16-6.7	16-6.7	16-6.6
* Performance con Aria a 15°C, Acqua a 26°C, Umidità al 70%					
Capacità di riscaldamento	Kw	11.2-3	14-3.9	18-5.4	22.8-5.6
Consumo energetico	Kw	2.24-0.38	2.8-0.49	3.6-0.68	4.56-0.68
C.O.P.		8.2-5	8.2-5	8.2-5	8.2-5
* Performance con Aria a 0°C, Acqua a 26°C, Umidità al 78%					
Capacità di riscaldamento	Kw	7.4-4.1	9.79-4.8	13-6.7	15.89-8.5
Consumo energetico	Kw	2.64-0.91	3.5-1.09	4.64-1.52	5.68-1.93
C.O.P.		4.5-2.8	4.4-2.8	4.4-2.8	4.4-2.8
* Performance con Aria a -10°C, Acqua a 26°C, Umidità al 78%					
Capacità di riscaldamento	Kw	5.8-3.6	7.58-4.3	10.4-5.9	12.74-7.4
Consumo energetico	Kw	2.64-0.92	3.45-1.1	4.73-1.51	5.79-1.95
C.O.P.		3.9-2.2	3.9-2.2	3.9-2.2	3.8-2.2
* Dati generali					
Tipo di compressore		MITSUBISHI INVERTER COMPRESSOR			
Voltaggio	V	220V-240V/50Hz or 60Hz/1PH			
Corrente nominale	A	10.5	13.2	17.0	23.0
Fusibile di protezione	A	16	20	26	35
Volume	m ³	28-85	58-120	65-132	78-156
Portata d'acqua	m ³ /h	5.0	6.0	8.0	10.0
Perdite di carico circuito acqua	Kpa	15	18	20	25
Scambiatore di calore		Tubo di titanio attorcigliato in PVC			
Collegamento acqua	mm	50			
Numero di ventole		1			
Tipo di ventilazione		Orizzontale			
Velocità della ventola	RPM	450-650		(550-850)*2	
Potenza assorbita della ventola	W	35-130		(32-110)*2	
Pressione sonora (10m)	dB(A)	≤ 43	≤ 45	≤ 49	≤ 49
Pressione sonora (1m)	dB(A)	40-54	41-56	42-60	42-60
Gas refrigerante (R32)	g	1500	1900	2000	2600
CO2 equivalente	Ton	1.01	1.28	1.35	1.76
*Ingombro/Peso					
Peso netto	kg	98	117	128	130
Peso lordo	kg	113	135	146	148
Dimensione netta	mm	1050*450*870		1050*452*1295	
Dimensione dell'imballo	mm	1140*480*1010		1130*515*1430	

Dati tecnici per pompe di calore per piscine PRO ELYO INVERBOOST NN

Normativa CE, R410A, Struttura in ABS

MODELLO		Pro Elyo Inverboost NN26T	Pro Elyo Inverboost NN 35	Pro Elyo Inverboost NN35T
CODICE		68821	68822	68823
* Performance con Aria a 28°C, Acqua a 28°C, Umidità all'80%				
Capacità di	Kw	26-5.9	35-8	35-8
Consumo energetico	Kw	3.88-0.37	5.22-0.5	5.22-0.5
C.O.P.		16-6.7	16-6.7	16-6.7
* Performance con Aria a 15°C, Acqua a 26°C, Umidità al 70%				
Capacità di	Kw	18-5.4	24-5.6	24-5.6
Consumo energetico	Kw	3.6-0.68	4.8-0.68	4.8-0.68
C.O.P.		8.2-5	8.2-5	8.2-5
* Performance con Aria a 0°C, Acqua a 26°C, Umidità al 78%				
Capacità di	Kw	13-6.7	15.8-3.7	15.8-3.7
Consumo energetico	Kw	4.64-1.52	4.46-0.63	4.46-0.63
C.O.P.		4.4-2.8	5.8-3.6	5.8-3.6
* Performance con Aria a -10°C, Acqua a 26°C, Umidità al 78%				
Capacità di	Kw	10.4-5.9	11.6-3.1	11.6-3.1
Consumo energetico	Kw	4.73-1.51	4.77-0.6	4.77-0.6
C.O.P.		3.9-2.2	5.2-2.45	5.2-2.45
* Dati generali				
Tipo di compressore		MITSUBISHI INVERTOR COMPRESSOR		
Voltaggio	V	380V/50Hz or 60Hz/3PH	220~240V /50Hz or 60Hz/1PH	380V/50Hz or 60Hz/3PH
Corrente nominale	A	7	22.9	8.4
Fusibile di protezione	A	10.5	34	13
Volume	m ³	65-132	78-160	78-160
Portata d'acqua	m ³ /h	8.00	10.0	10.0
Perdite di carico circuito	Kpa	20	25	25
Scambiatore di calore		Tubo di titanio attorcigliato in PVC		
Collegamento acqua	mm	50		
Numero di ventole		2		
Tipo di ventilazione		Orizzontale		
Velocità della ventola	RPM	(550-850)*2		
Potenza assorbita della	W	(32-110)*2		
Pressione sonora (10m)	dB(A)	/	/	/
Pressione sonora (1m)	dB(A)	42-60	42-60	42-60
Gas refrigerante (R410a)	g	3800	4000	4000
CO2 equivalente	Tonn	7.94	8.36	8.36
*Ingombro/Peso				
Peso netto	kg	128		
Peso lordo	kg	146		
Dimensione netta	mm	1050*452*1295		
Dimensione dell'imballo	mm	1130*515*1430		

* Ci si riserva il diritto di apportare modifiche ai dati riportati nella tabella senza preavviso

4.1 Elenco accessori

		
Base anti-vibrazione, 4 pezzi	Tappo di drenaggio, 2 pezzi	Scatola impermeabile, 1 pezzo
		
Cavo di segnale da 10 m, 1 pezzo Cavo di segnale Modbus, 1 pezzo	Gruppo collegamento acqua, 2 set	Copertura invernale, 1 pezzo

4.2 Il Kit By-Pass

Il Kit By-Pass Kit è l'accessorio indispensabile per l'installazione della vostra pompa di calore, è nonché uno strumento che consente di ottimizzare il riscaldamento dell'acqua. La regolazione delle valvole consente di ottimizzarne la portata, mentre il manometro garantisce il miglior funzionamento del compressore.

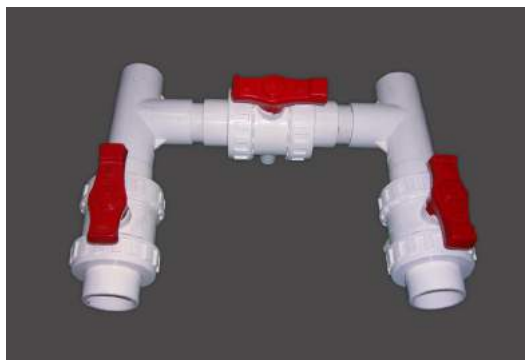

4.3 Accessori per l'installazione



Basi anti-vibrazione

1. Estraete le 4 basi anti-vibrazione
2. Inserirle una volta nella base dell'apparecchiatura.

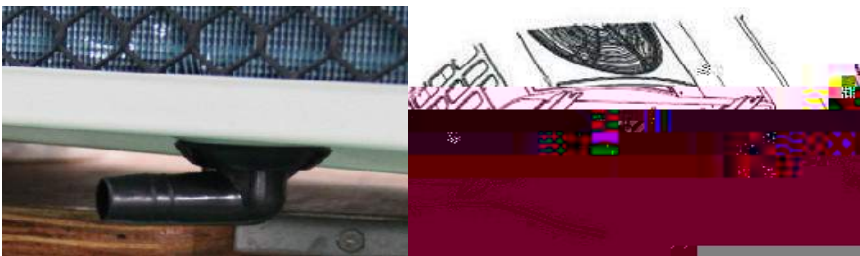

Collegamento del tappo di drenaggio

1. Installare il tappo di drenaggio sotto il pannello inferiore.
2. Collegare un tubo per far fuoriuscire l'acqua.

Nota: Sollevare la pompa di calore per installare il tappo. Non ribaltare mai la pompa di calore, si potrebbe danneggiare il compressore.



Entrata e uscita dell'acqua

1. Installare i due giunti come mostrato nell'immagine.
2. Avvitarli sulle prese dell'acqua (giunti di entrata e uscita).

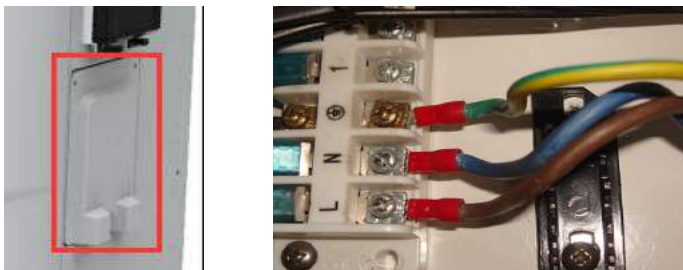

Cablaggio

1. Aprite il coperchio della morsettiera (contrassegnata in rosso) sul lato dell'apparecchiatura.
2. Collegare i cavi di alimentazione ai morsetti, come indicato nell'immagine.

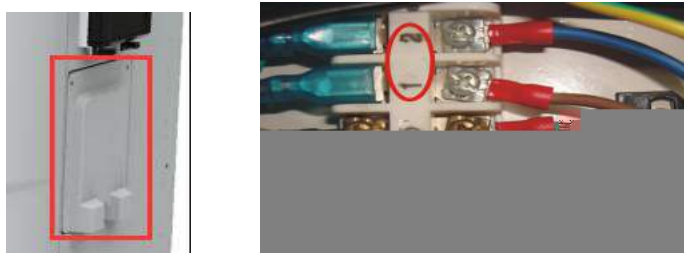

Cablaggio della pompa di filtrazione (Contatto privo di tensione)

1. Aprite il coperchio della morsettiera (contrassegnata in rosso) sul lato dell'apparecchiatura.
2. Collegare i cavi del sistema di filtrazione ai morsetti, come indicato nell'immagine.

ATTENZIONE:

Quando si installa la pompa di calore, si prega di osservare le seguenti indicazioni:

1. Qualsiasi aggiunta di prodotti chimici deve avvenire nella tubatura che si trova **a valle** della pompa di calore.
2. Appoggiare sempre la pompa di calore su una superficie robusta e piana. Per evitare vibrazioni e rumori utilizzare i supporti in gomma forniti in dotazione. Tenete sempre la pompa di calore in posizione verticale. Se l'unità è stata inclinata, attendete almeno 24 ore prima di metterla in funzione.

5.1 Posizionamento della pompa di calore

L'unità funzionerà adeguatamente in qualsiasi posizione purché siano presenti i seguenti tre fattori:

1. Aria pulita
2. Energia elettrica
3. Filtri per piscina

l'unità può essere installata in qualsiasi luogo all'esterno purché si mantengano le distanze minime stabilite rispetto ad altri oggetti (cfr. disegno qui sotto). Si prega di consultare il proprio installatore per un'installazione in una piscina coperta. A differenza dei riscaldatori a gas, è possibile installare le pompe di calore anche in un luogo ventoso senza alcun problema.

ATTENZIONE: Mai installare l'unità in una stanza chiusa con un volume d'aria limitato in cui l'aria espulsa dall'unità venga riutilizzata, o in prossimità di cespugli che potrebbero bloccare l'entrata dell'aria. Tali posizioni compromettono la fornitura continuativa di aria pulita, cagionando una ridotta efficienza e potendo impedire una sufficiente produzione di calore.

5.2 Verifica della valvola dell'impianto

NOTA

Nota: Se si utilizza un'apparecchiatura per il dosaggio automatico di cloro e acidità (pH), è fondamentale proteggere la pompa di calore contro concentrazioni chimiche eccessivamente alte che possono corrodere lo scambiatore di calore. Per questa ragione, un'apparecchiatura di questo tipo deve essere sempre posta sulla tubatura sul lato **a valle** della pompa di calore, e si consiglia di installare una valvola di ritenuta per evitare un'inversione di flusso in assenza di circolazione dell'acqua.

Eventuali danni alla pompa di calore derivanti dal mancato rispetto di queste istruzioni non verranno coperti da garanzia.

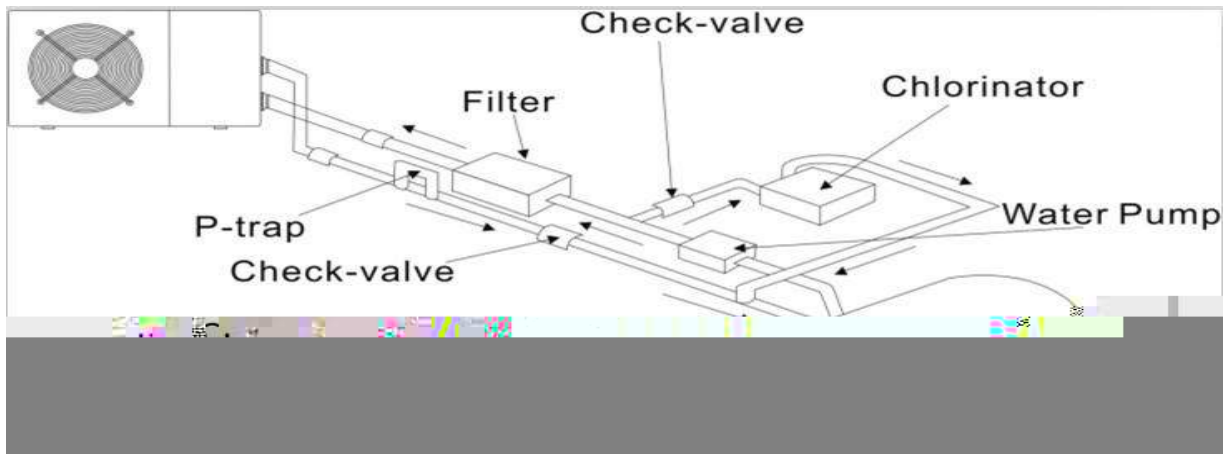

5.3 Disposizione tipica

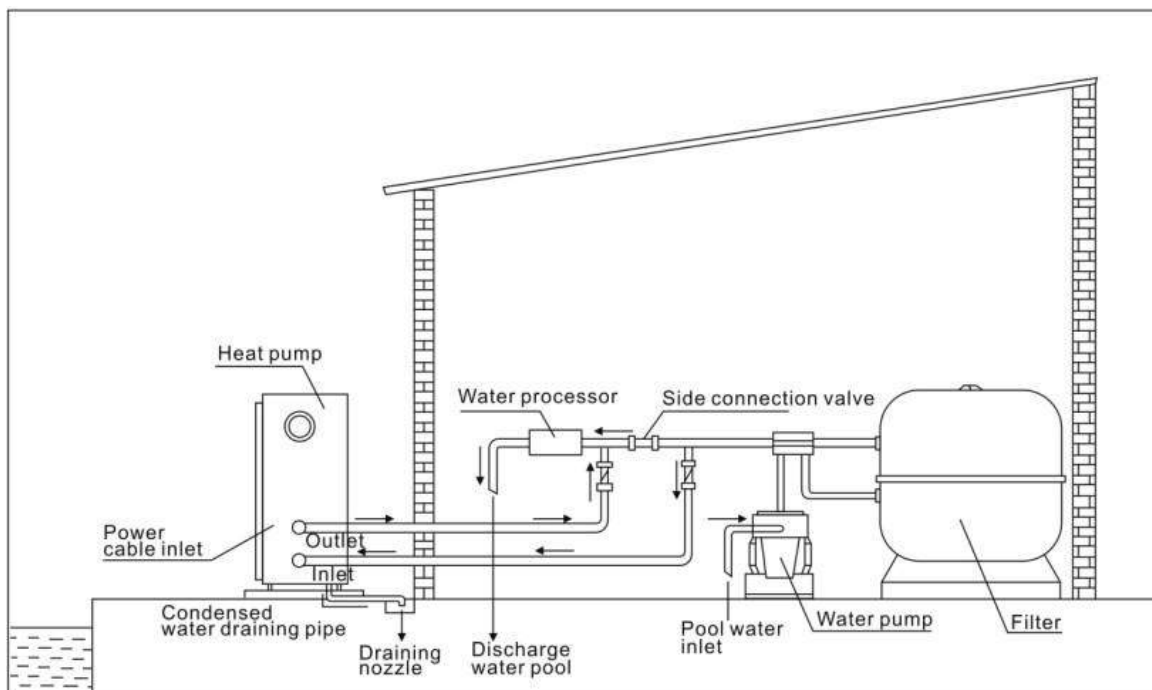

Questa disposizione è solo un esempio a titolo indicativo.

⚠️ NOTA

La fabbrica fornisce solo la pompa di calore. Tutti gli altri componenti, ivi compreso un bypass se del caso, devono essere forniti dall'utente o dall'installatore.

ATTENZIONE:

Per scaldare l'acqua presente nella piscina (o in una vasca da bagno), la pompa di filtrazione deve essere in funzionamento di modo che l'acqua circoli nella pompa di calore. La pompa di calore non si avvierà se l'acqua non sta circolando.

5.4 Messa in funzione

Una volta effettuati e verificati tutti i collegamenti, procedere come indicato di seguito:

1. Accendere la pompa di filtrazione. Controllare la presenza di eventuali perdite e verificare che l'acqua arrivi senza problemi nella e dalla piscina.

2. Alimentare la pompa di calore e premere il tasto On/Off  sul pannello di controllo elettronica. L'unità si avvierà una volta conclusosi il tempo di ritardo (vedi sotto).
3. Dopo pochi minuti, verificare che l'aria emessa dall'unità sia più fredda.
4. Quando la pompa di filtrazione si spegne, anche l'unità dovrebbe spegnersi automaticamente. Altrimenti, regolare successivamente il flussostato.

5. Consentire alla pompa di calore e alla pompa di filtrazione di funzionare 24 ore su 24 fino a che non sia raggiunta la temperatura dell'acqua desiderata. La pompa di calore cesserà di funzionare una volta raggiunta detta temperatura. Una volta avvenuto ciò, si riavvierà automaticamente (purché la pompa di filtrazione stia funzionando) e la temperatura dell'acqua della piscina scenda di 2 grado al di sotto della temperatura fissata (per esempio, se fissate la temperatura a 28°C, la pompa di calore si arresterà quando la temperatura sarà a 29°C. Mentre si riavvierà quando la temperatura dell'acqua scenderà a 27°C)

A seconda della temperatura iniziale dell'acqua presente nella piscina e della temperatura dell'aria, potrebbero occorrere diversi giorni per riscaldare l'acqua fino alla temperatura desiderata. Una buona copertura per piscina può accorciare il periodo di tempo richiesto.

NOTA

L'unità è munita di un flussostato che protegge la pompa di calore, regolando in modo adeguato la portata dell'acqua. Si accende durante il funzionamento della pompa della piscina è in funzionamento e si spegne in contemporanea alla pompa.

Tempo di ritardo – La pompa di calore integra un timer per la messa in funzione di 3 minuti la cui funzione è quella di proteggere il circuito ed evitare un'eccessiva usura. L'unità si riavvierà automaticamente una volta trascorso questo tempo di ritardo. Anche una breve interruzione di corrente attiverà questo ritardo di tempo per evitare l'immediato riavvio dell'unità. Ulteriori interruzioni dell'alimentazione durante questo periodo di ritardo non influiranno sulla durata di 3 minuti del ritardo.

5.5 Condensazione

La pompa di calore raffredda molto l'aria aspirata dalla medesima per riscaldare l'acqua della piscina, il che può generare condensa sulle alette dell'evaporatore.

NOTA

In caso di elevata umidità, la quantità di condensa può essere anche di diversi litri all'ora. Questo fatto viene talora erroneamente considerata una perdita d'acqua.

5.6 Manometro (R32)

Esaminare il manometro che indica la pressione del gas refrigerante presente nell'unità, la tabella sottostante mostra il normale valore di pressione del gas (R32) ad apparecchiatura spenta e ad apparecchiatura in funzionamento.

Condizione dell'unità	Spenta			
	Ambiente (°C)	-5~5	5~15	15~25
Temperatura acqua (°C)	/	/	/	/
Pressione manometro (Mpa)	0.59~0.85	0.85~1.18	1.18~1.59	1.59~2.1

Condizione dell'unità	In funzionamento				
	Temperatura ambiente (°C)	/	/	/	/
Temperatura acqua (°C)	10~15	15~20	20~25	25~30	30~35
Pressione manometro (Mpa)	1.1~1.6	1.3~1.8	1.5~2.1	1.7~2.4	1.9~2.7

6.1 Schema elettrico di una pompa di calore inverter

Rif. 71676/71677/71678/71679/71680

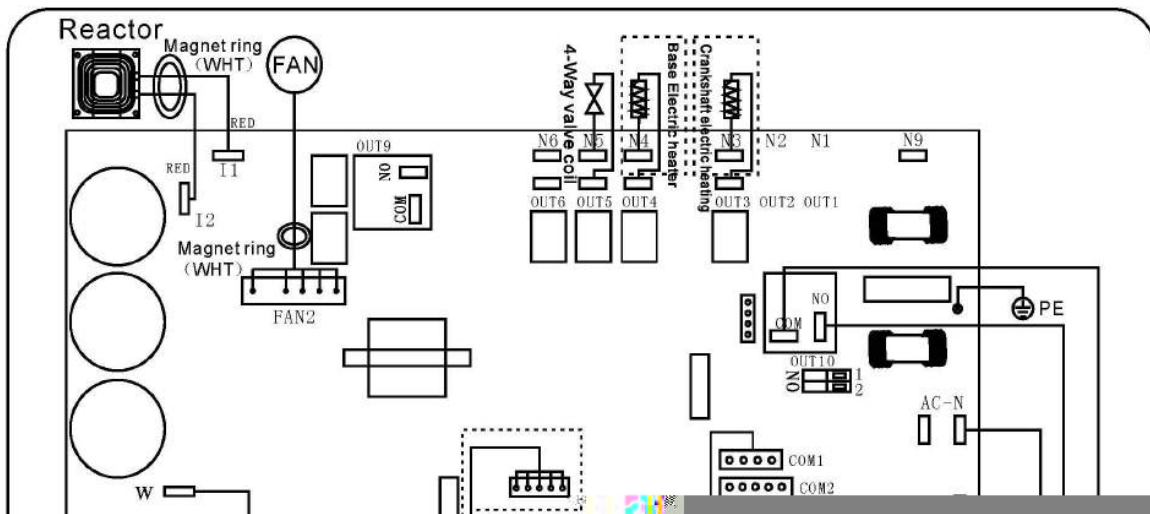

6.2 Schema elettrico di una pompa di calore inverter

Rif: 71681



6.3 Schema elettrico di una pompa di calore inverter

Rif: 71682/71683



6.4 Schema elettrico di una pompa di calore inverter

Rif. 68822 (R410A)

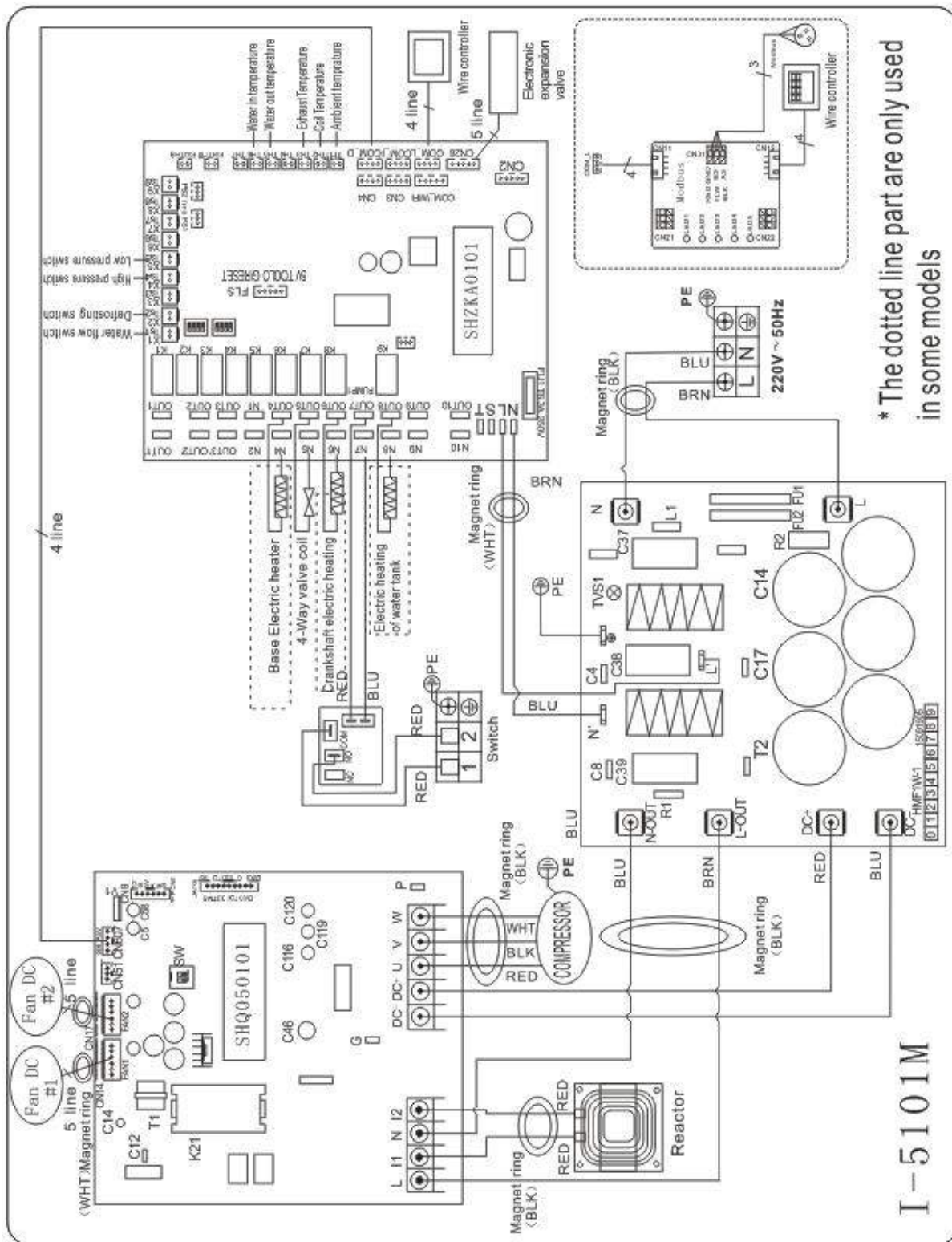

6.5 Schema elettrico di una pompa di calore inverter

Rif. 68821/68823 (R410A)

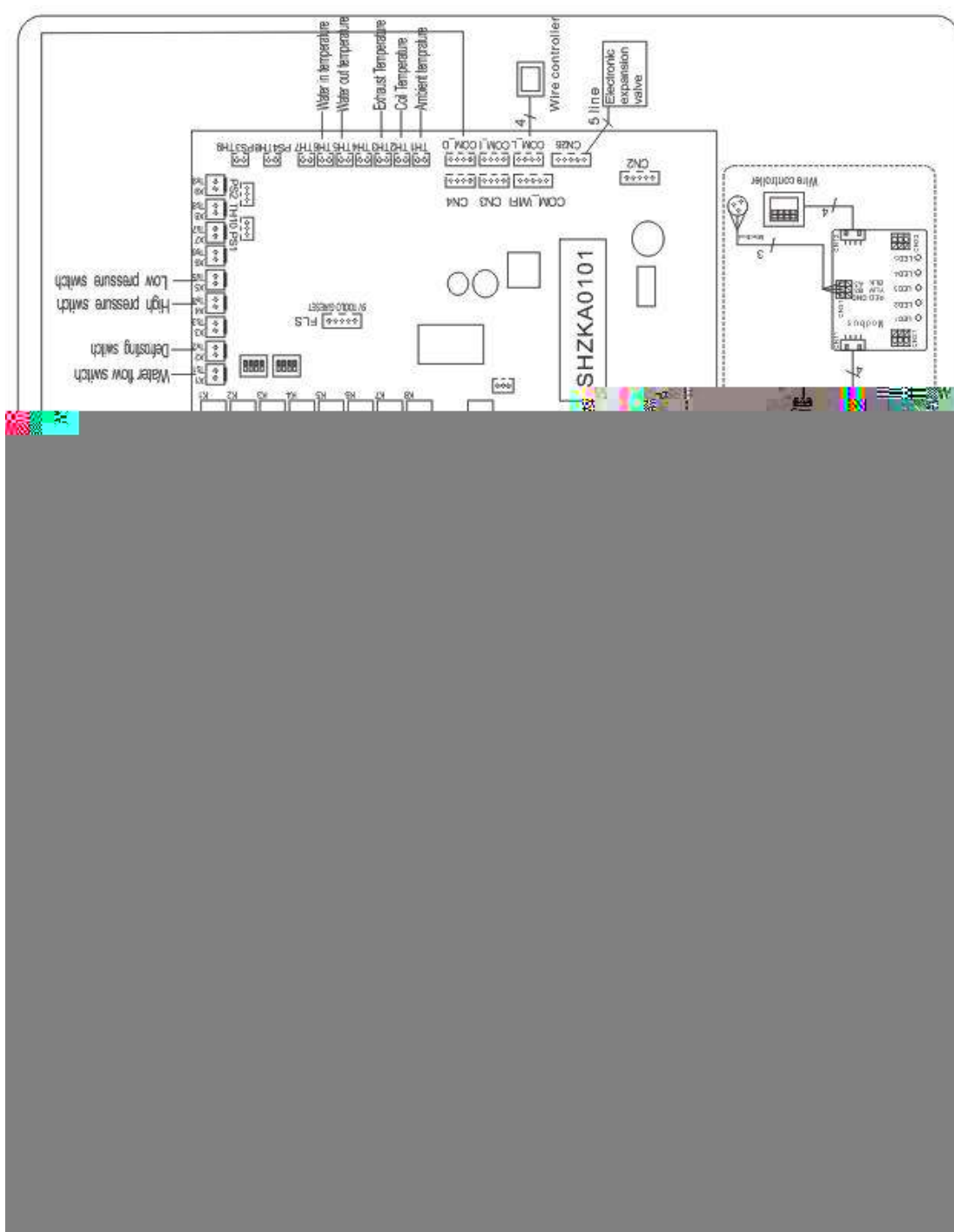

* Lo schema elettrico di cui sopra è solo vuol essere un semplice riferimento. Consultare sempre lo schema di cablaggio riportato sull'apparecchiatura.

6.6 Collegamento elettrico

L'alimentazione della pompa di calore deve avvenire, preferibilmente, da un circuito esclusivo con componenti tutelanti a livello normativo (protezione differenziale di 30mA) e un interruttore magneto-termico.

- L'installazione elettrica deve essere svolta da un professionista specializzato (un elettricista) nel rispetto delle norme e dei regolamenti in vigore nel Paese in cui avviene l'installazione.

- Il circuito della pompa di calore deve essere collegato a un circuito di mess

6.7 Installazione del display

Foto(1)



Foto(2)



Foto (3)

Foto (4)



Foto (5)

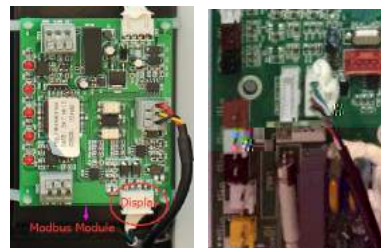

- Il terminale con spina di collegamento con il pannello di controllo (foto 1)
- L'altro terminale del cavo di segnale. (foto 2)
- Aprite il coperchio della scatola elettrica e farvi passare il cavo del display. (foto 3,4)
- Inserite il cablaggio nella posizione indicata sul display Modbus o sul PCB (senza Modbus). (foto 5)

6.8 Installazione del cavo di segnale Modbus/Fluidra Connect

Foto(6)



Foto(7)



Foto (8)



Foto(9)

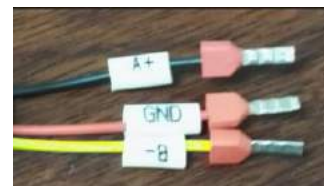

- Aprire il coperchio della scatola elettrica (foto 6)
- Prendere il cavo di segnale Modbus/Fluidra Connect degli accessori (foto7) e inserire il terminale arrotondato del cavo di segnale nel cavo di segnale Modulo Modbus/Fluidra Connect. (foto 8)
- Terminali trifilari: "A+" , "B- ", "GND" (foto 9)

ATTENZIONE:

Scollamento: occorre situare un dispositivo di scollamento (interruttore, fusibile o relè) in una posizione ben visibile e facilmente accessibile dall'unità. Tale prassi è piuttosto comune con le pompe di calore per uso commerciale e domestico. Di fatto, in questo modo si evita che all'impianto arrivi energia elettrica a distanza e si ha la possibilità di scollare la corrente nell'unità durante interventi di riparazione.

Timer di collegamento con contatto privo di tensione

Timer

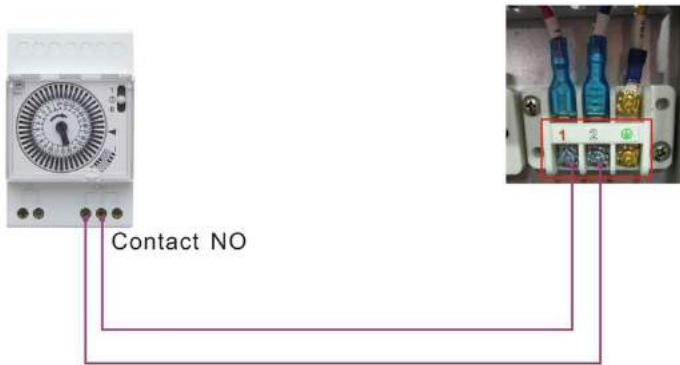

Collegamento della pompa con contatto privo di tensione

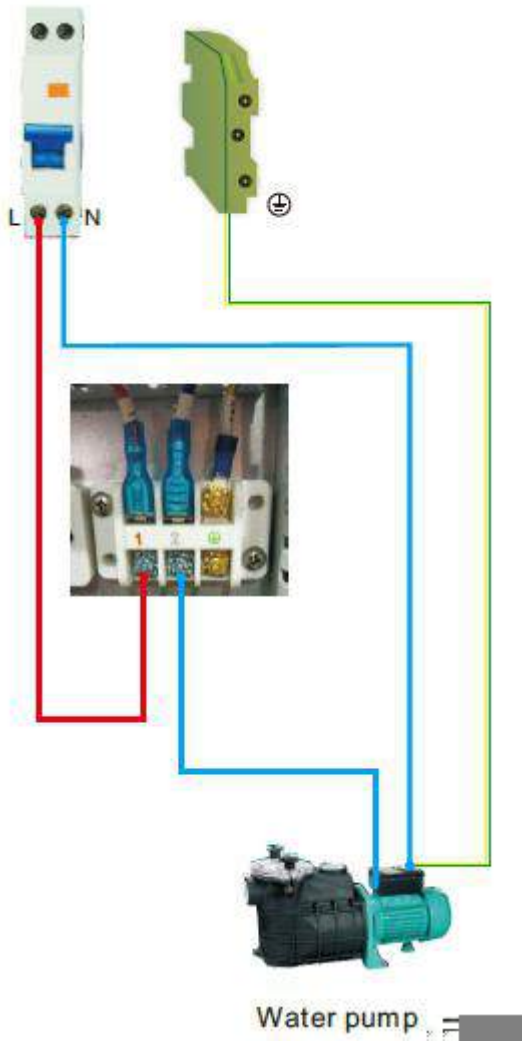

7. Funzionamento del controller

7.1. Guida operativa

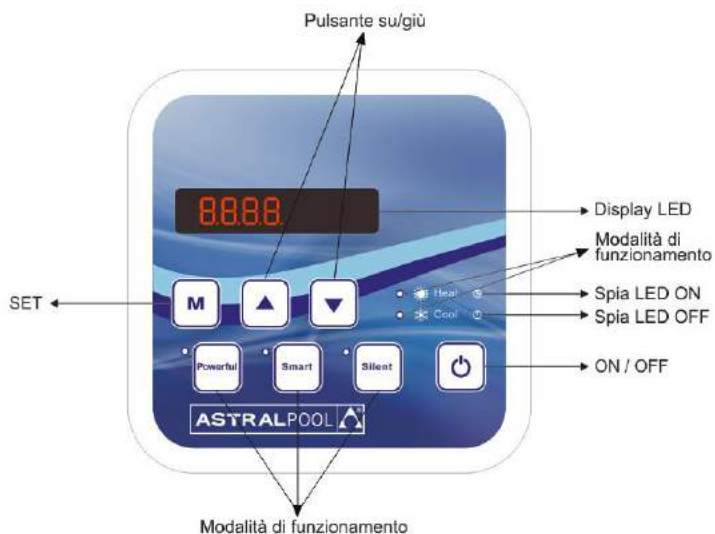



Quando si collega la pompa di calore alla corrente, il display a LED mostra per 3 secondi un codice che indica il modello di pompa di calore.

7.2 I tasti e le loro funzioni

7.2.1 Tasto

Premere  per avviare la pompa di calore, il display a LED mostra per 5 secondi la temperatura dell'acqua desiderata, quindi mostra la temperatura dell'acqua in entrata la modalità di funzionamento.

Premere  per arrestare la pompa di calore e mostrare "OFF"

Avvertenza: Nel corso della verifica e dell'impostazione dei parametri, premere il tasto  per uscire rapidamente e salvare le impostazioni correnti.

Premere nuovamente il tasto  per accendere/spegnere l'apparecchiatura.

7.2.2 Tasto

Premere il tasto  per 5 secondi per passare dalla modalità riscaldamento alla modalità automatica.

7.2.3 Premere il tasto e il tasto

Bloccare/Sbloccare il display:

Tenere premuti per 5 secondi il tasto  e il tasto

Verifica dei parametri:

Premere prima il tasto , e poi premere il tasto  per verificare il parametro Utente da d0 a d14

Codice	Condizione	Portata	Commento
d0	IPM temperatura dello stampo	0-120°C	Valore di test reale
d1	Temperatura dell'acqua in entrata T1	-9°C~99°C	Valore di test reale
d2	Temperatura dell'acqua in uscita T2	-9°C~99°C	Valore di test reale
d3	Temperatura ambiente T5	-30°C~70°C	Valore di test reale
d4	Codice di limitazione della frequenza	0,1,2,4,8,16	Valore di test reale
d5	Temperatura evaporatore T3	-30°C~70°C	Valore di test reale
d6	Temperatura scarico gas T6	0°C~C5°C (125°C)	Valore di test reale
d7	Passaggio di EEV	0~99	N*5
d8	Frequenza del funzionamento del compressore	0~99Hz	Valore di test reale
d9	Corrente del compressore	0~30A	Valore di test reale
d10	Velocità nominale delle ventola	0-1200 (rpm)	Valore di test reale
d11	Codice errore ultima volta	Tutto il codice i di errore	
d12	MOBUS COM	0 - 5	Impostazioni, solo Modbus
d13	Indirizzo ID MODBUS	1 - 88	Impostazioni, solo Modbus
d14	Codice prodotto	0000- FFFF	Impostazioni, solo Modbus

Commento: d4:Codice di limitazione della frequenza,

0: Nessun limite di frequenza;

1:Limite di temperatura del tubo della bobina;

2: Limite di frequenza di surriscaldamento o sovra raffreddamento;

4:Corrente limite di frequenza dell'unità;







8:Limite di frequenza della tensione di azionamento;

16:Limite di frequenza dell'alta temperatura di conduzione

Premere prima il tasto , quindi il tasto  per controllare/regolare il parametro Utente da P1 a P7



Codice	Nome	Portata	Default	Commento
P0	Sbrinamento obbligatorio	0-1	0	0: Funzionamento normale di default 1: sbrinamento obbligatorio.
P1	Modalità di funzionamento	0-1	1	1:Modalità riscaldamento, 0:modalità raffreddamento,
P2	Timer acceso/spento	0-1	0	1 il timer acceso/spento è in funzionamento, 0 il timer acceso/spento non è in funzione (l'impostazione P5 e P6 non funzionerà)
P3	Pompa dell'acqua	0-1	0	1: sempre in funzionamento; 0:dipende dal funzionamento del compressore
P4	Ora attuale	HH:MM	00: 00	<u>0-23:0-59</u>
P5	Timer attivato	HH:MM	00: 00	<u>0-23:0-59</u>
P6	Timer disattivato	HH:MM	00: 00	<u>0-23:0-59</u>
P7	Calibrazione temp acqua	-9~9	0	Impostazione di default: 0
P12	MOBUS COM	0 - 5	0	Solo Modbus (valore di default dopo il reset)
P13	Indirizzo ID MODBUS	1 - 88	9	Solo Modbus (valore di default dopo il reset)

Codice con connessione	Parametro P	Descrizione
71676	17FC	PAC PROELYXP07i 7-3.1Kw
71677	17FD	PAC PROELYXP09i 9-2.3Kw
71678	17FE	PROELYXP11i 11-2.9Kw
71679	17FF	PROELYXP14i 14-3.2Kw
71680	1800	PROELYXP16i 16-3.8Kw
71681	1801	PROELYXP20i 20-4.7Kw
71682	1802	PROELYXP26i 26-5.9Kw
71683	1803	PROELYXP30i 30-6.8Kw
68821	0CD5	PAC PROELYO INVERBOOST NN 26T 26-5.9Kw
68822	0CD6	PAC PROELYO INVERBOOST NN 35 35-8Kw
68823	0CD7	PAC PROELYO INVERBOOST NN 35T 35-8Kw

Parametro codice prodotto P (Solo Modbus): Premere i tasti  +  per 5 secondi, il primo numero digitale lampeggia, premere il tasto  o il tasto  per scegliere il numero target da 0-F, quindi premete il tasto  per regolare il secondo numero. Fare così anche per il terzo e il quarto numero. Infine premere  per salvare le impostazioni e uscire, o si uscirà automaticamente dopo 15 secondi.

Dopo aver effettuato l'impostazione, il parametro P del codice prodotto non potrà essere resettato, anche in caso di reset del sistema, il valore impostato verrà sempre mantenuto.

7.2.4 Funzione di reset del sistema

Premere il tasto  e il tasto  per 10 secondo, il sistema di resetterà e comparirà "0000" sul controller.

7.2.5 Heat

Simbolo di riscaldamento, la luce si accenderà quando è in funzionamento. Quando è in fase di sbrinamento, la luce lampeggerà.

7.2.6 Cool

Simbolo di raffreddamento, la luce si accenderà quando è in funzionamento.

7.2.7

Simbolo di arresto automatico, la luce si accenderà quando è in funzionamento.

7.2.8

Simbolo di avvio automatico, la luce si accenderà quando è in funzionamento.

7.2.9

Premere questo tasto, la luce lampeggerà, la pompa di calore funzionerà solo in modalità 'Full output'.



7.2.10

In modalità **Smart**, la pompa di calore funzionerà solo in modalità 'Medium output' e 'Full output'

Quando è in modalità 'Medium output', la spia Smart lampeggia.

Quando è in modalità 'Full output', la spia Smart è accesa, mentre la spia Powerful lampeggia.



7.2.11

In modalità **Silent**, la pompa di calore funzionerà solo in modalità 'Medium output' e 'Small output'

Quando è in modalità 'Small output', la spia Silent lampeggia.

Quando è in modalità 'Medium output', la spia Silent è accesa, mentre la spia Smart lampeggia.

7.2.12 Modalità automatica

L'unità prevede tre modalità: solo Riscaldamento, Modalità automatica (riscaldamento e raffreddamento), solo Raffreddamento.

Si può passare dalla modalità solo Riscaldamento alla modalità Automatica premendo per 5 secondi il tasto



, indipendentemente dal fatto che l'unità sia accesa o spenta.

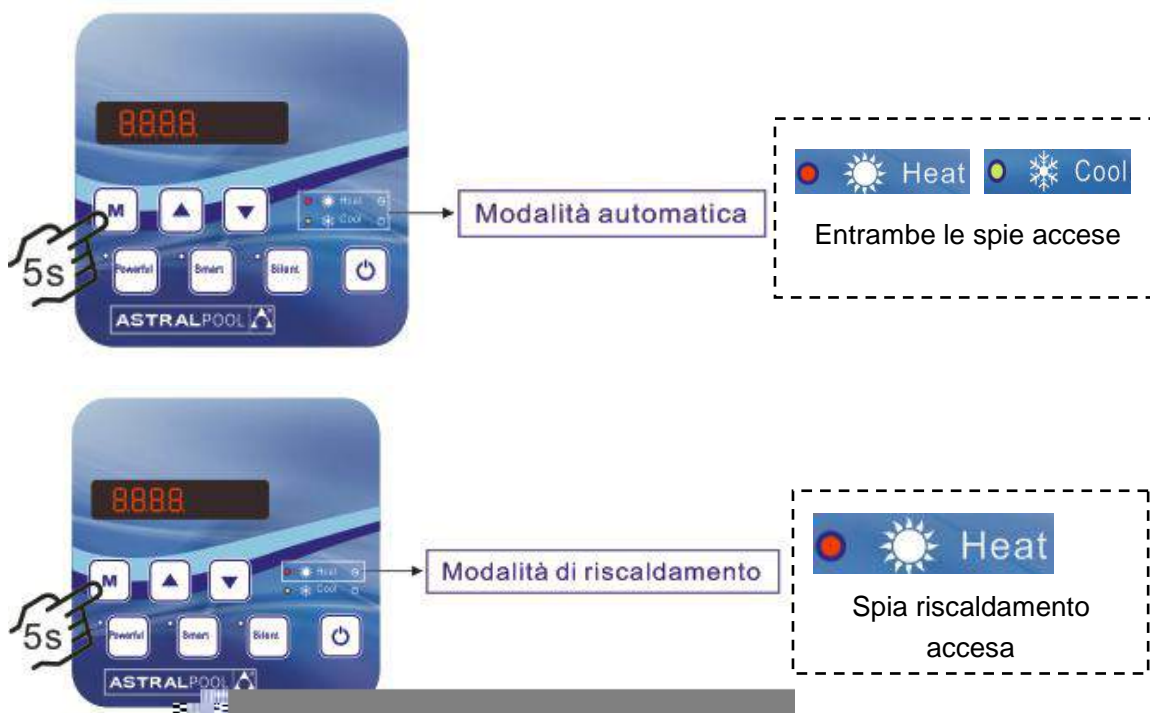

Logica di funzionamento della modalità Automatica

Opzione 1 La pompa di filtrazione è legata al funzionamento della pompa di calore in termini di avvio o arresto.

La pompa di filtrazione si avvia 60 secondi prima del compressore, la pompa di filtrazione si avvia per 30 secondi e poi il flussostato dell'acqua ne rileva la portata. Quando la pompa di calore entra in modalità stand-by, la pompa di filtrazione si arresta 60 secondi dopo l'arresto del compressore.

La pompa di filtrazione si riavvia per 3 minuti quindi si arresta quando il tempo di stand-by supera le 2 ore.

	Condizione	Esempio	Logica di funzionamento della pompa dell'acqua
Modalità riscaldamento	$T1 > T_{set-1}$, durata di 30 minuti	$T1 > 27^{\circ}\text{C}$, durata di 30 minuti	La pompa di filtrazione entra in modalità stand-by. Quando la pompa di calore si riavvia a fine ciclo (PSE) si riavvia anche la pompa di filtrazione.

7.3 Logica di funzionamento del riscaldamento

Stato del funzionamento		Modalità di funzionamento	Acqua in temperatura -T1	Ad esempio, acqua in temperatura -T1	Livello di funzionamento della pompa di calore
1	Avvio della pompa di calore	Quando si seleziona la "modalità di funzionamento Smart"	$T1 < Tset-1$	$T1 < 27^{\circ}C$	Modalità Powerful-frequenza F9
2			$Tset-1 \leq 1 < Tset$	$27^{\circ}C1 < 28^{\circ}C$	Frequenza: F9 -F8-F7,...,-F2
3			$Tset \leq T1 < Tset+ 1$	$28^{\circ}C \leq T1 < 29^{\circ}C$	Modalità Silent-frequenza F2
4			$T1 \geq Tset+1$	$T1 \leq 29^{\circ}C$	La pompa di calore rimarrà in modalità Standby, e non funzionerà fino a quando l'acqua non scende sotto i 28°C.
5		Quando si seleziona la "modalità di funzionamento Silent"	$T1 < Tset$	$T1 < 28^{\circ}C$	Modalità Smart-frequenza F5.
6			$Tset \leq T1 < Tset+1$	$28^{\circ}C \leq T1 < 29^{\circ}C$	Modalità Silent-frequenza F2/F1.
7			$T1 \geq Tset+1$	$T1 \geq 29^{\circ}C$	La pompa di calore rimarrà in modalità Standby, e non funzionerà fino a quando l'acqua non scende sotto i 28°C.
8		Quando si seleziona la "modalità di funzionamento Powerful"	$T1 < Tset+1$	$T1 < 29^{\circ}C$	Modalità Powerful-frequenza F10/F9
9			$T1 \geq Tset+1$	$T1 \geq 29^{\circ}C$	La pompa di calore rimarrà in modalità Standby, e non funzionerà fino a quando l'acqua non scende sotto i 28°C.
10	Riavvio per riscaldare l'acqua nello stato di stand-by	Quando la pompa di calore funziona in "Modalità Smart"	$T1 \geq Tset$	$T1 \geq 28^{\circ}C$	Standby
11			$Tset > T1 \geq Tset-1$	$28^{\circ}C > T1 \geq 27^{\circ}C$	Silent-frequenza F2
12			$Tset-1 > T1 \geq Tset-2$	$27^{\circ}C > T1 \geq 26^{\circ}C$	Frequenza: F2 -F3-F4,...,-F9
13			$< Tset-2$	$< 26^{\circ}C$	Powerful-frequenza F9
14		Quando la pompa di calore funziona in "Modalità Silent"	$\geq Tset$	$\geq 28^{\circ}C$	Standby
15			$Tset > T1 \geq Tset-1$	$28^{\circ}C > T1 \geq 27^{\circ}C$	Modalità Silent-frequenza F2/F1
16			$T1 < Tset-1$	$T1 < 27^{\circ}C$	Smart-frequenza F5
17	Quando la pompa di calore funziona in "Modalità Powerful"	$T1 < Tset-1$	$T1 < 27^{\circ}C$	Powerful-frequenza F10/F9	

7.4 Logica di funzionamento del raffreddamento

Stato del funzionamento		Modalità di funzionamento	Acqua in temperatura -T1	Ad esempio, acqua in temperatura -T1	Livello di funzionamento della pompa di calore
1	Avvio della pompa di calore	Quando si seleziona la "modalità di funzionamento Smart"	$T1 \leq T_{set}-1$	$T1 \leq 27^{\circ}\text{C}$	Standby.
2			$T_{set}-1 < T1 \leq T_{set}$	$27^{\circ} < T1 \leq 28^{\circ}\text{C}$	Modalità Silent-frequenza F2
3			$T_{set} < T1 \leq T_{set}+1$	$28 < T1 \leq 29^{\circ}\text{C}$	Frequenza: F9 -F8-F7,...,- F2
4			$T1 \geq T_{set}+1$	$T1 \geq 29^{\circ}\text{C}$	Modalità Powerful-frequenza -F9
5		Quando si seleziona la "modalità di funzionamento Silent"	$T1 \leq T_{set}-1$	$\leq 27^{\circ}\text{C}$	Standby
6			$T_{set}-1 < T1 \leq T_{set}$	$27^{\circ}\text{C} < T1 \leq 28^{\circ}\text{C}$	Modalità Silent-frequenza F2/F1
7			$T1 > T_{set}$	$T1 > 28^{\circ}\text{C}$	Modalità Smart-frequenza F5
8		Quando si seleziona la "modalità di funzionamento Powerful"	$T1 > T_{set}-1$	$T1 > 27^{\circ}\text{C}$	Modalità Powerful-frequenza F10/F9
9			$T1 \leq T_{set}-1$	$T1 \leq 27^{\circ}\text{C}$	Standby
10	Riavvio per raffreddare l'acqua nello stato di Stand-by	Smart	$T1 \leq T_{set}-1$	$T1 \leq 27^{\circ}\text{C}$	Standby
11			$T_{set} \leq T1 < T_{set}+1$	$28 \leq T1 < 29^{\circ}\text{C}$	Silent-frequenza F2
12			$T_{set}+1 \leq T1 < T_{set}+2$	$29 \leq T1 < 30^{\circ}\text{C}$	Frequenza: F2 -F3-F4,...,- F9
13			$T1 \geq T_{set}+2$	$T1 \geq 30^{\circ}\text{C}$	Modalità Powerful-frequenza F9
14		Silent	$T_{set} < T1 \leq T_{set}+1$	$28 < T1 \leq 29^{\circ}\text{C}$	Modalità Silent-frequenza F2/F1
15			$T1 > T_{set}+1$	$T1 > 29^{\circ}\text{C}$	Modalità Smart-frequenza F5
16		Powerful	$T1 > T_{set}+1$	$T1 > 29^{\circ}\text{C}$	Modalità Powerful-frequenza F10/F9
17	$T1 \leq T_{set}-1$		$T1 \leq 27^{\circ}\text{C}$	Standby	

8.1 Visualizzazione del codice di errore sul controller LED

Problema	Codice	Causa	Soluzione
Errore della sonda di temperatura dell'acqua in entrata T1-TH6	PP01	1. Sonda in circuito aperto o in corto circuito 2. Il cablaggio della sonda è allentato	1. Verificare o sostituire la sonda 2. Riparare il cablaggio delle sonde
Errore della sonda di temperatura dell'acqua in uscita T2-TH5	PP02	1. Sonda in circuito aperto o in corto circuito 2. Il cablaggio della sonda è allentato	1. Verificare o sostituire la sonda 2. Riparare il cablaggio delle sonde
Errore della sonda dell'evaporatore T3-TH2	PP03	1. Sonda in circuito aperto o in corto circuito 2. Il cablaggio della sonda è allentato	1. Verificare o sostituire la sonda 2. Riparare il cablaggio delle sonde
Errore della sonda di aspirazione del compressore	PP04	1. Sonda in circuito aperto o in corto circuito 2. Il cablaggio della sonda è allentato	1. Verificare o sostituire la sonda 2. Riparare il cablaggio delle sonde
Errore della sonda di temperatura ambiente T5-TH1	PP05	1. Sonda in circuito aperto o in corto circuito 2. Il cablaggio della sonda è allentato	1. Verificare o sostituire la sonda 2. Riparare il cablaggio delle sonde
Errore della sonda di tuberia di scarico del compressore T6-TH3	PP06	1. Sonda in circuito aperto o in corto circuito 2. Il cablaggio della sonda è allentato	1. Verificare o sostituire la sonda 2. Riparare il cablaggio delle sonde
Protezione antigelo in inverno	PP07	La temperatura ambiente o dell'acqua in entrata è troppo bassa	Protezione normale
Protezione per bassa temperatura ambiente	PP08	1. L'ambiente è al di fuori dell'ambito di uso 2. Anomalia della sonda	1. Smettere di utilizzare fuori dall'ambito di uso 2. Sostituire la sonda
Temperatura del condensatore. Eccessiva in modalità raffreddamento T3-TH2	PP10	1. Temperatura ambiente o temperatura dell'acqua troppo elevata in modalità raffreddamento 2. Il sistema refrigerante è anomalo	1. Verificare l'ambito di utilizzo 2. Verificare il sistema refrigerante
Protezione per temperatura dell'acqua. Molto bassa in modalità raffreddamento T2-TH5	PP11	1. Portata d'acqua ridotta 2. Anomalia della sonda di temperatura T2-TH5	1. Verificare la pompa di filtrazione e il circuito dell'acqua 2. Sostituire la sonda di temperatura T2-TH5
Errore di alta pressione TS4	EE01	1. La temperatura ambiente è troppo alta il mini-pressostato di alta pressione non è ben collegato o è guasto. 2. La temperatura dell'acqua è troppo alta 3. La portata dell'acqua è insufficiente. 4. La velocità della ventola è anomala o il motoventilatore ha subito dei danni.	1. Verificare il cablaggio del mini-pressostato di alta pressione o sostituirlo. 2. Controllare il motoventilatore. 3. Verificare e riparare il sistema di tubazioni.

Problema	Codice	Causa	Soluzione
Errore di bassa pressione TS5	EE02	<ol style="list-style-type: none"> 1. Il mini-pressostato di bassa pressione non è ben collegato o è guasto. si è bloccato o il sistema di tubazioni è otturato 2. La velocità del motore è anomala o il motore è danneggiato 3. Fuga di gas 	<ol style="list-style-type: none"> 1. Verificare l'EEV e il sistema di tubazioni Verificare il motore 2. Attraverso il manometro di alta pressione per verificare il valore della pressione 3. Verificare il sistema refrigerante
Errore nella portata dell'acqua TS1	EE03 o "ON"	<ol style="list-style-type: none"> 1. Il flussostato dell'acqua non è ben collegato o è danneggiato 2. Portata dell'acqua assente/insufficiente. 	<ol style="list-style-type: none"> 1. Verificare il cablaggio del flussostato dell'acqua o sostituirlo 2. Verificare la pompa di filtrazione o il circuito dell'acqua
Protezione da surriscaldamento della temperatura dell'acqua (T2-TH5) in modalità riscaldamento	EE04	<ol style="list-style-type: none"> 1. Portata dell'acqua ridotta 2. Il flussostato dell'acqua è bloccato e la fornitura d'acqua è stata interrotta 3. Anomalia della sonda T2-TH5 	<ol style="list-style-type: none"> 1. Verificare il circuito dell'acqua 2. Controllare la pompa di filtrazione o l'Flussostato dell'acqua 3. Controllare la sonda T2-TH5 o sostituirla
Temperatura di scarico del compressore troppo alta T6-TH3	EE05	<ol style="list-style-type: none"> 1. Mancanza di gas 2. Portata dell'acqua ridotta 3. Il sistema di tubazioni è bloccato 4. Guasto della sonda T6-TH3 	<ol style="list-style-type: none"> 1. Controllare il manometro di alta pressione, se ha un livello insufficiente, aggiungere gas 2. Verificare il circuito dell'acqua e la pompa di filtrazione 3. Verificare il sistema di tubazioni per vedere se esistono ostruzioni 4. Sostituire la sonda T6-TH3
Errore del controller	EE06	<ol style="list-style-type: none"> 1. La connessione del cavo non è corretta, o il cavo di segnale è danneggiato 2. Guasto del controller 	<ol style="list-style-type: none"> 1. Controllare e ricollegare il cavo di segnale 2. Sostituire il cavo di segnale 3. Interrompere l'alimentazione e riavviare la macchina 4. Sostituire il controller
Protezione del consumo del compressore	EE07	<ol style="list-style-type: none"> 1. La corrente del compressore è eccessiva istantaneamente 2. Connessione errata per la sequenza di fase del compressore 3. Accumuli di liquidi e olio nel compressore fanno aumentare la corrente 4. Compressore o scheda madre danneggiati 5. Portata dell'acqua anomala 6. Fluttuazioni di corrente in poco tempo 	<ol style="list-style-type: none"> 1. Verificare il compressore e le fasi. 2. Verificare che la potenza sia nella norma 3. Verificare il collegamento della sequenza di fase 4. Verificare il circuito dell'acqua e la pompa di filtrazione 5. Verificare la principale fonte di energia

Problema	Codice	Causa	Soluzione
Errore di comunicazione tra il controller e la scheda principale	EE08	<ol style="list-style-type: none"> 1. Collegamento del cavo di segnale debole o cavo di segnale danneggiato 2. Guasto del controller 	<ol style="list-style-type: none"> 1. Controllare e ricollegare il cavo di segnale 2. Sostituire il cavo di segnale 3. Interrompere l'alimentazione elettrica e riavviare la pompa 4. Sostituire il controller
Errore di comunicazione tra la scheda principale e la scheda del driver	EE09	<ol style="list-style-type: none"> 1. Collegamento del cavo di comunicazioni debole 2. Il cavo è danneggiato 	<ol style="list-style-type: none"> 1. Verificare il collegamento del cavo 2. Sostituire il cavo
Protezione VDC. Tensione eccessiva	EE10	<ol style="list-style-type: none"> 1. La tensione della linea della scheda madre è troppo alta 2. Il controller è danneggiato 	<ol style="list-style-type: none"> 1. Verificare che la potenza rientri nell'intervallo normale 2. sostituire il controller
Protezione modulo IPM	EE11	<ol style="list-style-type: none"> 1. Errore di dati 2. Errata connessione di fase del compressore 3. Un accumulo di liquidi o olio nel compressore fanno aumentare la corrente 4. Compressore o controller danneggiati 	<ol style="list-style-type: none"> 1. Errore di programma, spegnere l'alimentazione e riavviare dopo 3 minuti 2. Sostituire il controller 3. Verificare la connessione di sequenza del compressore
Protezione di bassa tensione di VDC	EE12	<ol style="list-style-type: none"> 1. La tensione della tensione madre è troppo bassa 2. Il controller è danneggiato 	<ol style="list-style-type: none"> 1. Verificare se la potenza rientra nell'intervallo normale 2. sostituire la scheda di controllo
Protezione contro sovrintensità	EE13	<ol style="list-style-type: none"> 1. La corrente del compressore è momentaneamente eccessiva 2. Anomalia nella portata dell'acqua 3. Fluttuazione di energia in poco tempo 4. Errato induttore PFC 	<ol style="list-style-type: none"> 1. Verificare il compressore 2. Verificare il sistema di tubazioni 3. Verificare che la potenza rientri nell'intervallo normale 4. Verificare che si stia utilizzando l'induttore PFC corretto
Errore di uscita del circuito di rilevamento della temperatura del modulo IPM	EE14	<ol style="list-style-type: none"> 1. Uscita fuori dalla norma del circuito termico del modulo IPM 2. Anomalia o guasto del motoventilatore 3. Pala della ventola rotta 	<ol style="list-style-type: none"> 1. Sostituire il controller 2. Verificare se la velocità del motore è troppo bassa e se il motoventilatore è danneggiato, eventualmente sostituirlo 3. Sostituire la palla della ventola 4. Verificare la tensione di ingresso

Problema	Codice	Causa	Soluzione
Protezione della temperatura alta del modulo IPM	EE15	<ol style="list-style-type: none"> 1. Eccezione di uscita del circuito termico del modulo IPM 2. Il motore è anormale o danneggiato 3. Pala della ventola rotta 	<ol style="list-style-type: none"> 1.Sostituire il controller 2.Verificare se la velocità del motore del ventilatore è insufficiente o se il motoventilatore è danneggiato, sostituirlo 3.Sostituire la pala della ventola
Protezione del modulo PFC	EE16	<ol style="list-style-type: none"> 1. Eccezione di uscita del modulo PFC 2. Anomalia o danno del motore 3. La pala della ventola rotta 4. Salto di nel voltaggio di ingresso, anomalia della potenza di ingresso 	<ol style="list-style-type: none"> 1.Sostituire il controller 2.Verificare se la velocità del motore è insufficiente o il motoventilatore è danneggiato, eventualmente sostituirlo 3. Sostituire la pala della ventola 4. Verificare la tensione di ingresso
Guasto motore ventilatore DC	EE17	<ol style="list-style-type: none"> 1. Il motore CC è danneggiato 2. Il controller è danneggiato 3. La pala della ventola è bloccata 	<ol style="list-style-type: none"> 1.Individuare il motore DC e sostituirlo 2.Sostituire il controller 3. Individuare l'ostacolo ed eliminarlo
Anomalia nel funzionamento del modulo PFC	EE18	La scheda di controllo è danneggiata	<ol style="list-style-type: none"> 1.Sostituire il controller 2. Verificare se la velocità del motore del ventilatore è insufficiente o il motoventilatore è danneggiato, eventualmente sostituirlo
Errore per alta temperatura del modulo PFC	EE19	<ol style="list-style-type: none"> 1. Anomalia nell'uscita del circuito termico del modulo PFC 2. Anomalia o danno nel motore 3. Pala della ventola 4. Vite della scheda di controllo allenata 	<ol style="list-style-type: none"> 1.Sostituire il controller 2.Verificare se la velocità del motore è insufficiente o il motoventilatore è danneggiato, eventualmente sostituirlo 3. Sostituire la pala della ventola 4.Verificare che la vite non sia allenata
Errore nell'alimentazione di ingresso	EE20	Il voltaggio della sorgente di alimentazione oscilla eccessivamente	Verificare la stabilità del voltaggio

Problema	Codice	Causa	Soluzione
Errore nel controllo del software	EE21	<ol style="list-style-type: none"> 1. Il compressore va fuori giri 2. Programma errato 3. Delle impurità all'interno del compressore causano una velocità di rotazione instabile 	<ol style="list-style-type: none"> 1. Verificare o sostituire il controller 2. Inserire il programma corretto
Errore di circuito nel rilevamento della corrente	EE22	<ol style="list-style-type: none"> 1. Segnale di tensione anomalo 2. Controller danneggiato 	<ol style="list-style-type: none"> 1. Verificare o sostituire il controller 2. Sostituire il controller
Errore all'avvio del compressore	EE23	<ol style="list-style-type: none"> 1. Il controller è danneggiato 2. Errore nel cablaggio del compressore , scarso contatto o mancato collegamento 3. Accumulo di liquido all'interno 4. Errata connessione di fase per il compressore 	<ol style="list-style-type: none"> 1. Verificare o sostituire il controller 2. Verificare il cablaggio del compressore secondo lo schema elettrico 3. Controllare il compressore o sostituirlo
Errore del dispositivo di temperatura ambiente nella scheda elettronica	EE24	Errore del dispositivo di temperatura ambiente	Sostituire la scheda del controller o la scheda principale
Errore nella fase del compressore	EE25	Connessione scadente delle fasi U,V e W	Verificare l'attuale cablaggio confrontandolo con lo schema elettrico
Errore della valvola a 4 vie	EE26	<ol style="list-style-type: none"> 1. Errore della valvola a 4 vie 2. Mancanza di refrigerante (non la rileva in caso di T3-TH2 o T5-TH1) 	<ol style="list-style-type: none"> 1. Passare alla modalità raffreddamento per verificare se la valvola a 4 vie si è invertita correttamente 2. Sostituire la valvola a 4 vie 3. Caricare gas
Errore di lettura dei dati sulla EEPROM	EE27	<ol style="list-style-type: none"> 1. Dati EEPROM errati nel programma o errore di inserimento dei dati EEPROM 2. Errore della scheda principale 	<ol style="list-style-type: none"> 1. Inserire i dati corretti EEPROM 2. Sostituire il controller
Errore di comunicazione nel chip interno della scheda elettronica	EE28	Errore della scheda principale	<ol style="list-style-type: none"> 1. Spegnerne l'alimentazione elettrica e riavviare 2. Sostituire la scheda principale

Commenti:

1. In modalità riscaldamento, se la temperatura dell'acqua in uscita è più elevata rispetto alla temperatura impostata di oltre 7°C, il controller LED mostra un errore EE04 per protezione da surriscaldamento dell'acqua.

In modalità raffreddamento, se la temperatura dell'acqua in uscita è più bassa rispetto alla temperatura impostata di oltre 7°C, il controller LED mostra un errore PP11 per protezione da sovraraffreddamento dell'acqua.

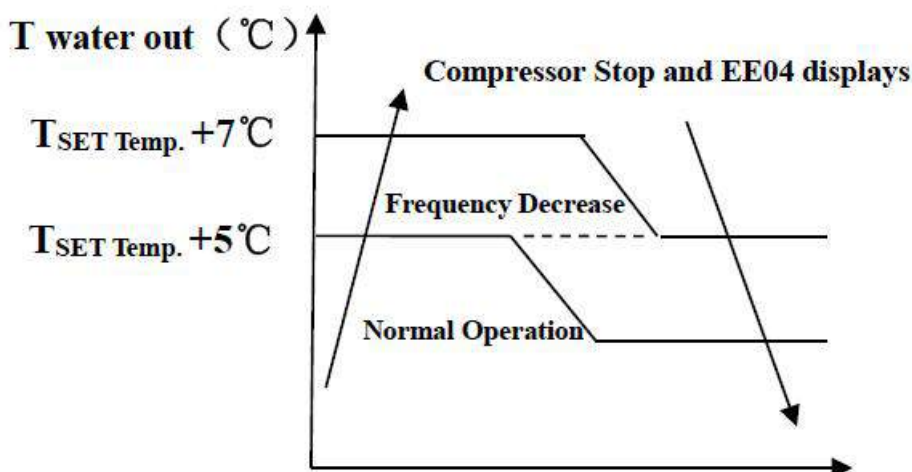

EE04 Protezione da surriscaldamento dell'acqua in uscita

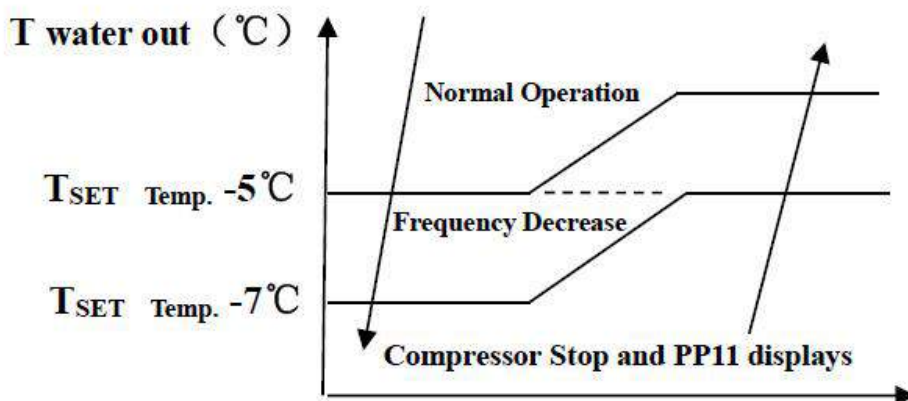

PP11 Protezione da sovra raffreddamento dell'acqua in uscita

Per un esempio si veda a seguire:

Modalità	Temperatura acqua in uscita	Impostazione temperatura	Condizione	Errore
Modalità riscaldamento	36°C	29°C	$T_{out} - T_{set} \geq 7^{\circ}\text{C}$	EE04 Protezione da surriscaldamento per temperatura dell'acqua (T2)
Modalità raffreddamento	23°C	30°C	$T_{set} - T_{out} \geq 7^{\circ}\text{C}$	PP11 Protezione insufficiente per temperatura dell'acqua (T2)

8.2 Altri guasti e soluzioni (non viene mostrato nulla sul controller LED)

Problema	Si Osserva	Causa	Soluzione
Pompa di calore non funzionante	Non viene mostrato nulla sul controller LED	Nessuna alimentazione	Verificare che il cavo e l'interruttore siano collegati
	Il controller LED mostra il tempo attuale.	Pompa di calore in modalità stand-by	Avviare la pompa di calore per metterla in funzione
	Il controller LED wire mostra l'attuale temperatura dell'acqua.	<ol style="list-style-type: none"> 1. La temperatura dell'acqua sta raggiungendo il valore impostato, pompa di calore in modalità di temperatura costante. 2. La pompa di calore ha appena iniziato a funzionare. 3. In fase di sbrinamento. 	<ol style="list-style-type: none"> 1. Verificare l'impostazione della temperatura dell'acqua. 2. Avviare la pompa di calore dopo alcuni minuti. 3. Il controller LED deve mostrare "Sbrinamento".
La temperatura dell'acqua si raffredda mentre la pompa di calore funziona in modalità riscaldamento	Il controller LED mostra l'attuale temperatura dell'acqua e il codice errore	<ol style="list-style-type: none"> 1. È stata scelta la modalità sbagliata. 2. Le cifre mostrano i problemi. 3. Guasto del controller. 	<ol style="list-style-type: none"> 1. Regolare la modalità per un adeguato funzionamento 2. sostituire il controller LED difettoso, e verificare lo stato dopo aver cambiato modalità di funzionamento, controllando la temperatura dell'acqua in entrata e in uscita. 3. Sostituire o riparare la pompa di calore
Breve funzionamento	Il controller LED mostra l'attuale temperatura dell'acqua, non appare il codice di errore	<ol style="list-style-type: none"> 1. Ventilatore NON funzionante. 2. La ventilazione dell'aria non è sufficiente. 3. Il refrigerante non è sufficiente. 	<ol style="list-style-type: none"> 1. Verificare le connessioni dei cavi tra motore e ventilatore, se necessario, sostituire. 2. Verificare la posizione della pompa di calore, ed eliminare tutti gli ostacoli che impediscono una buona circolazione dell'aria. 3 Sostituire o riparare la pompa di calore.
Macchie di acqua	Macchie d'acqua sulla pompa di calore	<ol style="list-style-type: none"> 1. Protezione 2. Perdita d'acqua. 	<ol style="list-style-type: none"> 1. Nessuna azione. 2. Controllare con attenzione lo scambiatore di calore in titanio per escludere eventuali fughe
Eccesso di ghiaccio nell'evaporatore	Eccesso di ghiaccio nell'evaporatore		<ol style="list-style-type: none"> 1. Verificare la posizione della pompa di calore, ed eliminare tutti gli ostacoli che impediscono una buona circolazione dell'aria. 2. Sostituire o riparare la pompa di calore.

9. 1 Esploso e manutenzione

Modello: 71676

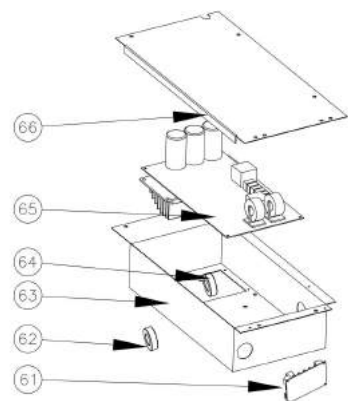
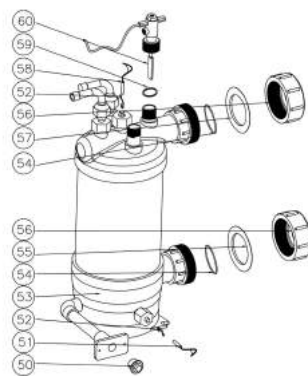
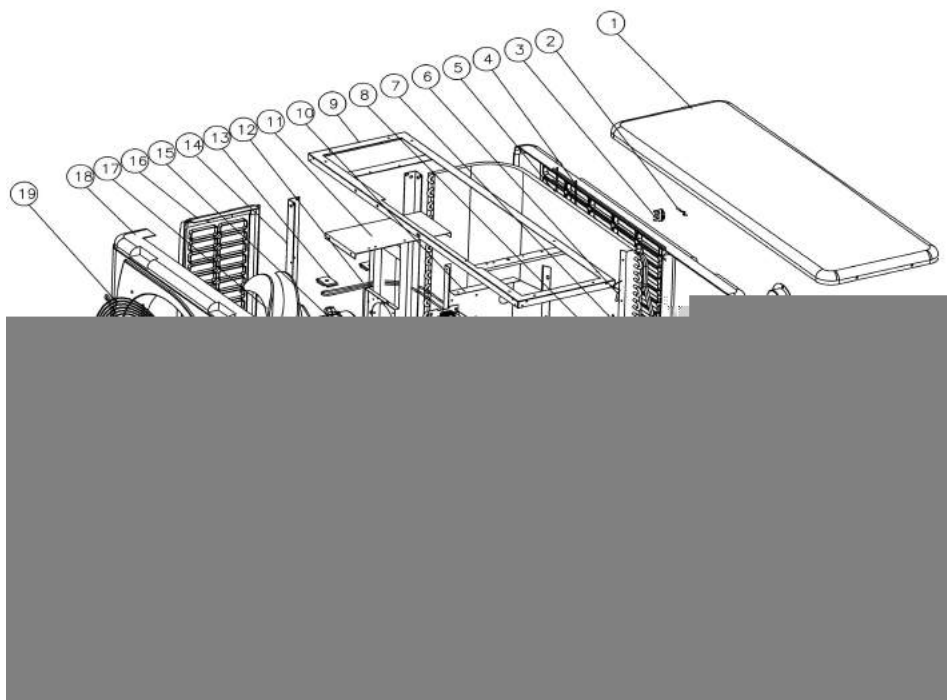

9.2 Distinta pezzi di ricambio

Modello : 71676

NO	ERP	Denominazione pezzi	NO	ERP	Denominazione pezzi
1	1330900291	Coperchio superiore	34	117020180	Controller
2	117110020	Sonda temp. ambiente T5-TH1	35	103000227	Tubi evaporatore
3	133020010	Clip sonda temp. ambiente	36	136020018	Bloccogomma
4	1330900271	Pannello posteriore	37	103000227	Tubi di distribuzione
5	103000227	Evaporatore	38	106000011	Manometro
6	117110004	Sonda evaporatore T3-TH2	39	113020320	Tubi di ritorno gas
7	113190001	Sede sonda	40	113080074	EEV per tubi di distribuzione
8	113190001	Clip	41	113070042	Scambiatore per EEV
9	108110038	Telaio superiore	42	119000017	EEV
10	108050073	Pannello isolante	43	116000071	Mini-pressostato di bassa pressione
11	108110043	Supporto motoventilatore	44	117110021	Sonda di temperatura scarico T6-TH3
12	142000058	Resistenza riscaldamento evaporatore	45	113010229	Tubo di scarico
13	108480015	Fissaggio resistenza evaporatore	46	113030081	Valvola a 4 vie per scambiatore
14	108110004	Colonna	47	116000066	Mini-pressostato di altra pressione
15	112000031	Motoventilatore	48	113060123	Tubo
16	1330900261	Pannello laterale sinistro	49	121000006	Valvola a 4 vie
17	132000015	Pala del ventilatore	50	150000110	Tappo di drenaggio
18	1330900251	Pannello frontale	51	117110012	Sonda temperatura acqua entrata T1-TH6
19	108010014	Griglia ventilatore	52	108010025	Clip sonda di temperatura dello scambiatore
20	117230003	Reattore	53	102040705	Scambiatore di calore in titanio
21	101000187	Compressore + basi anti-vibrazioni	54	133020026	Guarnizione di gomma su collegamento per l'acqua
22	142000072	Resistenza riscaldamento compressore	55	133020011	Anello gomma blu
23	101000187	Compressore + basi anti-vibrazioni	56	113900082	Set collegamento dell'acqua
24	113100008	Piastra fissaggio valvola a globo	57	133020011	Guarnizione di gomma rossa
25	120000091	Valvola a globo	58	117110011	Sonda temperatura acqua in uscita T2-TH5
26	180140064	Vaschetta base	59	116000001	Guarnizione di tenuta flussostato acqua
27	108010065	Piastra morsetti di connessione	60	112100021-1	Flussostato dell'acqua
28	115000004	Morsetti di connessione	61	117010095	Modulo Modbus
29	113100009	Clip per cavo di connessione	62	117240002	Anello magnetico
30	1330900281	Pannello destro	63	108110057	Scatola elettrica
31	1332500051	Coperchio in plastica della scatola di connessione	64	117240003	Anello magnetico
32	108010018	Scatola del controller	65	117100046	PCB
33	113712007	Scatola impermeabile del controller	66	108050017	Coperchio scatola elettrica

9.3 Modello: 71677/71678/71679

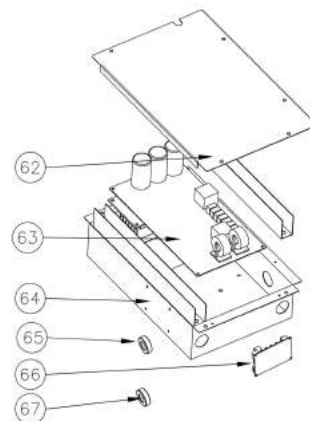
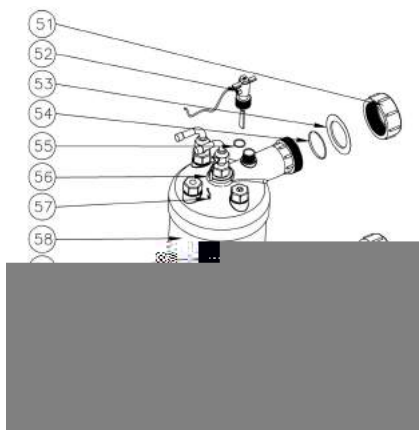
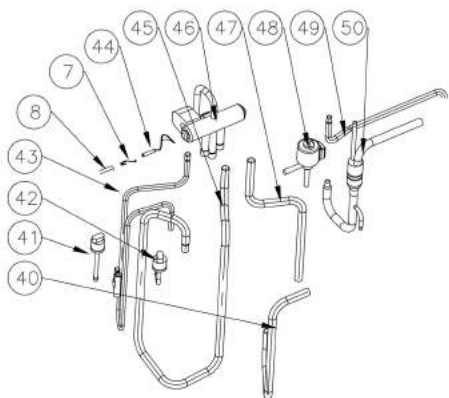
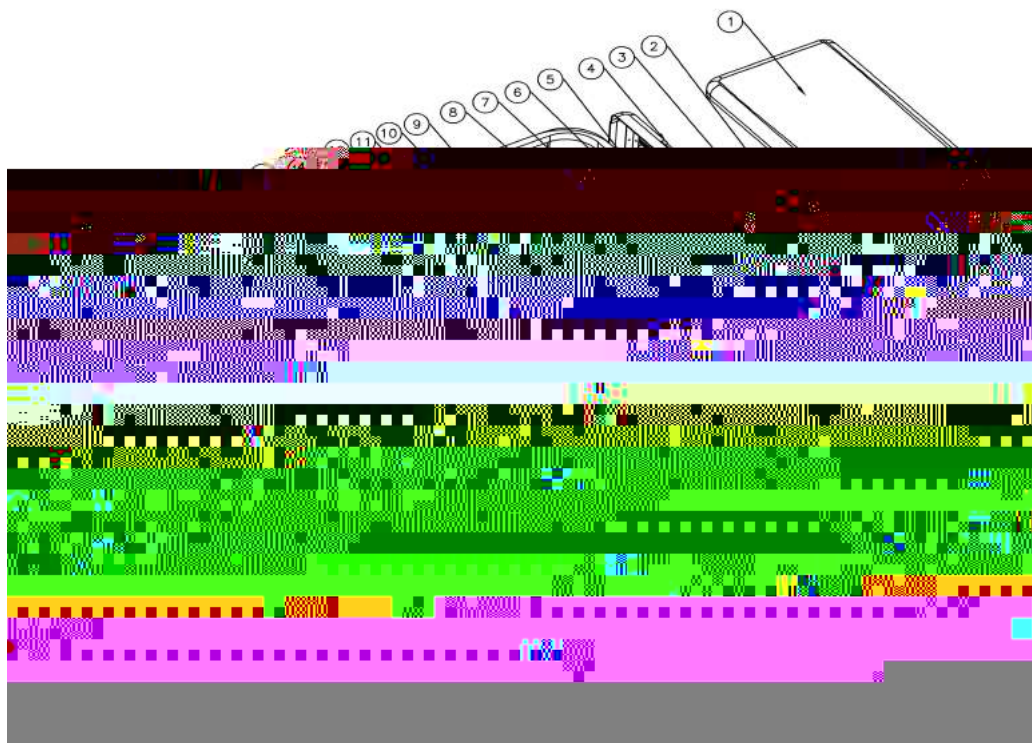

9.4 Distinta pezzi di ricambio: 71677

NO	ERP	Denominazione pezzi	NO	ERP	Denominazione pezzi
1	1330900291	Coperchio superiore	35	113712007	Scatola impermeabile del controller
2	117110020	Sonda temp. ambiente T5-TH1	36	117020180	Controller
3	133020010	Clip sonda temp. ambiente	37	103000221	Tubi evaporatore
4	1330900271	Pannello posteriore	38	136020005	Blocco in gomma
5	103000221	Evaporatore	39	103000221	Tubi di distribuzione
6	117110004	Sonda evaporatore T3-TH2	40	113030086	Valvola a 4 vie per scambiatore
7	113100009	Clip	41	116000066	Mini-pressostato di altra pressione
8	113100009	Sede sonda	42	116000071	Mini-pressostato di bassa pressione
9	108110038	Telaio superiore	43	113010210	Tubo di scarico
10	108110043	Supporto motoventilatore	44	117110021	Sonda di temp scarico T6-TH3
11	117230003	Reattore	45	113020322	Tubi di ritorno del gas
12	108480015	Fissaggio resistenza evaporatore	46	121000006	Valvola a 4 vie
13	108110004	Colonna	47	113060084	Valvola a 4 vie per collettori
14	142000079	Resistenza riscaldamento dell'evaporatore	48	119000017	EEV
15	112000031	Motoventilatore	49	113080054	EEV per tubi di distribuzione
16	1330900261	Pannello laterale sinistro	50	113070044	Scambiatore per EEV
17	108010024	Coperchio asse ventilatore	51	113900082	Set di collegamento dell'acqua
18	132000015	Pala del ventilatore	52	112100021-1	Flussostato dell'acqua
19	1330900251	Pannello frontale	53	133020012	Guarnizione in gomma rosso
20	108010014	Griglia ventilatore	54	133020026	Guarnizione di gomma su collegamento per l'acqua
21	108050073	Pannello isolante	55	136020083	Guarnizione di tenuta flussostato acqua
22	113100008	Tubo di rame	56	117110011	Sonda temperatura acqua in uscita T2-TH5
23	120000091	Valvola a globo	57	108010025	Clip sonda di temperatura dello scambiatore
24	142000074	Resistenza riscaldamento del compressore	58	102040748	Scambiatore di calore in titanio
25	101000188	Compressore + basi anti-vibrazioni	59	133020011	Guarnizione in gomma blu
26	101000188	Compressore + basi anti-vibrazioni	60	117110012	Sonda temperatura acqua in entrata T1-TH6
27	108110066	Vaschetta base	61	150000110	Tappo di drenaggio
28	108010065	Piastra connessione morsetti	62	108050017	Coperchio scatola elettrica
29	133090028	Pannello destro	63	117100046	PCB
30	106000011	Manometro	64	108110031	Scatola elettrica
31	136010004	Clip per cavi di connessione	65	117240002	Anello magnetico
32	115000004	Morsetto di connessione	66	117010095	Modulo Modbus
33	1332500051	Coperchio in plastica scatola di connessione	67	117240003	Anello magnetico
34	133030011	Scatola del controller			

9.5 Distinta pezzi di ricambio: 71678

NO	ERP	Denominazione pezzi	NO	ERP	Denominazione pezzi
1	1330900291	Coperchio superiore	34	133030011	Scatola del controller
2	117110020	Sonda temp. ambiente T5-TH1	35	113712007	Scatola impermeabile del controller
3	133020010	Clip sonda temp. ambiente	36	117020180	Controller
4	1330900271	Pannello posteriore	37	103000182	Tubi evaporatore
5	103000182	Evaporatore	38	136020005	Blocco di gomma
6	117110004	Sonda evaporatore T3-TH2	39	103000182	Tubi di distribuzione
7	113100009	Sede sonda	40	113030086	Valvola a 4 vie per scambiatore
8	113100009	Clip	41	116000066	Mini-pressostato di altra pressione
9	108110038	Telaio superiore	42	116000071	Mini-pressostato di bassa pressione
10	108110043	Supporto motoventilatore	43	113010210	Tubo di scarico
11	117230003	Reattore	44	117110021	Sonda di temp scarico T6-TH3
12	108480015	Fissaggio resistenza evaporatore evaporatore	45	113020322	Tubo di ritorno del gas
13	108110004	Colonna	46	121000006	Valvola a 4 vie
14	142000079	Resistenza riscaldamento dell'evaporatore	47	113060084	Valvola a 4 vie per collettori
15	112000031	Motoventilatore	48	119000017	EEV
16	1330900261	Pannello laterale sinistro	49	113080054	EEV per tubi di distribuzione
17	108010024	Coperchio asse ventilatore	50	113070044	Scambiatore per EEV
18	132000015	Pala del ventilatore	51	113900082	Set di collegamento dell'acqua
19	133090025	Pannello frontale	52	112100021-1	Flussostato dell'acqua
20	108010014	Griglia ventilatore	53	133020011	Guarnizione di gomma rossa
21	108050073	Pannello isolante	54	133020026	Guarnizione di gomma su collegamento per l'acqua
22	113100008	Tubo di rame	55	116000001	Guarnizione di tenuta flussostato acqua
23	120000091	Valvola a globo	56	117110011	Sonda temperatura acqua in uscita T2-TH5
24	142000074	Resistenza riscaldamento del compressore	57	117110012	Clip sonda temperatura scambiatore
25	101000188	Compressore + basi anti-vibrazioni	58	102040708	Scambiatore di calore in titanio
26	101000188	Compressore + basi anti-vibrazioni	59	133020011	Guarnizione in gomma blu
27	108110066	Vaschetta base	60	117110012	Sonda temperatura acqua in entrata T1-TH6
28	108010065	Piastra connessione morsetti	61	150000110	Tappo di drenaggio
29	1330900281	Pannello destro	62	108050017	Coperchio scatola elettrica
30	106000011	Manometro	63	117100047	PCB
31	136010004	Clip per cavi di connessione	64	108110057	Scatola elettrica
32	115000004	Morsetto di connessione	65	117240002	Anello magnetico
33	1332500051	Coperchio in plastica scatola di connessione	66	117010095	Modulo Modbus
			67	117240003	Anello magnetico

9.6 Distinta pezzi di ricambio: 71679

NO	ERP	Denominazione pezzi	NO	ERP	Denominazione pezzi
1	1330900291	Coperchio superiore	35	113712007	Scatola impermeabile del controller
2	117110020	Sonda temp. ambiente T5-TH1	36	117020180	Controller
3	133020010	Clip sonda temp. ambiente	37	10	

9.7 Modello: 71680/71681

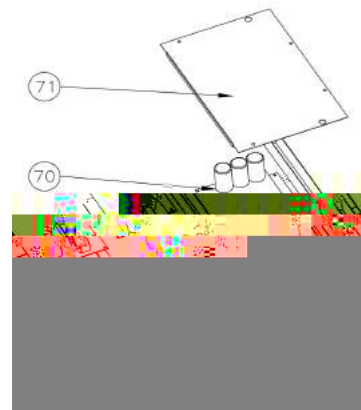
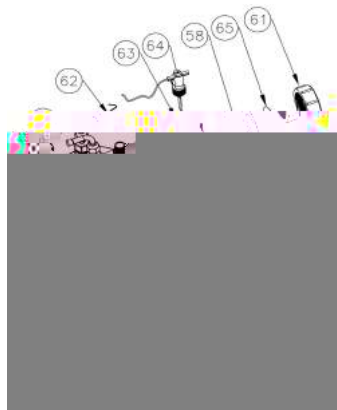
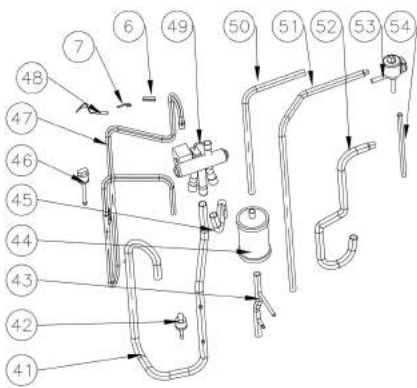
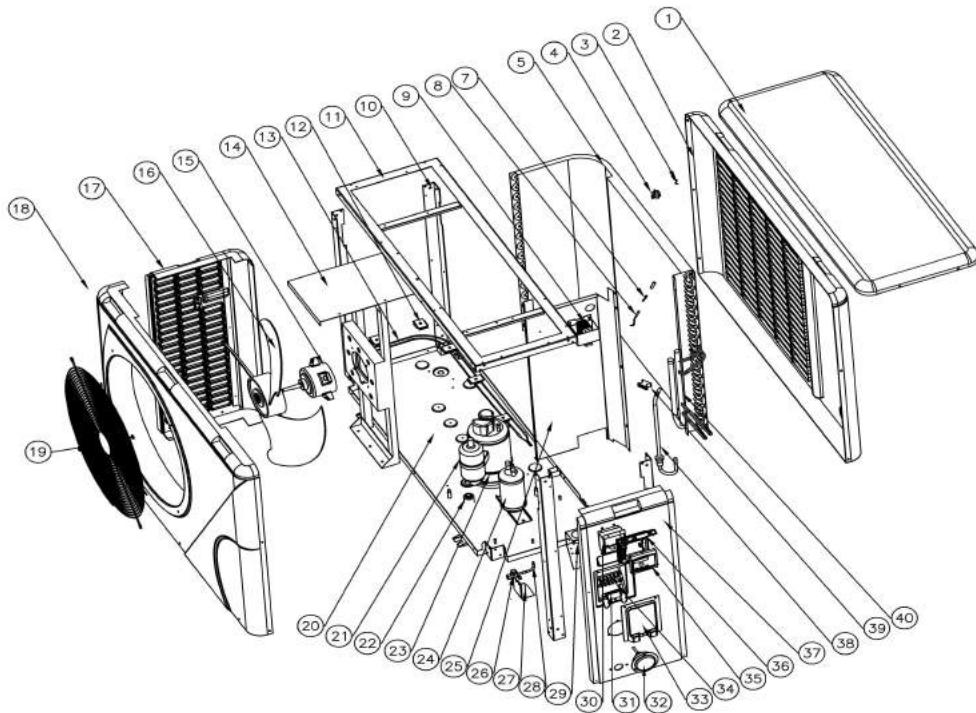

9.8 Distinta pezzi di ricambio: 71680

NO	ERP	Denominazione pezzi	NO	ERP	Denominazione pezzi
1	1332600011	Coperchio superiore	37	1332600041	Pannello destro
2	1332600021	Pannello posteriore	38	103000230	Tubi di distribu

9.9 Distinta pezzi di ricambio: 71681

NO	ERP	Denominazione pezzi	NO	ERP	Denominazione pezzi
1	1332600011	Coperchio superiore	37	1332600041	Pannello destro
2	1332600021	Pannello posteriore	38	103000204	Tubi di distribuzione
3	117110020	Sonda temp. ambiente T5-TH1	39	136020005	Blocco di gomma
4	133020010	Clip sonda temp. ambiente	40	103000204	Tubi evaporatore
5	103000204	Evaporatore	41	113020339	Tubi di ritorno del gas
6	113100009	Sede sonda	42	116000073	Mini-pressostato di bassa pressione
7	113100009	Clip	43	113130021	Tubi per filtro disidratatore
8	117110004	Sonda evaporatore T3-TH2	44	120000066	Filtro disidratatore
9	117230002	Reattore	45	113060096	Valvola a 4 vie per tubi collettori
10	108560003	Colonna	46	116000068	Mini-pressostato di altra pressione
11	108560002	Telaio superiore	47	113010245	Tubo di scarico
12	108480015	Fissaggio resistenza evaporatore	48	117110021	Sonda di temp scarico T6-TH3
13	142000144	Resistenza riscaldamento dell'evaporatore	49	121000009	Valvola a 4 vie
14	108560011	Supporto motoventilatore	50	113170032	Tubi filtro disidratatore
15	112000031	Motoventilatore	51	113120019	Tubi di rame per evaporatore
16	132000023	Pala del ventilatore	52	113030093	Valvola a 4 vie per scambiatore
17	1332600051	Pannello laterale sinistro	53	119000021	EEV
18	1332600031	Pannello frontale	54	113080056	EEV per tubi di distribuzione
19	108170017	Griglia ventilatore	55	150000110	Tappo di drenaggio
20	108560036	Vaschetta base	56	108010025	Clip sonda temperatura scambiatore
21	101000185	Compressore + basi anti-vibrazioni	57	117110012	Sonda temperatura acqua in entrata T1-TH6
22	101000185	Compressore + basi anti-vibrazioni	58	133020026	Guarnizione di gomma su collegamento per l'acqua
23	142000077	Resistenza riscaldamento del compressore	59	133020011	Guarnizione di gomma blu
24	105000004	Serbatoio liquido	60	102040764	Scambiatore di calore in titanio
25	108560010	Pannello isolante	61	113900082	Set di collegamento dell'acqua
26	120000091	Valvola a globo	62	117110011	Sonda temperatura acqua in uscita T2-TH5
27	108560034	Supporto valvola a globo	63	136020083	Guarnizione di tenuta flussostato
28	113100008	Tubo di rame	64	112100021-1	Flussostato dell'acqua
29	108010065	Piastra morsetti di connessione	65	133020012	Guarnizione di gomma rossa
30	133030011	Scatola del controller	66	117010095	Modulo Modbus
31	136010004	Clip per cavo di connessione	67	117240002	Anello magnetico
32	106000011	Manometro	68	117240003	Anello magnetico
33	1332500051	Coperchio in plastica scatola di connessione	69	108560012	Scatola elettrica
34	115000004	Morsetto di connessione	70	117100048	PCB
35	117020180	Controller	71	108540006	Coperchio scatola elettrica
36	113712007	Scatola impermeabile del controller			

9.10 Modello: 71682,71683

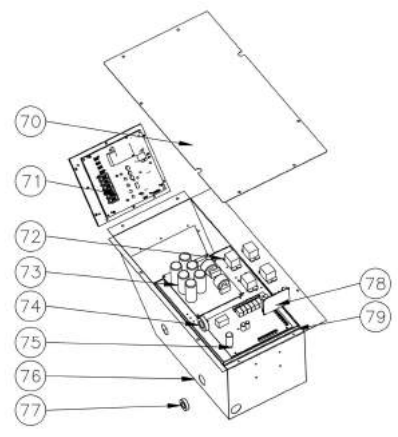
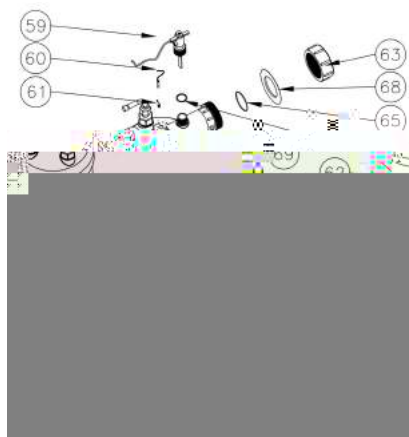
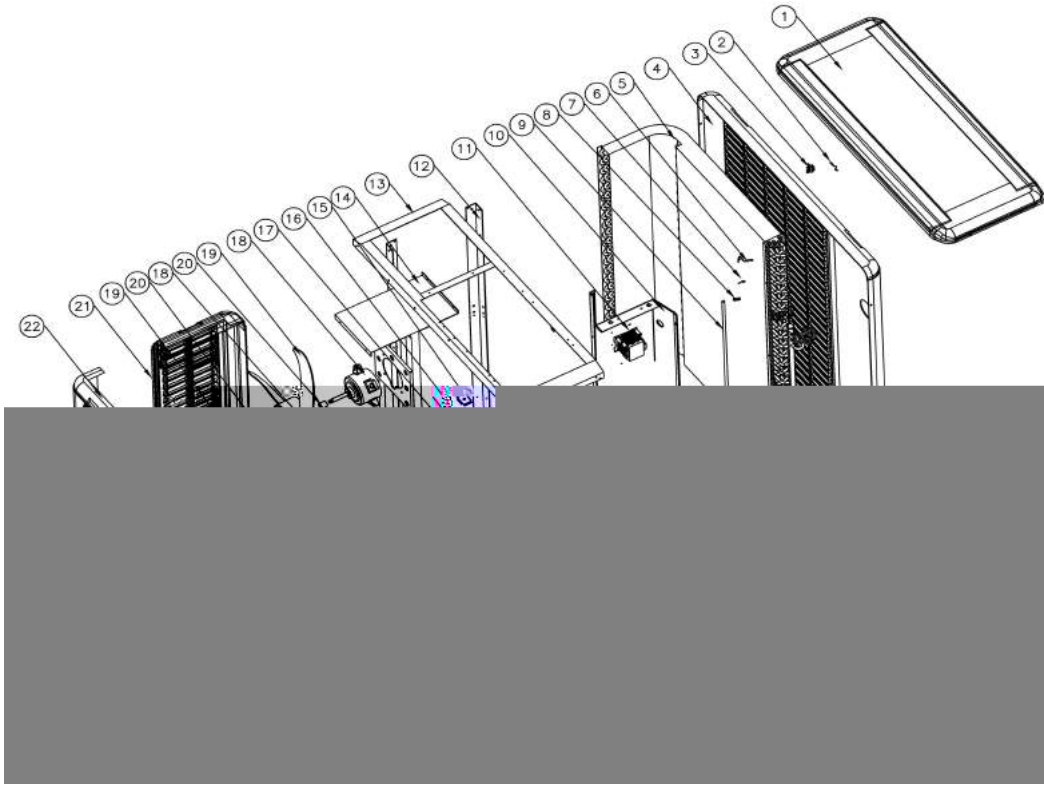

7	113100009	Clip	48	113010227	Tubo di scarico
8	113100009	Sede sonda	49	113030087	Valvola a 4 vie per scambiatore
9	103000208	Tubi di distribuzione	50	121000009	Valvola a 4 vie
10	108120036	Pannello isolante	51	116000008	Mini-pressostato di altra pressione
11	117230001	Reattore	52	117110021	Sonda di temp di scarico T6-TH3
12	108120035	Colonna	53	113120020	Tubi di rame per evaporatore
13	108120034	Telaio superiore	54	113130005	Reattore per filtro disidratatore
14	1120044	Supporto motoventilatore	55	113000035	EEV per tubi di distribuzione
15	100000015	Fissaggio resistenza evaporatore	56	119000021	EEV
16	142000079	Resistenza riscaldamento dell'evaporatore	57	120000036	Filtro disidratatore
17	100000009	Colonna	58	113170005	Centro disidratatore
18	100000031	Motoventilatore	59	112100021-1	Flussostato del flusso dell'acqua
19	132000015	Pala del ventilatore	60	117110011	Sonda temperatura acqua in uscita T2-TH5
20	108010024	Coperchio asse ventilatore	61	108010025	Clip sonda di temperatura dello scambiatore
21	133250004	Pannello laterale sinistro			

9.12 Distinta pezzi di ricambio: 71683

NO	ERP	Denominazione pezzi	NO	ERP	Denominazione pezzi
1	133100001	Coperchio superiore	41	117020180	Controller
2	117110020	Sonda temp. ambiente T5-TH1	42	113712007	Scatola impermeabile controller
3	133020010	Clip sonda temp. ambiente	43	103000209	Tubi evaporatore
4	133250003	Pannello posteriore	44	136020005	Blocco di gomma
5	103000209	Evaporatore	45	113020389	Tubi di ritorno gas
6	117110004	Sonda evaporatore T3-TH2	46	116000073	Mini-pressostato di bassa pressione
7	113100009	Clip	47	113060083	Valvola a 4 vie per collettori
8	113100009	Sede sonda	48	113010228	Tubo di scarico
9	103000209	Tubi di distribuzione	49	113030087	Valvola a 4 vie per scambiatore
10	108120036	Pannello isolante	50	121000009	Valvola a 4 vie
11	117230001	Reattore	51	116000008	Mini-pressostato di altra pressione
12	108120035	Colonna	52	117110021	Sonda di temp di scarico T6-TH3
13	108120034	Telaio superiore	53	113120020	Tubi di rame per evaporatore
14	108120044	Supporto motoventilatore	54	113130020	Tubi per filtro disidratatore
15	108480015	Fissaggio resistenza evaporatore	55	113080055	EEV per tubi di distribuzione
16	142000079	Resistenza riscaldamento dell'evaporatore	56	119000042	EEV
17	108550009	Colonna	57	120000066	Filtro disidratatore
18	112000031	Motoventilatore	58	113170028	Tubi filtro disidratatore
19	132000015	Pala del ventilatore	59	112100021-1	Flussostato del flusso dell'acqua
20	108010024	Coperchio asse ventilatore	60	117110011	Sonda temperatura acqua in uscita T2-TH5
21	133250004	Pannello laterale sinistro	61	108010025	Clip sonda di temperatura dello scambiatore
22	133250001	Pannello frontale	62	102040754	Scambiatore di calore in titanio
23	108010014	Griglia ventilatore	63	113900082	Set di collegamento dell'acqua
24	120000091	Valvola a globo	64	133020012	Guarnizione di gomma blu
25	113100008	Tubo di rame	65	133020026	Guarnizione di gomma su collegamento per l'acqua
26	101000186	Compressore + basi anti-vibrazioni	66	117110012	Sonda temperatura acqua in entrata T1-TH6
27	101000186	Compressore + basi anti-vibrazioni	67	150000110	Tappo di drenaggio
28	105000008	Serbatoio liquido	68	133020011	Guarnizione di gomma rossa
29	142000077	Resistenza riscaldamento del	69	136020083	Guarnizione di tenuta flussostato
30	108470069	Vaschetta base	70	108120040	Coperchio scatola elettrica
31	108550008	Tenditore piastra	71	117140016	PCB Controllo principale
32	108010065	Piastra morsetti di connessione	72	142000038	Relè
33	133250002	Pannello destro	73	117260001	Scheda filtri
34	115000025	Morsetti di connessione	74	117240002	Anello magnetico
35	106000011	Manometro	75	117250007	PCB
36	136010004	Clip per cavo di connessione	76	108120038	Scatola filtri
37	108550006	Supporto morsetti	77	117240003	Anello magnetico
38	115000027	Morsetto di connessione impianto filtrante	78	117010095	Modulo Modbus
39	133250005	Coperchio in plastica scatola di connessione	79	108120039	Quadro elettrico
40	133030011	Scatola			

9.13 Modello: 68821/68822/68823

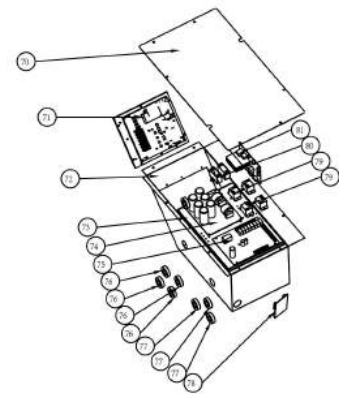
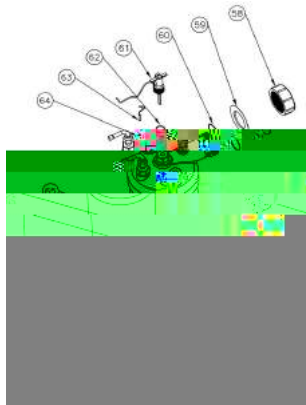
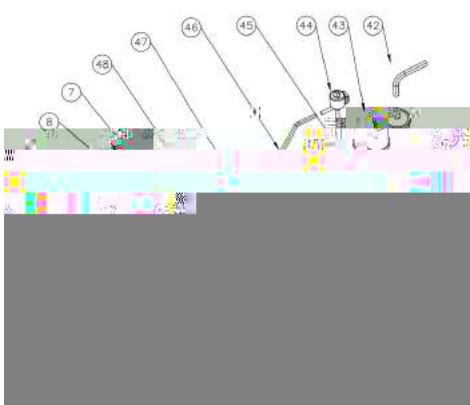
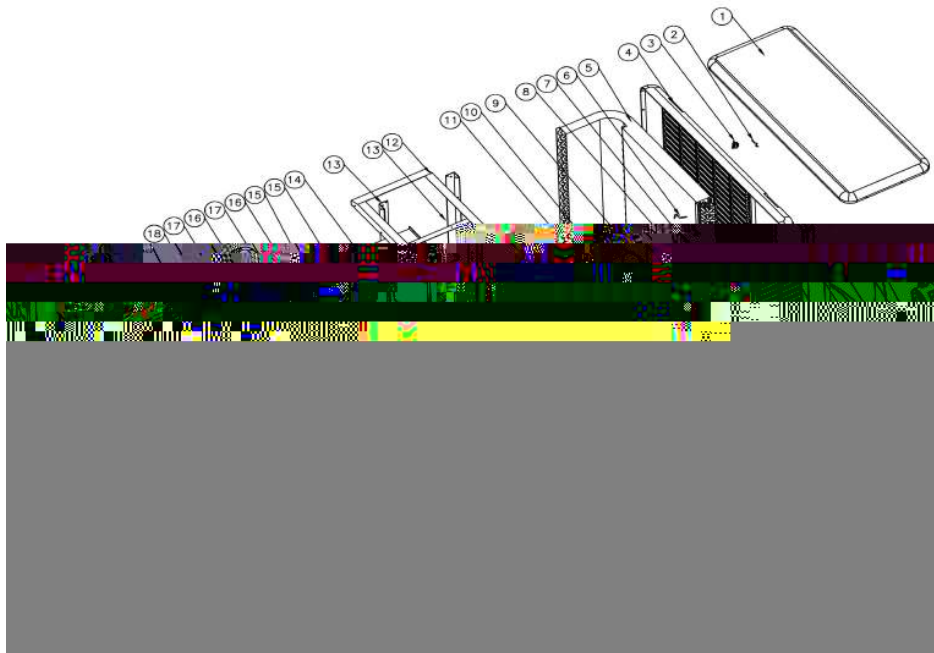

9.14 Distinta pezzi di ricambio: 68821

NO	ERP	Denominazione pezzi	NO	ERP	Denominazione pezzi
1	133100001	Coperchio superiore	41	113050109	Collettori
2	117110020	Sonda temp. ambiente T5-TH1	42	113170028	Tubi filtro disidratatore
3	133020010	Clip sonda temp. Ambiente	43	120000066	Filtro disidratatore
4	133250003	Pannello posteriore	44	119000022	EEV
5	103000153	Evaporatore	45	113080055	EEV per tubi di distribuzione
6	117110004	Sonda evaporatore T3-TH2	46	113120020	Tubi di rame per evaporatore
7	113190001	Clip	47	113030087	Valvola a 4 vie per scambiatore
8	113190001	Sede sonda	48	117110021	Sonda di temp scarico T6-TH3
9	113040101	Tubi di distribuzione	49	116000008	Mini-pressostato di altra pressione
10	108550010	Pannello isolante	50	121000009	Valvola a 4 vie
11	117230002	Reattore	51	120000023	Valvola di aspirazione
12	108120034	Telaio superiore	52	113010158	Tubo di scarico
13	108120035	Colonna	53	116000080	Mini-pressostato di bassa pressione 0.2-0.35
14	108120037	Supporto motoventilatore	54	116000079	Mini-pressostato di bassa pressione 0.1-0.3
15	112000031	Motoventilatore	55	113020245	Tubi di ritorno gas
16	108010024	Coperchio asse ventilatore	56	113060083	Valvola a 4 vie per collettori
17	132000015	Pala del ventilatore	57	113130015	Tubi per filtro disidratatore
18	133250004	Pannello laterale sinistro	58	113900082	Set di collegamento dell'acqua
19	133250001	Pannello frontale	59	133020011	Guarnizione di gomma rossa
20	108010014	Griglia ventilatore	60	133020026	Guarnizione di gomma su collegamento per l'acqua
21	108550009	Colonna	61	112100021-1	Flussostato dell'acqua
22	108550005	Vaschetta base	62	116000001-2	Guarnizione di tenuta flussostato
23	101000149	Compressore	63	117110011	Sonda temperatura acqua in uscita T2-TH5
24	105000008	Serbatoio liquido	64	108010025	Clip sonda di temperatura scambiatore
25	142000077	Resistenza riscaldamento del compressore	65	113900082	Set collegamento dell'acqua
26	101000149	Compressore + basi anti-vibrazioni	66	133020012	Guarnizione di gomma blu
27	108550008	Tenditore piastra	67	102040503	Scambiatore di calore in titanio
28	108010065	Piastra connessione morsetti	68	117110012	Sonda temperatura acqua in entrata T1-TH6
29	110000008	Guarnizione di gomma	69	150000110	Tappo di drenaggio
30	108010018	Scatola del controller	70	108120040	Coperchio scatola elettrica
31	133250002	Pannello destro	71	117140003	PCB controllo principale
32	115000025	Morsetto di connessione	72	108120038	Scatola elettrica
33	110800001	Manometro	73	108120039	Piastra supporto componenti elettrici
34	136010004	Clip per cavo di connessione	74	117260002	Piastra filtri
35	108550006	Colonna	75	117250001-V1.5	PCB
36	115000027	Morsetto conn. impianto filtrante	76	117240002	Anello magnetico
37	133250005	Coperchio in plastica scatola di connessione	77	117240003	Anello magnetico
38	113712007	Scatola impermeabile del	78	117010095	Modulo Modbus
39	117020150	Controller	79	142000038	Relè
40	136020005	Blocco di gomma	80	N/A	N/A
			81	117140006	Fan scheda di comando del motore

9.15 Distinta pezzi di ricambio: 68822

NO	ERP	Denominazione pezzi	NO	ERP	Denominazione pezzi
1	133100001	Coperchio superiore	41	113050110	Collettori
2	117110020	Sonda temp. ambiente T5-TH1	42	113170028	Tubi filtro disidratatore
3	133020010	Clip sonda temp. Ambiente	43	120000066	Filtro disidratatore
4	133250003	Pannello posteriore	44	119000022	EEV
5	103000154	Evaporatore	45	113080055	EEV per tubi di distribuzione
6	117110004	Sonda evaporatore T3-TH2	46	113120020	Tubi di rame per evaporatore
7	113190001	Clip	47	113030087	Valvola a 4 vie per scambiatore
8	113190001	Sede sonda	48	117110021	Sonda di temp scarico T6-TH3
9	113040102	Tubi di distribuzione	49	116000008	Mini-pressostato di altra pressione
10	108550010	Pannello isolante	50	121000009	Valvola a 4 vie
11	117230004	Reattore	51	120000023	Valvola di aspirazione
12	108120034	Telaio superiore	52	113010158	Tubo di scarico
13	108120035	Colonna	53	116000080	Mini-pressostato di bassa pressione 0.2-0.35
14	108120037	Supporto motoventilatore	54	116000079	Mini-pressostato di bassa pressione 0.1-0.3
15	112000031	Motoventilatore	55	113020245	Tubi di ritorno gas
16	108010024	Coperchio asse ventilatore	56	113060083	Valvola a 4 vie per collettori
17	132000015	Pala del ventilatore	57	113130015	Tubi per filtro disidratatore
18	133250004	Pannello laterale sinistro	58	113900082	Set di collegamento dell'acqua
19	133250001	Pannello frontale	59	133020011	Guarnizione di gomma rossa
20	108010014	Griglia ventilatore	60	133020026	Guarnizione di gomma su collegamento per l'acqua
21	108550009	Colonna	61	112100021-1	Flussostato dell'acqua
22	108550005	Vaschetta base	62	116000001-2	Guarnizione di tenuta flussostato
23	101000122	Compressore + basi anti-vibrazioni	63	117110011	Sonda temperatura acqua in uscita T2-TH5
24	105000008	Serbatoio liquido	64	108010025	Clip sonda di temperatura scambiatore
25	142000077	Resistenza riscaldamento del compressore	65	113900082	Set collegamento dell'acqua
26	101000122	Compressore + basi anti-vibrazioni	66	133020012	Guarnizione di gomma blu
27	108550008	Tenditore piastra	67	102040502	Scambiatore di calore in titanio
28	108010065	Piastra morsetto di connessione	68	117110012	Sonda temperatura acqua in entrata T1-TH6
29	110000008	Guarnizione di gomma	69	150000110	Tappo di drenaggio
30	108010018	Scatola del controller	70	108120040	Coperchio scatola elettrica
31	133250002	Pannello destro	71	117140002	PCB controllo principale
32	115000025	Morsetto di connessione	72	108120038	Scatola elettrica
33	110800001	Manometro	73	108120039	Piastra supporto componenti elettrici
34	136010004	Clip per cavo di connessione	74	117260001	Piastra filtri
35	108550006	Colonna	75	117250001-V1.5	PCB
36	115000027	Morsetto conn. impianto filtrante	76	117240002	Anello magnetico
37	133250005	Coperchio in plastica scatola di connessione	77	117240003	Anello magnetico
38	113712007	Scatola impermeabile del controller	78	117010095	Modulo Modbus
39	117020150	Controller	79	142000038	Relè
40	136020005	Blocco di gomma	80	N/A	N/A
			81	N/A	N/A

9.16 Distinta pezzi di ricambio: 68823

NO	ERP	Denominazione pezzi	NO	ERP	Denominazione pezzi
1	133100001	Coperchio superiore	41	113050110	Collettori
2	117110020	Sonda temp. ambiente T5-TH1	42	113170028	Tubi filtro disidratatore
3	133020010	Clip sonda temp. Ambiente	43	120000066	Filtro disidratatore
4	133250003	Pannello posteriore	44	119000022	EEV
5	103000154	Evaporatore	45	113080055	EEV per tubi di distribuzione
6	117110004	Sonda evaporatore T3-TH2	46	113120020	Tubi di rame per evaporatore
7	113190001	Clip	47	113030087	Valvola a 4 vie per scambiatore
8	113190001	Sede sonda	48	117110021	Sonda di temp scarico T6-TH3
9	113040102	Tubi di distribuzione	49	116000008	Mini-pressostato di altra pressione
10	108550010	Pannello isolante	50	121000009	Valvola a 4 vie
11	117230002	Reattore	51	120000023	Valvola di aspirazione
12	108120034	Telaio superiore	52	113010158	Tube di scarico
13	108120035	Colonna	53	116000080	Mini-pressostato di bassa pressione 0.2-0.35
14	108120037	Supporto motoventilatore	54	116000079	Mini-pressostato di bassa pressione 0.1-0.3
15	112000031	Motoventilatore	55	113020245	Tubi di ritorno gas
16	108010024	Coperchio asse ventilatore	56	113060083	Valvola a 4 vie per collettori
17	132000015	Pala del ventilatore	57	113130015	Tubi per filtro disidratatore
18	133250004	Pannello laterale sinistro	58	113900082	Set di collegamento dell'acqua
19	133250001	Pannello frontale	59	133020011	Guarnizione di gomma rossa
20	108010014	Griglia ventilatore	60	133020026	Guarnizione di gomma su collegamento per l'acqua
21	108550009	Colonna	61	112100021-1	Flussostato dell'acqua
22	108550005	Vaschetta base	62	116000001-2	Guarnizione di tenuta flussostato
23	101000149	Compressore + basi anti-vibrazioni	63	117110011	Sonda temperatura acqua in uscita T2-TH5
24	105000008	Serbatoio liquido	64	108010025	Clip sonda di temperatura scambiatore
25	142000077	Resistenza riscaldamento del compressore	65	113900082	Set collegamento dell'acqua
26	101000149	Compressore + basi anti-vibrazioni	66	133020012	Guarnizione di gomma blu
27	108550008	Tenditore piastra	67	102040502	Scambiatore di calore in titanio
28	108010065	Piastra morsetto di connessione	68	117110012	Sonda temperatura acqua in entrata T1-TH6
29	110000008	Guarnizione di gomma	69	150000110	Tappo di drenaggio
30	108010018	Scatola del controller	70	108120040	Coperchio scatola elettrica
31	133250002	Pannello destro	71	117140003	PCB controllo principale
32	115000006	Morsetto di connessione	72	108120038	Scatola elettrica
33	110800001	Manometro	73	108120039	Piastra supporto componenti elettrici
34	136010004	Clip per cavo di connessione	74	117260002	Piastra filtri
35	108550006	Colonna	75	117250001-V1.5	PCB
36	115000027	Morsetto conn. impianto filtrante	76	117240002	Anello magnetico
37	133250005	Coperchio di plastica scatola di connessione	77	117240003	Anello magnetico
38	113712007	Scatola impermeabile del controller	78	117010095	Modulo Modbus
39	117020150	Controller	79	142000038	Relè
40	136020005	Blocco di gomma	80	N/A	N/A
			81	117140006	Fan scheda di comando del motore

9.17 Manutenzione

- (1) Controllare con regolarità il sistema di erogazione dell'acqua per evitare che entri aria nel sistema con una conseguente riduzione della portata dell'acqua, Tali guasti comprometterebbero la performance e l'affidabilità della pompa di calore.
- (2) Pulire con regolarità le piscine e i sistemi filtranti per evitare di causare danni all'unità dovuti alla sporcizia presente nell'impianto di filtrazione.
- (3) Conservare la pompa di calore sempre asciutta, ben ventilata e pulita sul lato dello scambiatore di calore in modo tale da consentire uno scambio di calore senza problemi e un buon risparmio energetico.
- (4) Solo un tecnico qualificato è autorizzato a intervenire sulla pressione del sistema di refrigerazione.
- (5) Verificare la connessione del cavo di potenza. Se la pompa di calore inizia a funzionare in maniera anomala, spegnerla e contattare un tecnico qualificato.
- (6) Svuotare sempre l'acqua presente nella pompa di calore quando la medesima rimane ferma, ovvero in inverno o quando la temperatura ambiente scende sotto lo 0°C. Altrimenti, si corre il rischio di congelamento nello scambiatore in titanio con un conseguente annullamento della garanzia.
- (7) Si prega di riempire il gas R32 attraverso la valvola Globe all'interno della macchina..



BOMBA DE CALOR DE PISCINA

PRO ELYO INVERBOOST NN

1. Descrição
2. Informação de transporte
3. Especificações
4. Acessórios
5. Instalação e conexão
6. Cablagem eléctrica
7. Arranque da bomba de calor
8. Resolução de problemas
9. Diagrama Explodido e manutenção

Obrigado por utilizar a bomba de calor Pro Elyo Inverboost NN para a sua piscina, esta aquecerá a água da sua piscina e manterá a temperatura constante, quando a temperatura ambiente do ar estiver compreendida entre -20 e 50 °C.



ATENÇÃO: Este manual inclui todas as informações necessárias para a utilização e instalação da sua bomba de calor.

- * O instalador deve ler o manual e seguir atentamente as instruções de implementação e manutenção.
- * O instalador é responsável pela instalação do produto e deve seguir todas as instruções do fabricante e os regulamentos em aplicação. A instalação incorrecta em desacordo com o manual implica a exclusão da totalidade da garantia.
- * O fabricante declina qualquer responsabilidade pelos danos causados a pessoas, objectos e erros devidos à instalação que desobedeça à orientação deste manual. Qualquer utilização que não esteja em conformidade na origem da sua fabricação será considerada como perigosa.



AVISO:

*Por favor, esvazie sempre a água na bomba de calor durante o inverno ou quando a temperatura ambiente cair abaixo de 0 °C, de outro modo, o permutador de titânio sofrerá danos devido ao congelamento; o que implicará a perda de garantia.

*Por favor, desligue sempre a alimentação eléctrica, se pretender aceder ao interior da bomba de calor, devido à presença de alta voltagem no seu interior.

*Por favor, mantenha o controlador em lugar seco ou feche sempre bem a tampa de isolamento, para evitar danos no controlador provocados pela presença de humidade.

Notícia importante:

- Por favor, mantenha sempre a bomba de calor num local com ventilação e longe de qualquer objecto que possa provocar incêndio.
- Não efectue soldaduras nos tubos se existir refrigerante dentro da máquina. Por favor, mantenha a máquina fora do espaço confinado quando fizer o enchimento de gás.
- O tubo deve ser aspirado antes de encher o gás R32 da válvula no interior da máquina.

1.1 Com a sua bomba de calor:

- Conjunto de conexão de água 50 mm (unid. 2)
- Manual do utilizador e serviço
- Conexão condensados
- Cabo de sinal com 10 metros
- Caixa impermeável
- Capa de inverno
- Base anti vibração (peças: 4)

1.2 Dimensão

Modelos: 71676

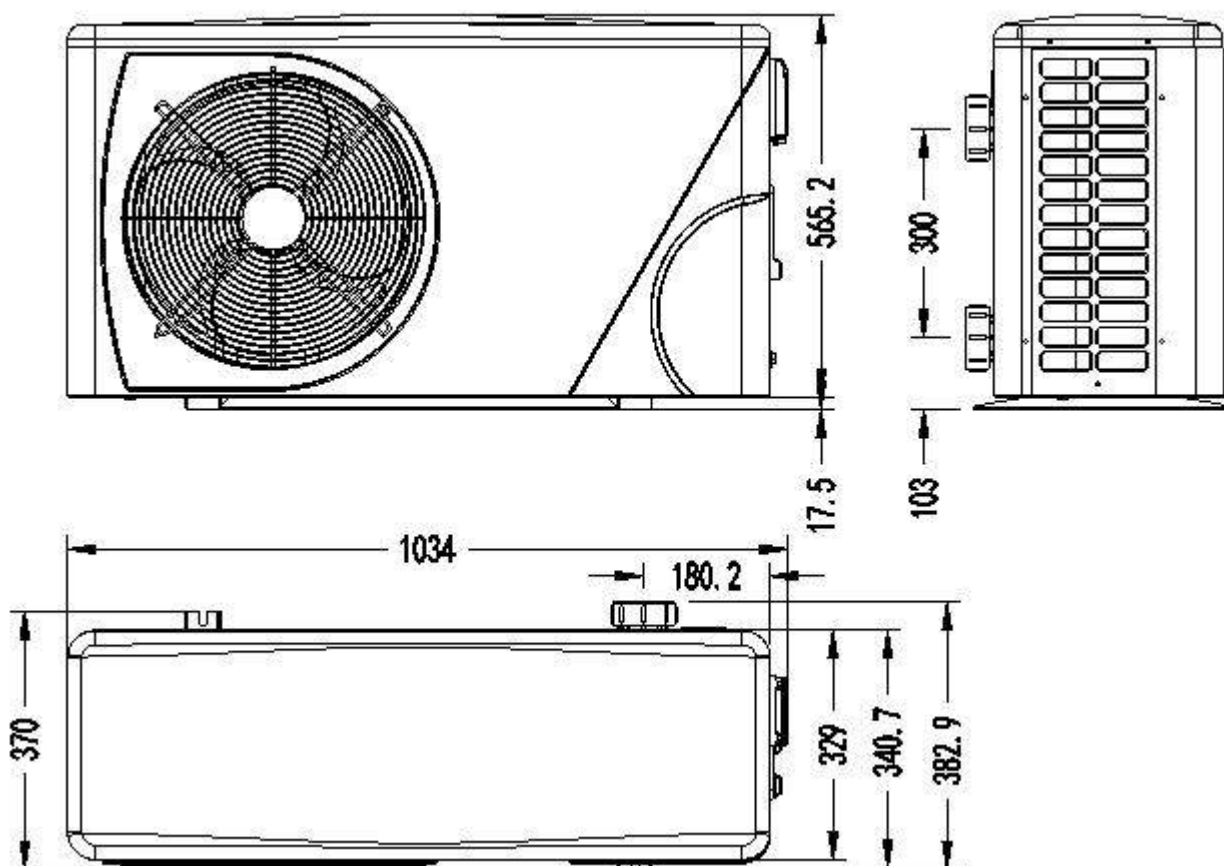

Modelos: 71677/71678/71679

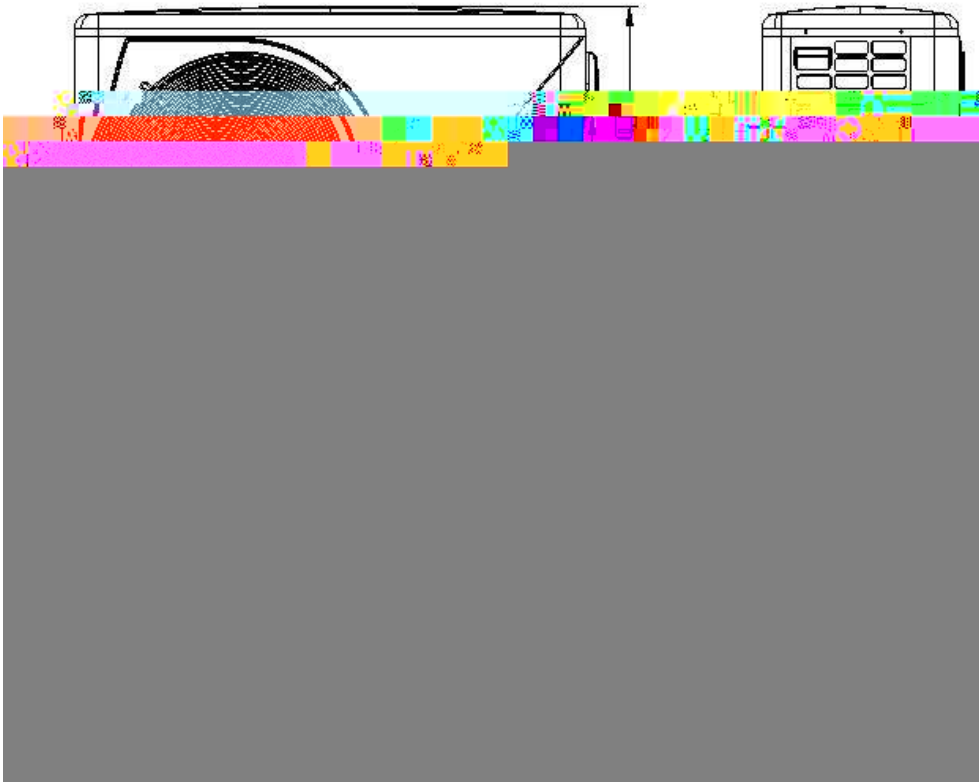

Models: 71680/71681

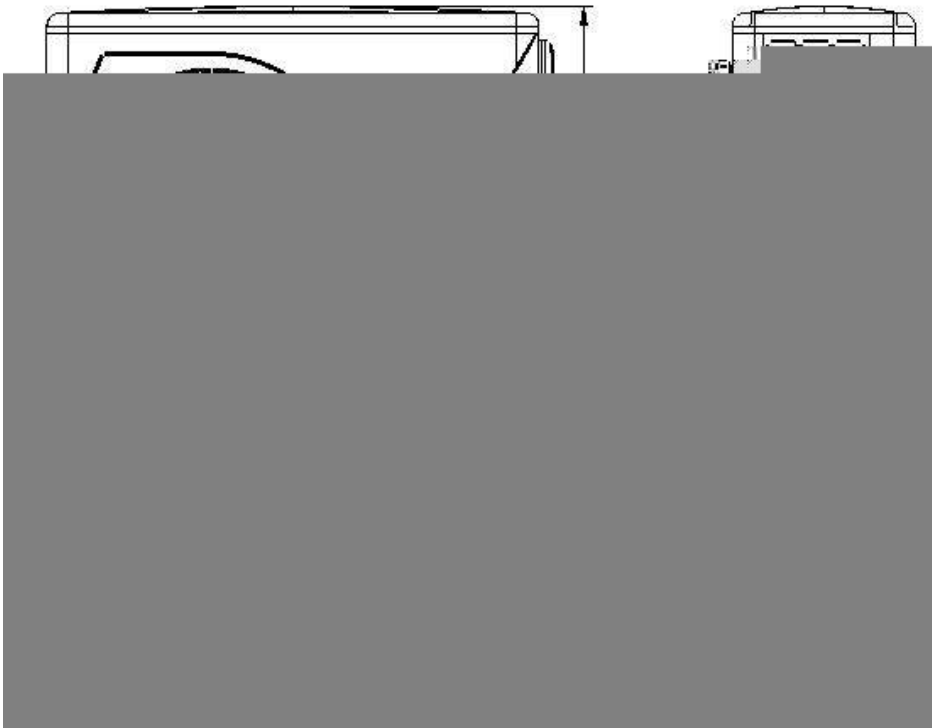

Modelos: 71682/71683/68821/68822/68823





...e cobertas com uma caixa de cartão. ... transportada na sua embalagem de ori... cedor, pode ser danificado durante... certificar-se da correspondência...
...qu... transportada na sua embalagem de ori... cedor, pode ser danificado durante... certificar-se da correspondência...
...l, mesmo... cedor, pode ser danificado durante... certificar-se da correspondência...
...ento ao cli... certificar-se da correspondência...
...tário deve escrever to... da transportadora
... que perceba que existe... CARTA
TRADA AO TRANSPORTADOR

2 Red... ão para stock



DADOS TÉCNICOS – BOMBAS DE CALOR PRO ELYO INVERBOOST NN

Normas CE, R32, Carcaça em ABS

MODELO		PROELYXP07i	PROELYXP09i	PROELYXP11i	PROELYXP14i
CÓDIGO		71676	71677	71678	71679
* Desempenho no ar 28 °C, água 28°C, humidade 80%					
Potência calorífica	Kw	7-3.1	9-2.3	11-2.9	14-3.2
Potência consumida	Kw	1.04-0.21	1.34-0.14	1.64-0.18	2.09-0.2
COP		15-6.7	16-6.7	16-6.7	16-6.7
* Desempenho no ar 15 °C, água 26 °C, humidade 70%					
Potência calorífica	Kw	4.7-2.5	6.6-1.9	7.9-2	9.5-2.3
Potência consumida	Kw	0.94-0.32	1.32-0.24	1.58-0.25	1.9-0.29
COP		7.9-5	8.0-5	8.0-5	8.0-5
*Desempenho no ar 0 °C, água 26 °C, humidade 78%					
Potência calorífica	Kw	3.44-1.7	4.11-2.3	5.54-3.0	6.85-3.8
Potência consumida	Kw	1.23-0.38	1.47-0.82	1.98-0.68	2.45-0.85
COP		4.5-2.8	4.4-2.8	4.4-2.8	4.5-2.8
*Desempenho no ar -10 °C, água 26 °C, humidade 78%					
Potência calorífica	Kw	2.41-1.5	3.13-2.0	3.87-2.7	5.1-3.15
Potência consumida	Kw	1.21-0.35	1.42-0.53	1.76-0.69	2.32-0.81
COP		4.3-2	3.8-2.2	3.9-2.2	3.9-2.2
* Dados gerais					
Tipo de compressor		MITSUBISHI INVERTER COMPRESSOR			
Voltagem	V	220-240V/50Hz or 60Hz/1PH			
Corrente nominal	A	4.6	5.9	7.2	9.2
Fusível mínimo	A	7	9	11	14
Volume da piscina	m ³	10-26	12-35	16-60	18-66
Caudal de água	m ³ /h	2.5	3.0	3.7	4.0
Queda pressão de água	Kpa	12	12	14	15
Permutador de calor		Twist-titanium tube in PVC			
Conexão (água)	mm	50			
Nº de Ventiladores		1			
Tipo de ventilação		Horizontal			
Velocidade ventilador	RPM	500-850		550-850	
Pot. consumida vent.	W	6-35		22-82	32-110
Nível de ruído (10m)	dB(A)	≤ 41	≤ 42	≤ 42	≤ 43
Nível de ruído (1m)	dB(A)	38-51	39-52	40-52	40-54
Refrigerante (R32)	g	650	700	1000	1100
Equiv. CO2	Tonn	0.44	0.47	0.68	0.74
* Dimensão / Peso					
Peso líquido	kg	56	68	73	78
Peso bruto	kg	68	73	78	83
Dimensão net	mm	1008*380*577		1050*440*709	
Dimensão embalagem	mm	1095*430*705		1130*470*850	

* Os dados acima estão sujeitos a modificações sem aviso prévio.

DADOS TÉCNICOS – BOMBAS DE CALOR PRO ELYO INVERBOOST NN

Normas CE, R32, Carcaça em ABS

MODELO		PROELYXP16i	PROELYXP20i	PROELYXP26i	PROELYXP30i
CÓDIGO		71680	71681	71682	71683
* Desempenho no ar 28 °C, água 28 °C, humidade 80%					
Potência calorífica	Kw	16-3.8	20-4.7	26-5.9	30-6.8
Potência consumida	Kw	2.39-0.24	2.99-0.29	3.88-0.37	4.55-0.43
COP		16-6.7	16-6.7	16-6.7	16-6.6
* Desempenho no ar 15 °C, água 26 °C, humidade 70%					
Potência calorífica	Kw	11.2-3	14-3.9	18-5.4	22.8-5.6
Potência consumida	Kw	2.24-0.38	2.8-0.49	3.6-0.68	4.56-0.68
COP		8.2-5	8.2-5	8.2-5	8.2-5
* Desempenho no ar 0 °C, água 26 °C, humidade 78%					
Potência calorífica	Kw	7.4-4.1	9.79-4.8	13-6.7	15.89-8.5
Potência consumida	Kw	2.64-0.91	3.5-1.09	4.64-1.52	5.68-1.93
COP		4.5-2.8	4.4-2.8	4.4-2.8	4.4-2.8
* Desempenho no ar -10 °C, água 26 °C, humidade 78%					
Potência calorífica	Kw	5.8-3.6	7.58-4.3	10.4-5.9	12.74-7.4
Potência consumida	Kw	2.64-0.92	3.45-1.1	4.73-1.51	5.79-1.95
COP		3.9-2.2	3.9-2.2	3.9-2.2	3.8-2.2
* Dados gerais					
Tipo de compressor		MITSUBISHI INVERTER COMPRESSOR			
Voltagem	V	220V-240V/50Hz or 60Hz/1PH			
Corrente nominal	A	10.5	13.2	17.0	23.0
Fusível mínimo	A	16	20	26	35
Volume da piscina	m ³	28-85	58-120	65-132	78-156
Caudal de água	m ³ /h	5.0	6.0	8.0	10.0
Queda pressão de água	Kpa	15	18	20	25
Permutador de calor		Twist-titanium tube in PVC			
Conexão (água)	mm	50			
Nº de Ventiladores		1			
Tipo de ventilação		Horizontal			
Velocidade ventilador	RPM	450-650		(550-850)*2	
Pot. consumida vent.	W	35-130		(32-110)*2	
Nível de ruído (10m)	dB(A)	≤ 43	≤ 45	≤ 49	≤ 49
Nível de ruído (1m)	dB(A)	40-54	41-56	42-60	42-60
Refrigerante (R32)	g	1500	1900	2000	2600
Equiv. CO2	Tonne	1.01	1.28	1.35	1.76
* Dimensão / Peso					
Peso líquido	kg	98	117	128	130
Peso bruto	kg	113	135	146	148
Dimensão net	mm	1050*450*870		1050*452*1295	
Dimensão embalagem	mm	1140*480*1010		1130*515*1430	

* Os dados acima estão sujeitos a modificações sem aviso prévio.

DADOS TÉCNICOS – BOMBAS DE CALOR PRO ELYO INVERBOOST NN

Normas CE, R410A, Carcaça em ABS

MODELO		Pro Elyo Inverboost NN26T	Pro Elyo Inverboost NN 35	Pro Elyo Inverboost NN35T
CÓDIGO		68821	68822	68823
* Desempenho no ar 28 °C, água 28 °C, humidade 80%				
Potência calorífica	Kw	26-5.9	35-8	35-8
Potência consumida	Kw	3.88-0.37	5.22-0.5	5.22-0.5
COP		16-6.7	16-6.7	16-6.7
* Desempenho no ar 15 °C, água 26 °C, humidade 70%				
Potência calorífica	Kw	18-5.4	24-5.6	24-5.6
Potência consumida	Kw	3.6-0.68	4.8-0.68	4.8-0.68
COP		8.2-5	8.2-5	8.2-5
* Desempenho no ar 0 °C, água 26 °C, humidade 78%				
Potência calorífica	Kw	13-6.7	15.8-3.7	15.8-3.7
Potência consumida	Kw	4.64-1.52	4.46-0.63	4.46-0.63
COP		4.4-2.8	5.8-3.6	5.8-3.6
* Desempenho no ar -10 °C, água 26 °C, humidade 78%				
Potência calorífica	Kw	10.4-5.9	11.6-3.1	11.6-3.1
Potência consumida	Kw	4.73-1.51	4.77-0.6	4.77-0.6
COP		3.9-2.2	5.2-2.45	5.2-2.45
* Dados gerais				
Tipo de compressor		MITSUBISHI INVERTOR COMPRESSOR		
Voltagem	V	380V/50Hz or 60Hz/3PH	220~240V /50Hz or 60Hz/1PH	380V/50Hz or 60Hz/3PH
Corrente nominal	A	7	22.9	8.4
Fusível mínimo	A	10.5	34	13
Volume da piscina recomendado	m ³	65-132	78-160	78-160
Caudal de água	m ³ /h	8.00	10.0	10.0
Queda pressão de água	Kpa	20	25	25
Permutador de calor		Twist-titanium tube in PVC		
Conexão (água)	mm	50		
Nº de Ventiladores		2		
Tipo de ventilação		Horizontal		
Velocidade ventilador	RPM	(550-850)*2		
Pot. consumida vent.	W	(32-110)*2		
Nível de ruído(10m)	dB(A)	/	/	/
Nível de ruído (1m)	dB(A)	42-60	42-60	42-60
Refrigerante (R410a)	g	3800	4000	4000
Equiv. CO2	Tonne	7.94	8.36	8.36
* Dimensão / Peso				
Peso líquido	kg	128		
Peso bruto	kg	146		
Dimensão net	mm	1050*452*1295		
Dimensão embalagem	mm	1130*515*1430		

* Os dados acima estão sujeitos a modificações sem aviso prévio.

4.1 Lista de acessórios

		
Base anti vibração, 4 pcs	Jacto de drenagem, 2 peças	Caixa impermeável, 1 pc
		
Fio do sinal de 10M, 1 pc Fio de sinal Modbus, 1 pc	Montagem de conexão de água, 2 conjuntos	Capa de inverno, 1 pc

4.2 O Kit By-Pass

O kit By-Pass é o acessório essencial para a instalação da sua bomba de calor, é também uma ferramenta para a optimização do aquecimento da água. A regulação das válvulas permite otimizar o fluxo de água e com o manómetro para garantir o funcionamento optimizado do compressor, consulte o parágrafo 5.6 controles da pressão.



4.3 Accessories Installation

	<p>Bases anti vibração</p> <ol style="list-style-type: none"> 1. Retire 4 bases anti vibração 2. Colocá-los um por um na parte inferior da máquina como a imagem.
	<p>Jacto de drenagem</p> <ol style="list-style-type: none"> 1. Instale o jacto de drenagem sob o painel inferior 2. Conecte com um cano de água para drenar a água. <p>Nota: Levante a bomba de calor para instalar o jacto. Nunca derrube a bomba de calor, isso pode danificar o compressor.</p>
	<p>Entrada de água e junção de saída</p> <ol style="list-style-type: none"> 1. Use a fita de tubo para conectar a junção de entrada e saída de água na bomba de calor 2. Instale as duas juntas como mostra a imagem 3. Aparafusá-los na entrada de água e junção de saída
 	<p>Cabos de alimentação</p> <ol style="list-style-type: none"> 1. Abra a caixa do bloco de ligações (marcada a vermelho) localizada num dos lados da máquina 2. Fixe o outro lado nas juntas dentro da caixa eléctrica.
 	<p>Cabos da bomba de água (contacto seco)</p> <ol style="list-style-type: none"> 1. Abra a caixa do bloco de ligações (marcada a vermelho) no lado da máquina 2. Fixe o outro lado nas juntas dentro da caixa eléctrica.

2. Instale sempre a bomba de calor numa base sólida e monte sempre as bases e suportes fornecidas, para evitar vibrações excessivas.
3. Monte sempre a bomba de calor na posição vertical. Se a unidade de foi montada em ângulo, não ligue a bomba de calor antes de ligar a bomba de calor.

ATENÇÃO:

Nunca instale a unidade numa sala fechada com um volume de ar limitado, no qual o ar expulso da unidade será reutilizado, ou próximo a arbustos que possam bloquear a entrada de ar. Tais locais prejudicam o fornecimento com ar fresco.

5.2 Conexão da válvula de retenção

▲ NOTE

Nota: Se for utilizado equipamento de dosagem automática para cloro e acidez (pH), é essencial proteger a bomba de calor contra concentrações químicas excessivamente elevadas que possam corroer o permutador de calor. Por este motivo, equipamentos deste tipo devem sempre ser instalados na tubulação no lado a jusante da bomba de calor, e recomenda-se a instalação de uma válvula de retenção para evitar o fluxo reverso na ausência de circulação de água.

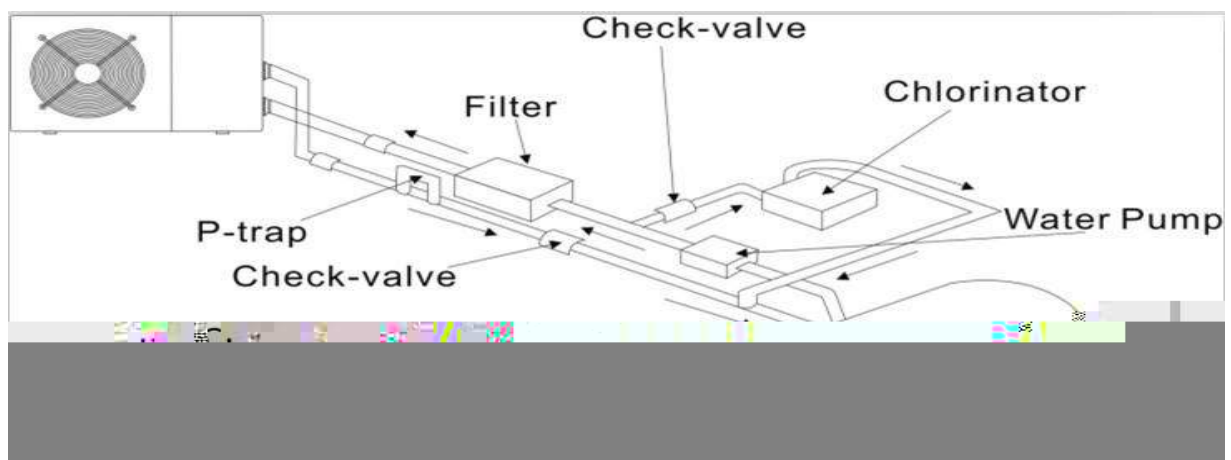

5.3 Arranjo típico

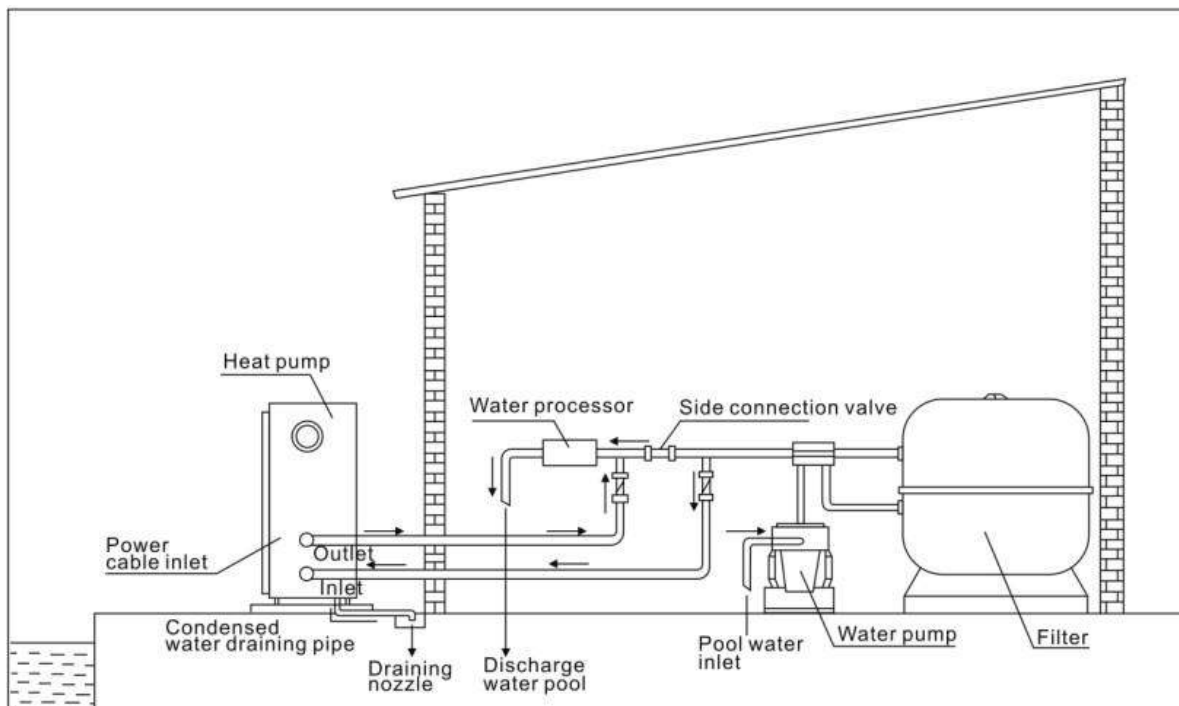

Este arranjo é apenas um exemplo ilustrativo.

▲ NOTE

A fábrica fornece apenas a bomba de calor. Todos os outros componentes, incluindo um bypass, se necessário, devem ser fornecidos pelo utilizador ou pelo instalador.

ATENÇÃO:

Para aquecer a água da piscina (ou banheira de água quente), a bomba do filtro deve estar funcionando para fazer com que a água circule pela bomba de calor. A bomba de calor não iniciará se a água não estiver circulando.

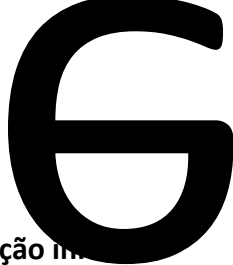

5.4 Operação Inicial

Após todas as conexões terem sido feitas e verificadas, execute o seguinte procedimento:

1. Ligue a bomba do filtro. Verifique se há vazamentos e se a água está a circular, de e para, a piscina.
2. Conecte a energia á bomba de calor e pressione o botão On/Off  no painel de controle electrónico. A unidade será iniciada após o tempo de atraso de inicialização (ver abaixo).
3. Depois de alguns minutos, verifique se o ar que sai da unidade está mais frio.
4. Quando desligar a bomba do filtro, a unidade também deve desligar automaticamente, se não desligar será necessário afinar o interruptor de fluxo.

Dependendo da temperatura inicial da água na piscina e da temperatura do ar, pode levar vários dias para aquecer a água até à temperatura desejada. Uma boa cobertura de piscina pode reduzir drasticamente o tempo necessário.

NOTA

Interruptor de fluxo de água:

Bomba de calor vem equipada com interruptor de fluxo para protecção contra a ausência de caudal adequado. Que permitirá ligar o equipamento quando a bomba da piscina funcionar e impedir o seu funcionamento quando a bomba de piscina for desligada.

Tempo de atraso - A bomba de calor tem um atraso de inicialização de 3 minutos para proteger o circuito e evitar o desgaste excessivo dos contactos. A unidade será reiniciada automaticamente após esse tempo expirar. Mesmo que a unidade seja interrompida de

5.5 Condensação

O ar aspirado para a bomba de calor é fortemente arrefecido pela operação da bomba de calor para aquecimento da água da piscina, o que pode causar condensação nas alhetas do evaporador.

NOTA

A quantidade de condensação pode ser tanto maior for a humidade relativa (vários litros por hora em alta humidade relativa). O que por vezes pode ser erroneamente considerado como uma fuga água.

5.6 Visor do manómetro (R32)

Examine o manómetro que indica a pressão do gás refrigerante da unidade, a tabela abaixo mostra o valor normal da pressão do gás (R32) quando a máquina está desligada ou em condições de funcionamento.

Estado da Unidade	Desligada			
Ambiente (°C)	-5~5	5~15	15~25	25~35
Temperatura da água (°C)	/	/	/	/
Medidor de pressão (Mpa)	0.59~0.85	0.85~1.18	1.18~1.59	1.59~2.1

Estado da Unidade	Em funcionamento				
Ambiente (°C)	/	/	/	/	/
Temperatura da água (°C)	10~15	15~20	20~25	25~30	30~35
Medidor de pressão (Mpa)	1.1~1.6	1.3~1.8	1.5~2.1	1.7~2.4	1.9~2.7

6.1 Diagrama eléctrico da bomba de calor de piscina Inverter

Ref. 71676/71677/71678/71679/71680

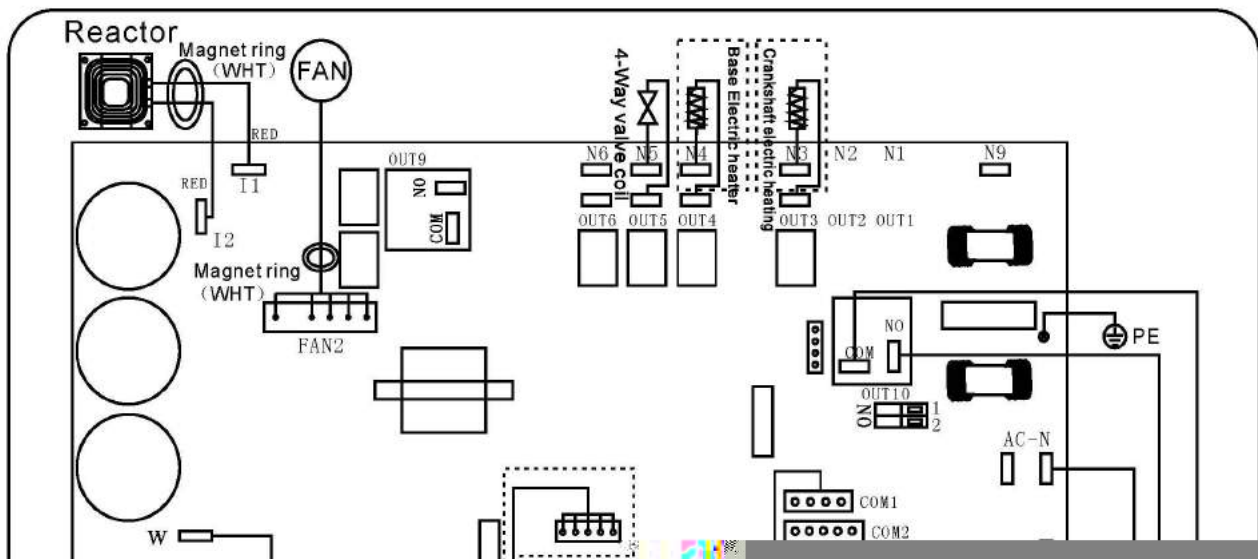

6.2 Diagrama eléctrico da bomba de calor de piscina Inverter

Ref: 71681

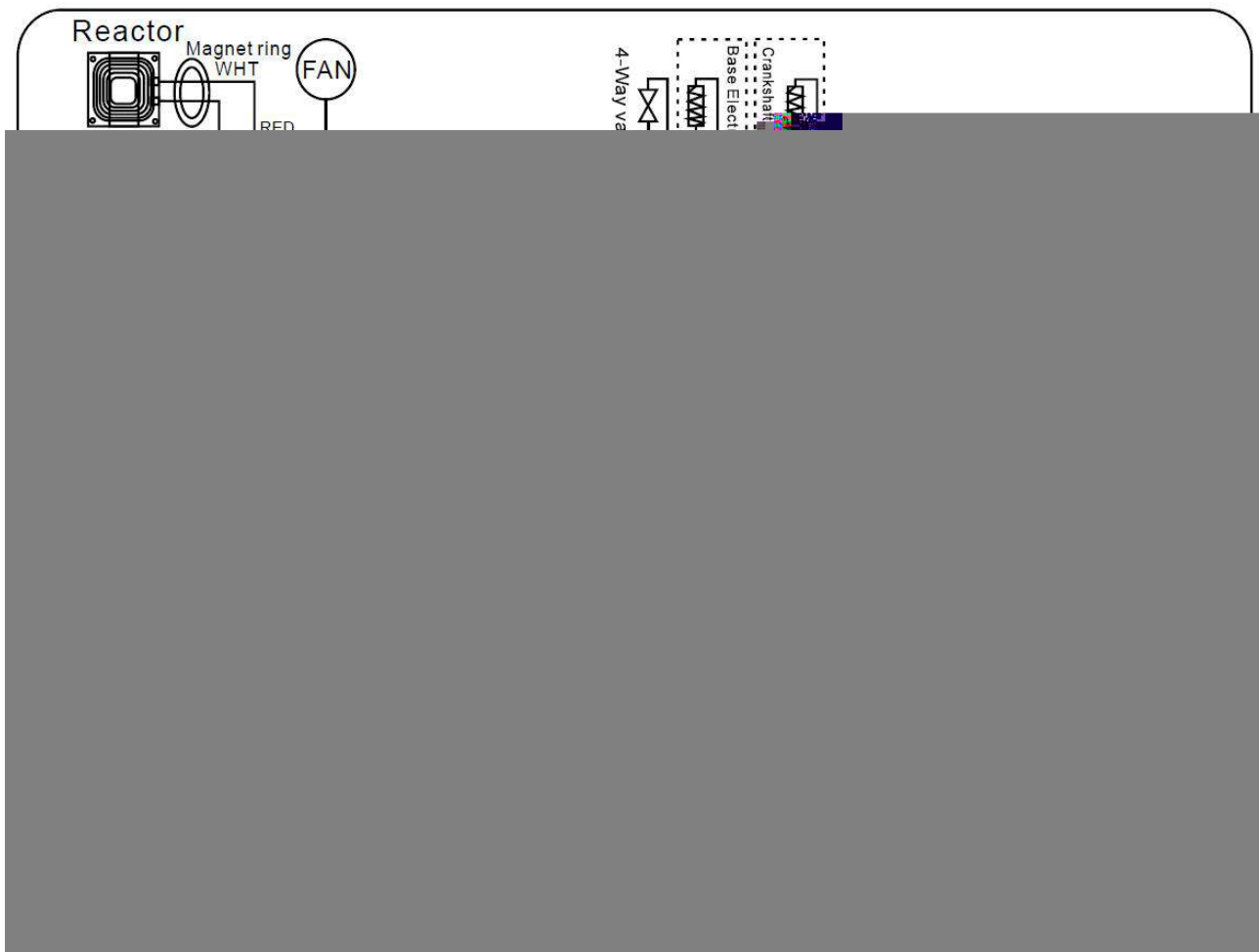

6.3 Diagrama eléctrico da bomba de calor de piscina Inverter

Ref: 71682/71683



6.4 Diagrama eléctrico da bomba de calor de piscina Inverter

Ref. 68822 (R410A)

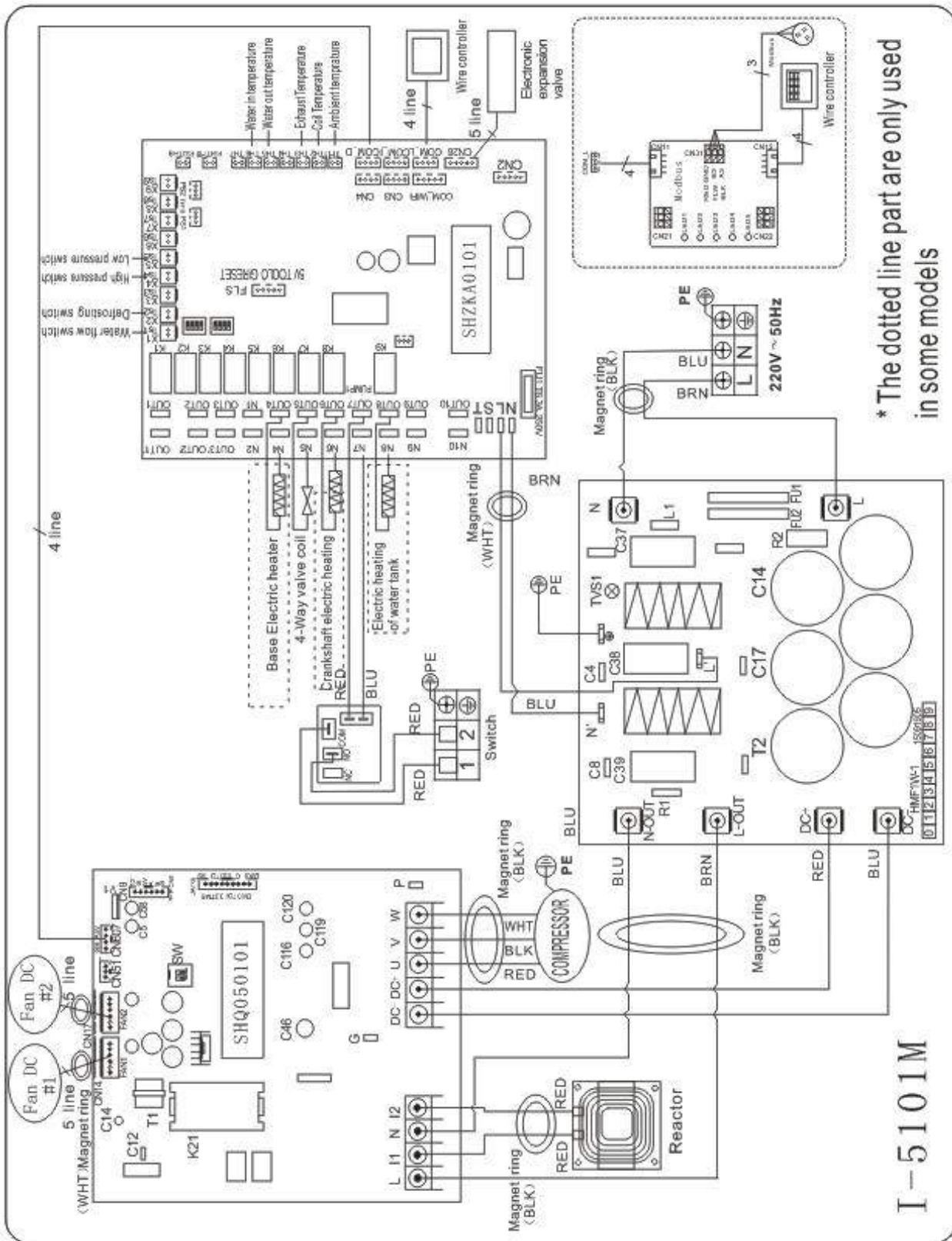

6.5 Diagrama eléctrico da bomba de calor de piscina Inverter Ref. 68821/68823 (R410A)

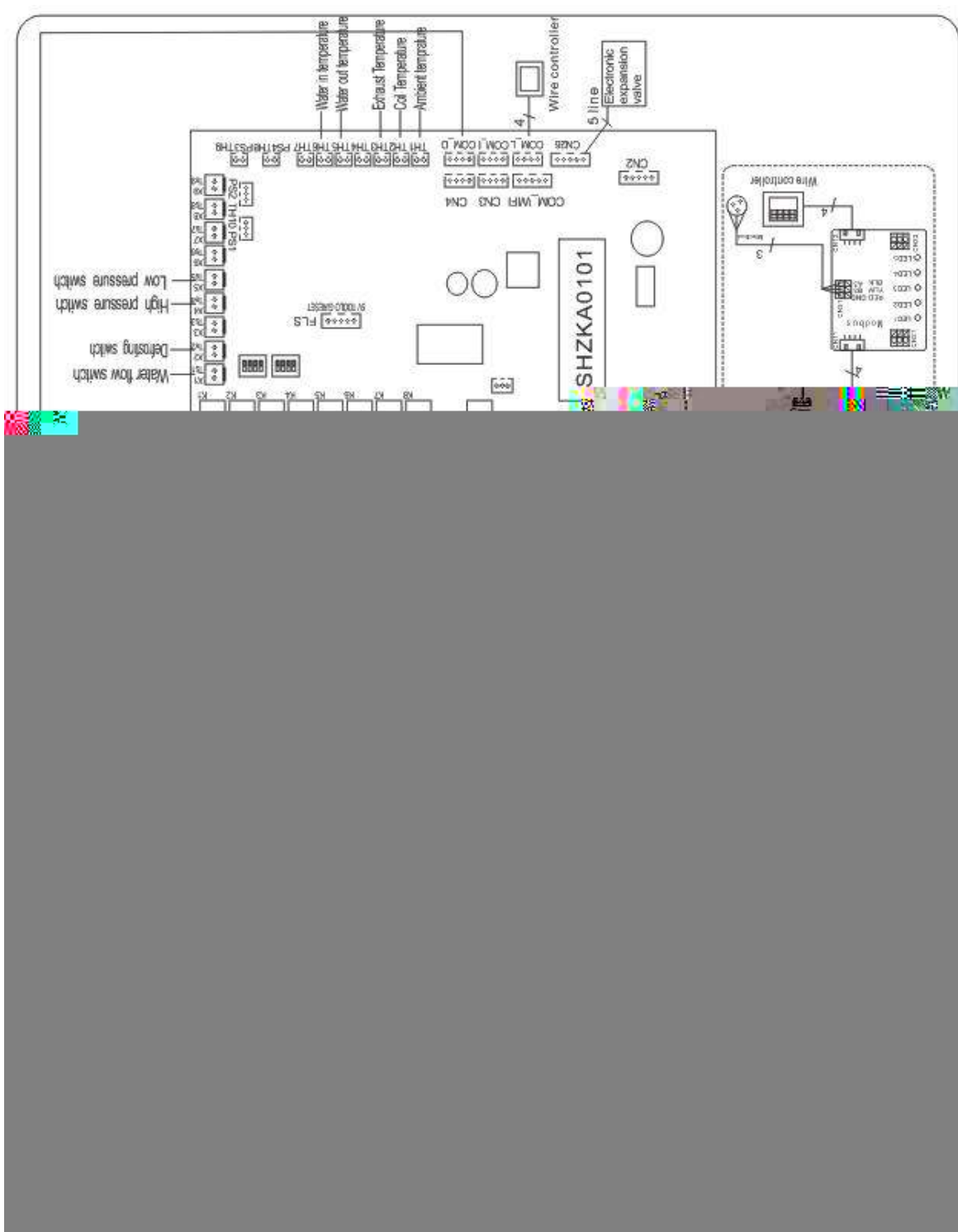

* Os diagramas de cablagem eléctrica indicados acima, são apenas a título indicativo. Por favor verificar sempre o diagrama que está afixado na máquina.

6.6 Protecção eléctrica

O fornecimento de energia eléctrica para a bomba de calor, deve vir preferencialmente, de um circuito eléctrico exclusivo, com componentes de protecção regulamentados (protecção diferencial 30mA) e um interruptor magneto-térmico.

- A instalação eléctrica deve ser realizada por profissional especializado (electricista com carteira profissional) de acordo com as normas e regulamentos vigentes no país de instalação.
 - O circuito da bomba de calor deve ser conectado a um circuito de aterramento de segurança no bloco de terminais.
 - Os cabos devem ser instalados correctamente para evitar interferência.
 - Pressupõe-se que a bomba de calor seja ligada a uma fonte de alimentação geral com conexão à terra.
 - Secção do cabo; Esta secção é indicativa e deve ser verificada e adaptada de acordo com as necessidades e condições de uso.
 - A tolerância da variação de tensão aceitável é de +/- 10% durante o funcionamento.
- As conexões devem ser dimensionadas de acordo com a potência do dispositivo e o estado do instalação.

Modelos	Disjuntor	Comprimento máximo do cabo			
		2,5 mm ²	4 mm ²	6 mm ²	10 mm ²
PROELYXP07i	7 A	84 m	135 m	200 m	335 m
PROELYXP09i	9 A	57 m	90 m	130 m	225 m
PROELYXP11i	11A				
PROELYXP14i	14 A	43 m	68 m	100 m	170 m
PROELYXP16i	16 A	34 m	54 m	80 m	135 m
PROELYXP20i	20 A	29 m	45 m	66 m	110 m
PROELYXP26i	26 A	/	25 m	38 m	62 m
PROELYXP30i	35 A	/	/	22 m	36 m
PRO ELYO INVERBOOST NN 26T	9 A	15 m	35 m	49 m	81 m
PRO ELYO INVERBOOST NN 35	34 A	/	/	22 m	36 m
PRO ELYO INVERBOOST NN 35T	13 A	12 m	27 m	39 m	68 m



Estes valores são fornecidos a título indicativo, somente a intervenção de um técnico autorizado pode determinar os valores correspondentes à sua instalação.

A linha eléctrica deve ser equipada com uma conexão à terra e com um disjuntor diferencial de 30mA na cabeça.

6.7 Instalação do painel de controlo

Foto(1)



Foto(2)



Foto(3)

Foto(4)



Foto(5)

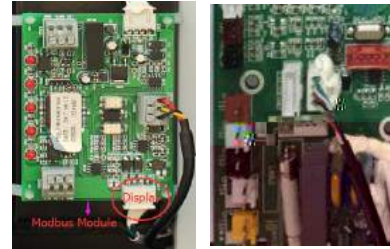

- O lado com ficha, liga-se ao painel de controlo (foto1)
- O outro lado do cabo de sinal. (foto2)
- Abra o painel dos terminais e coloque o lado sem plug através da caixa eléctrica. (foto3,4)
- Insira a cablagem na posição designada na placa de circuito impresso (Módulo Modbus ou PCB sem Modbus). (foto5)

6.8 Instalação do Modbus/ Cabo de conexão Fluidra Connect

Photo(6)



Photo(7)

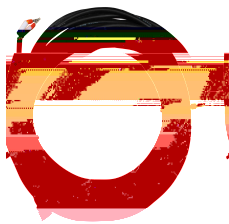

Photo(8)



Photo(9)

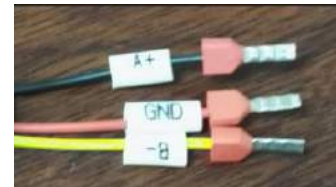

- Abra a tampa dos terminais (foto6)
- Segure no fio de sinal Modbus / Fluidra Connect dos acessórios (foto 7) e coloque a ponta arredondada do fio de sinal no fio de sinal do Modbus / Fluidra Connect Module. (foto 8)
- Terminal de três fios: "A +", "B-", "GND" (Foto 9)

7. Operação do controlador

7.1. Guia para operação

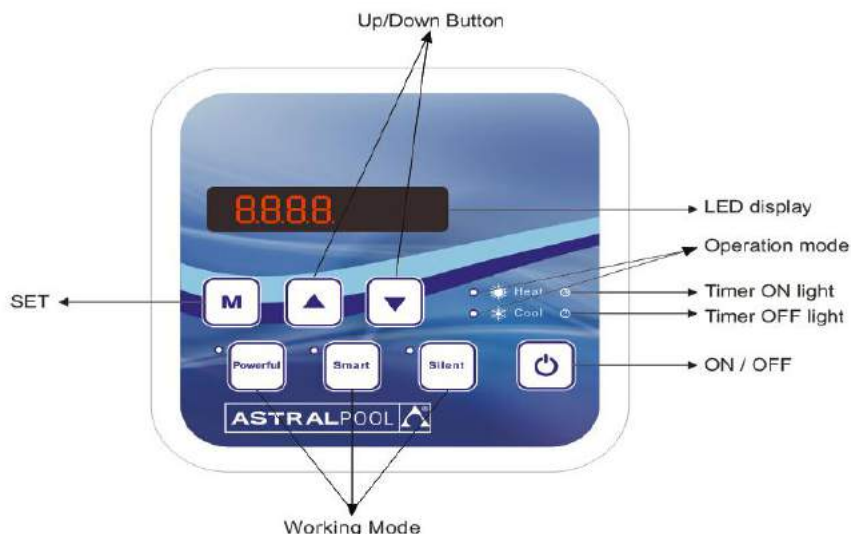



NOTA: Sempre que a bomba de calor se conecta à energia, o display LED mostra um código durante 3 segundos, que indica o modelo da bomba de calor.

7.2 Teclas e operação

7.2.1 Botão



Pressione  para iniciar a unidade de bomba de calor, o display de LED mostra a temperatura da água desejada por 5 segundos, em seguida, mostra a temperatura da água de entrada e o modo de operação.

Pressione  para parar a unidade de bomba de calor e mostrar "OFF"

Aviso: Durante a verificação e configuração de parâmetros, pressione  para sair rapidamente e salvar a configuração actual.

Pressione  novamente para ligar / desligar a máquina.

7.2.2 Botão





Pressione  por 5 segundos para alternar o modo de aquecimento e modo automático.

7.2.3 Botão



Bloquear / desbloquear o visor:

Pressione simultaneamente  e  por 5 segundos para bloquear / desbloquear a tela.

Temperatura da água:

Pressione  ou  para definir a temperatura da água diretamente.

Verificação de parâmetros:

Prima  primeiro e depois prima  para verificar os parâmetros de utilizador de d0 a d14

Código	Condição	Escopo	Observação
d0	Temperatura do modulo IPM	0-120°C	Valor real do teste
d1	Temperatura de Entrada de água.	-9°C~99°C	Valor real do teste
d2	Temperatura de Saída de água.	-9°C~99°C	Valor real do teste
d3	Temperatura ambiente.	-30°C~70°C	Valor real do teste
d4	Código de limitação de frequência	0,1,2,4,8,16	Valor real do teste
d5	Temperatura do circuito	-30°C~70°C	Valor real do teste
d6	Temperatura de exaustão do gás	0°C ~C5°C (125°C)	Valor real do teste
d7	Etapa do EEV	0~99	N * 5
d8	Frequência de funcionamento do compressor	0~99Hz	Valor real do teste
d9	Corrente do compressor	0~30A	Valor real do teste
d10	Velocidade actual do ventilador	0-1200 (rpm)	Valor real do teste
d11	Último código de erro	Todos os códigos de erro	
d12	MOBUS COM	0 - 5	Config. só p/ Modbus
d13	Endereço de ID do MODBUS	1 - 88	Config. só p/ Modbus
d14	Código do produto	0000- FFFF	Config. só p/ Modbus

Nota: d4: Código de limitação de frequência

0: Sem limite de frequência,

1: Limite de temperatura da bobina,

2: Limite de frequência de sobreaquecimento ou sobrearrefecimento

4: Limite de frequência actual do inversor,

8: Limite de frequência de tensão de accionamento,

16: Limite de frequência de alta temperatura.

automaticam ente

Prima



primeiro e de

ficar os

0 a P7

Código com CONNECT	Parâmetro P	Descrição
71676	17FC	PAC PROELYXP07i 7-3.1Kw
71677	17FD	PAC PROELYXP09i 9-2.3Kw
71678	17FE	PAC PROELYXP11i 11-2.9Kw
71679	17FF	PAC PROELYXP14i 14-3.2Kw
71680	1800	PAC PROELYXP16i 16-3.8Kw
71681	1801	PAC PROELYXP20i 20-4.7Kw
71682	1802	PAC PROELYXP26i 26-5.9Kw
71683	1803	PAC PROELYXP30i 30-6.8Kw
68821	0CD5	PAC PROELYO INVERBOOST NN 26T 26-5.9Kw
68822	0CD6	PAC PROELYO INVERBOOST NN 35 35-8Kw
68823	0CD7	PAC PROELYO INVERBOOST NN 35T 35-8Kw

Parâmetro do código do produto P (Apenas Modbus):

Prima + durante 5 segundos, o primeiro número digital pisca, prima ou para escolher o número seguida ã mero.

Após a configuração, o parâmetro de código do produto P não pode ser redefinido, mesmo que o sistema seja redefinido. Seu valor de configuração é sempre mantido.

7.2.4 Função de reset do sistema

Pressione  e  por 10s, o sistema irá fazer reset e exibir "0000" no controlador.

7.2.5 Heat

Símbolo de aquecimento, a luz estará acesa quando estiver em operação.
Ao descongelar, a luz piscará.

7.2.6 Cool

Símbolo de arrefecimento, a luz estará acesa quando estiver em operação.

7.2.7

Símbolo de paragem automática, a luz estará acesa quando estiver em operação.

7.2.8

Símbolo de partida automática, a luz estará acesa quando estiver em operação.

7.2.9

Pressione o botão "Powerfull", a luz ficará a piscar, a bomba de calor operará somente em "Full output".

7.2.10 Smart

Se escolher "Smart, a bomba de calor funcionará apenas em "Medium output" e "Full output"

Quando em "Saída média", a luz do Smart piscará.

Quando em "Full output", a luz Smart estará acesa e a luz de "Powerful" estará piscando.

7.2.11 Silent

Escolhendo o modo "Silent", a bomba de calor irá operar apenas em "Medium output" e "Small output"

Quando em 'Small output', a luz do "Silent" piscará.

Quando em " Medium output ", a luz do "Silent" acende, e a luz do Smart ficará piscando.

7.2.12 Modo automático:

Existem 3 opções de funcionamento, “apenas aquecimento”, modo “Auto” (interruptor de aquecimento e arrefecimento), e “apenas arrefecimento”.

Pode-se alternar o modo “apenas aquecimento e “Auto” pressionando  por 5 segundos, independentemente de a unidade estar ligada ou desligada.



Lógica de operação do modo Automático:

de interruptor. Quando a bomba de calor entra no modo de espera (standby), a bomba de água não comprime. A bomba de água irá funcionar por 3 minutos e depois parará quando o tempo de espera superior a 2 horas.

Modo de aquecimento	Condição	Exemplo	Lógica de trabalho da bomba de água
Modo de aquecimento	$T1 > Tset - 1$, dura 30 minutos	$T1 > 27^{\circ}C$, dura 30 minutos	A bomba de água entrará no modo de espera por 2 horas e não será iniciada, excepto se o seu

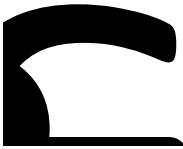

7.3 Lógica de operação de aquecimento

Status de trabalho	Modo de trabalho	Água em temperatura T1	Por exemplo, água na temperatura T1	Nível de funcionamento da bomba de calor	
1	Arranque da bomba de calor	SMART	$T1 < Tset-1$	$T1 < 27^{\circ}C$	Modo "Powerfull" - frequência F9
2			$Tset-1 \leq T1 < Tset$	$27^{\circ}C \leq T1 < 28^{\circ}C$	Frequência: F9-F8-F7, ...-F2
3			$Tset \leq T1 < Tset+ 1$	$28^{\circ}C \leq T1 < 29^{\circ}C$	Modo "Silent"-frequência F2
4			$T1 \geq Tset+1$	$T1 \geq 29^{\circ}C$	A BC estará em standby, parada até que a temperatura da água caia para menos de $28^{\circ}C$.
5		SILENT	$T1 < Tset$	$T1 < 28^{\circ}C$	Modo "Smart" - frequência F5.
6			$Tset \leq T1 < Tset+1$	$28^{\circ}C \leq T1 < 29^{\circ}C$	Frequência de modo "Silent" F2 / F1.
7			$T1 \geq set+1$	$T1 \geq 9^{\circ}C$	BC estará em modo standby, parada até que a temperatura da água caia para menos de $28^{\circ}C$.
8		POWERFUL	$T1 < Tset+1$	$T1 < 29^{\circ}C$	Modo "Powerful" frequência F10 / F9
9			$T1 \geq Tset+1$	$T1 \geq 29^{\circ}C$	BC estará em modo standby, parada até que a temperatura da água caia para menos de $28^{\circ}C$.
10	Reiniciar para aquecer desde status standby	SMART	$T1 \geq Tset$	$T1 \geq 28^{\circ}C$	Standby
11			$Tset > T1 \geq Tset-1$	$28^{\circ}C > T1 \geq 27^{\circ}C$	F2 de frequência "Silent"
12			$Tset-1 > T1 \geq Tset-2$	$27^{\circ}C > T1 \geq 26^{\circ}C$	Frequência: F2-F3-F4, ..., - F9
13		$< Tset-2$	$< 26^{\circ}C$	Frequência "Powerful" F9	
14		SILENT	$\geq Tset$	$\geq 28^{\circ}C$	Standby
15			$Tset > T1 \geq Tset-1$	$28^{\circ}C > T1 \geq 27^{\circ}C$	Modo "Silent" - frequência F2 / F1
16			$T1 < Tset-1$	$T1 < 27^{\circ}C$	Frequência "Smart" F5
17	POWERFUL	$T1 < Tset-1$	$T1 < 27^{\circ}C$	Frequência "Powerful" F10 / F9	

7.4 Lógica de operação de refrigeração

Status de trabalho Modo de trabalho Água em temperatura Por exemplo, a água
T1

8.1 Exibição de código de erro no controlador de fio de LED

Mau funcionamento	Erro de código	Razão	Solução
Falha no sensor de temperatura da água de entrada T1-TH6	PP01	<ol style="list-style-type: none"> 1. Sensor em circuito aberto ou em c.circ. 2. O cabo do sensor está solto 	<ol style="list-style-type: none"> 1. Verifique ou mude o sensor 2.Reaperte cablagem dos sensores
Falha do sensor de temperatura da água de saída T2-TH5	PP02	<ol style="list-style-type: none"> 1. Sensor em circuito aberto ou em c.circ. 2. O cabo do sensor está solto 	<ol style="list-style-type: none"> 1. Verifique ou mude o sensor 2.Reajuste a fiação dos sensores
Falha no sensor da tubulação de aquecimento T3-TH2	PP03	<ol style="list-style-type: none"> 1. Sensor em circuito aberto ou em c.circ. 2. O cabo do sensor está solto 	<ol style="list-style-type: none"> 1. Verifique ou mude o sensor 2.Reajuste a fiação dos sensores
Falha do sensor de retorno de gás	PP04	<ol style="list-style-type: none"> 1. Sensor em circuito aberto ou em c.circ. 2. O cabo do sensor está solto 	<ol style="list-style-type: none"> 1. Verifique ou mude o sensor 2.Reajuste a fiação dos sensores
Falha do sensor de temperatura ambiente T5-TH1	PP05	<ol style="list-style-type: none"> 1. Sensor em circuito aberto ou em c.circ. 2. O cabo do sensor está solto 	<ol style="list-style-type: none"> 1. Verifique ou mude o sensor 2.Reajuste a fiação dos sensores
Falha do sensor da tubulação de exaustão T6-TH3	PP06	<ol style="list-style-type: none"> 1. Sensor em circuito aberto ou em c.circ. 2. O cabo do sensor está solto 	<ol style="list-style-type: none"> 1. Verifique ou mude o sensor 2.Reajuste a fiação dos sensores
Protecção anti congelamento no inverno	PP07	Temperatura ambiente ou temperatura de entrada de água é muito baixa	Protecção normal
Protecção - Baixa temperatura ambiente	PP08	<ol style="list-style-type: none"> 1.Para além do âmbito de funcionamento 2. Anormalidade do sensor 	<ol style="list-style-type: none"> 1. Parar de usar, está para além do âmbito de funcionamento 2.Substituir o sensor

Mau funcionamento	Erro de código	Razão	Solução
Falha de baixa pressão TS5	EE02	<ol style="list-style-type: none"> 1. A válvula electrónica de expansão (EEV) bloqueou, ou o sistema hidráulico está bloqueado. 2. A velocidade do motor é anormal ou o motor está danificado 3. Fuga de gás 	<ol style="list-style-type: none"> 1. Verificar o sistema de EEV e de tubulação Verifique o motor 2. Através do manómetro de alta pressão, verificar o valor da pressão
Falha de fluxo de água TS1	EE03 Or" ON"	<ol style="list-style-type: none"> 1. Interruptor de fluxo de água está danificado 2. Não existe caudal de água ou é insuficiente. 	<ol style="list-style-type: none"> 1. Trocar o interruptor de fluxo de água 2. Verificar a bomba de água ou o sistema hidráulico
Protecção Sobreaquecimento temp. da água (T2-TH5) no modo de aquecimento	EE04	<ol style="list-style-type: none"> 1. Baixo fluxo de água 2. O interruptor de fluxo de água está bloqueado e/ou circuito hidráulico interrompido 3. Anomalia no sensor T2-TH5 	<ol style="list-style-type: none"> 1. Verificar o circuito hidráulico 2. Verificar a bomba de água e o estado do interruptor de fluxo de água 3. Verificar sensor de temp. T2-TH5 e se necessário substituir.
Protecção Sonda de temperatura de descarga T6-TH3 muito alta.	EE05	<ol style="list-style-type: none"> 1. Falta de gás 2. Baixo fluxo de água 3. Pipingsystem foi bloqueado 4. Falha do sensor de Temp. de descarga. 	<ol style="list-style-type: none"> 1. Verificar o manómetro de alta pressão. Se estiver muito baixo, preencha com algum gás. 2. Verifique o sistema hidráulico e a bomba de água 3. Verificar se existe algum bloqueio 4. Substituir sensor de temp de descarga
Falha do controlador	EE06	<ol style="list-style-type: none"> 1. Fios danificados ou conexões deficientes. 2. Falha do controlador 	<ol style="list-style-type: none"> 1. Verificar e refazer as conexões dos cabos de sinal 2. Substituir cabos de sinal 3. Cortar a alimentação eléctrica e reinicie a máquina. 4. Substituir o controlador
Protecção – corrente do compressor	EE07	<ol style="list-style-type: none"> 1. Corrente do compressor é instantaneamente muito elevada. 2. Conexão incorrecta para sequência de fase do compressor 3. Acumulações de líquido e óleo no compressor levam aumento da corrente. 4. Compressor ou placa de controlo danificados. 5. O fluxo de água anormal 6. Flutuações na alimentação dentro de um curto período de tempo 	<ol style="list-style-type: none"> 1. Verificar o compressor 2. Verificar o sistema hidráulico 3. Verificar se a alimentação está dentro do intervalo admissível. 4. Verificar a conexão da sequência de fase

Mau funcionamento	Erro de código	Razão	Solução
Falha de comunicação entre o controlador e a placa principal	EE08	<ol style="list-style-type: none"> 1. Conexão deficiente ou cabo de sinal danificado 2. Mau funcionamento do controlador 	<ol style="list-style-type: none"> 1. Verifique e refaça a conexão do cabo de sinal 2. Substituir cabo de sinal 3. Desligue o fornecimento de electricidade e reinicie a máquina 4. Substituir controlador
Falha de comunicação entre a placa principal e a placa de controlo	EE09	<ol style="list-style-type: none"> 1. Conexão deficiente do cabo de comunicação 2. Cabo danificado 	<ol style="list-style-type: none"> 1. Verifique a ligação do cabo 2. Substituir cabo
Protecção - VDC muito alta	EE10	<ol style="list-style-type: none"> 1. Tensão da linha mãe é muito alta 2. A placa de controlo está danificada. 	<ol style="list-style-type: none"> 1. Verifique se a alimentação está no intervalo normal 2. Substituir a placa de controlo ou a placa principal
Protecção do módulo IPM (Inverter Power Module)	EE11	<ol style="list-style-type: none"> 1. Erro de dados 2. Conexão incorrecta da fase do compressor 3. O líquido do compressor e a acumulação de óleo, levam a que a corrente aumente 4. Compressor ou placa de controlo danificada 	<ol style="list-style-type: none"> 1. Erro de programa, desligue o fornecimento de electricidade e reinicie após 3 minutos 2. Trocar a placa de controlo 3. Verifique a conexão/sequência das fases ao compressor
Protecção - VDC muito baixa	EE12	<ol style="list-style-type: none"> 1. Tensão da linha mãe é muito baixa 2. A placa de controlo está danificada. 	<ol style="list-style-type: none"> 1. Verifique se a energia está no intervalo normal 2. Trocar a placa de controlo
Protecção - Corrente de entrada alta.	EE13	<ol style="list-style-type: none"> 1. A corrente do compressor é momentaneamente muito elevada 2. O fluxo de água é anormal 3. Flutuações de energia dentro de um curto período de tempo 4. Indutor PFC errado 	<ol style="list-style-type: none"> 1. Verifique o compressor 2. Verifique o sistema hidráulico 3. Verifique se a energia está na faixa normal 4. Verifique se o indutor PFC é o correcto
Erro de saída do circuito de detecção de temperatura do módulo IPM (Inverter Power Module)	EE14	<ol style="list-style-type: none"> 1. Anomalia no Output do circuito térmico do módulo IPM 2. O motor do ventilador está com anomalias ou danificado 3. Lâmina do ventilador está danificada 	<ol style="list-style-type: none"> 1. Trocar a placa de controlo 2. Verificar se a velocidade do motor está muito baixa ou se o motor do ventilador está danificado, trocar se necessário 3. Trocar pás do ventilador

Mau funcionamento	Erro de código	Razão	Solução
Protecção - Temperatura elevada do módulo IPM	EE15	<ol style="list-style-type: none"> 1. Output exception do circuito de detecção de temperatura do módulo IPM 2. Motor está com anomalia ou danificado 3. Pás do ventilador, danificadas 	<ol style="list-style-type: none"> 1. Trocar uma placa de controlo 2. Verificar se a velocidade do motor do ventilador está muito baixa ou se o motor do ventilador está danificado, trocar se necessário 3. Trocar as pás do ventilador
Protecção do módulo PFC	EE16	<ol style="list-style-type: none"> 1. Output exception do módulo PFC 2. Motor com anomalias ou danificado 3. Pás do ventilador, danificadas 4. Salto de tensão de entrada, a potência de entrada é anormal 	<ol style="list-style-type: none"> 1. Alterar uma placa de controlo 2. Verifique se a velocidade do motor está muito baixa ou se o motor do ventilador está danificado, trocar se necessário 3. Trocar as pás do ventilador 4. Verificar a tensão de entrada
Falha do motor do ventilador DC	EE17	<ol style="list-style-type: none"> 1. O motor DC está danificado 2. A placa principal está danificada 3. As pás do ventilador estão presas 	<ol style="list-style-type: none"> 1. Verificar o motor DC, substituir se necessário 2. Trocar placa principal 3. Eliminar o bloqueio das pás
Falha do circuito interno de detecção de temperatura do módulo PFC	EE18	A placa de controlo está danificada	<ol style="list-style-type: none"> 1. Trocar placa de controlo 2. Verificar se a velocidade do motor do ventilador está muito baixa ou se o motor do ventilador está danificado, trocar se necessário.
Protecção- temperatura elevada do módulo PFC	EE19	<ol style="list-style-type: none"> 1. Anomalia na saída do circuito térmico do módulo PFC 2. Motor está com anomalia ou danificado 3. Pás do ventilador, danificadas 4. O parafuso na placa de controlo não está apertado 	<ol style="list-style-type: none"> 1. Trocar placa de controlo 2. Verificar se a velocidade do motor está muito baixa ou se o motor do ventilador está danificado, trocar se necessário 3. Trocar as pás do ventilador 4. Verifique se o parafuso está solto
Falha de energia de entrada	EE20	A tensão de alimentação flutua demasiado	Verifique se a voltagem está estável

Mau funcionamento	Erro de código	Razão	Solução
Erro no controlo de software	EE21	1. Compressor funciona fora de fase 2. Programa incorrecto 3. Impurezas dentro do compressor causa instabilidade na velocidade de rotação	1. Verificar a placa principal e substituir se necessário 2. Introduzir o software correcto
Falha no circuito de detecção de corrente.	EE22	1. Sinal de tensão anormal 2. A placa de controlo está danificada	1. Verificar a placa principal e substituir se necessário 2. Trocar placa de controlo
Falha no arranque do compressor	EE23	1. A placa principal está danificada 2. Erro na cablagem do compressor ou mau contacto ou desconectado 3. Acumulação de líquido no interior 4. Conexão de fase errada	1. Verifique a placa principal e trocar se necessário 2. Verificar a cablagem do compressor de acordo com o diagrama de circuito 3. Verificar o compressor, trocar se necessário
Erro placa de controlo-temperatura ambiente	EE24	Falha do dispositivo de temperatura ambiente	Trocar placa de controlo ou placa principal
Falha de fase do compressor	EE25	U, V, W conectados a uma fase ou a duas fases.	Verificar se as ligações estão de acordo com o diagrama de circuito
Falha de inversão de válvula de quatro vias	EE26	1. Falha de inversão na válvula de quatro vias 2. Falta de refrigerante (não detecta mau funcionamento do T3-TH2 ou T5-TH1)	1. Mudar para o modo de refrigeração para verificar a válvula de 4 vias se esta tiver sido invertida correctamente 2. Trocar válvula de 4 vias 3. Encha com gás
Erro de leitura de dados da EEPROM	EE27	1. Dados errados da EEPROM no programa ou falha na entrada de dados da EEPROM 2. Falha da placa principal	1. Reinsere os dados correctos da EEPROM 2. Trocar placa principal
A falha de comunicação entre chips na placa principal	EE28	Falha da placa principal	1. Desligue a alimentação eléctrica e reinicie a máquina 2. Trocar a placa principal

8.1 Protecção da unidade

Observações:

1. No modo de aquecimento, se a temperatura de saída de água for maior que a temperatura definida, acima de 7°C, o controlador exibirá EE04 para protecção contra sobreaquecimento da água.
2. No modo de refrigeração, se a temperatura de saída de água for inferior à temperatura definida, acima de 7°C, o controlador exibirá PP11 para protecção contra arrefecimento excessivo da água.

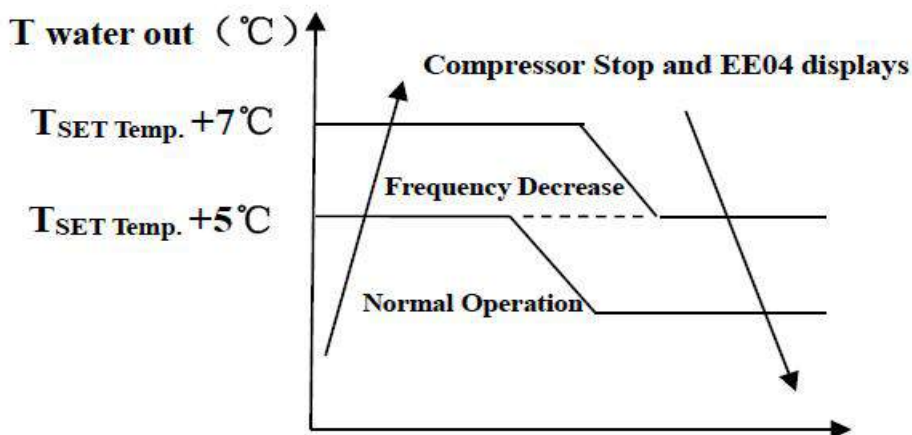

EE04 Protecção Contra Sobreaquecimento da Água

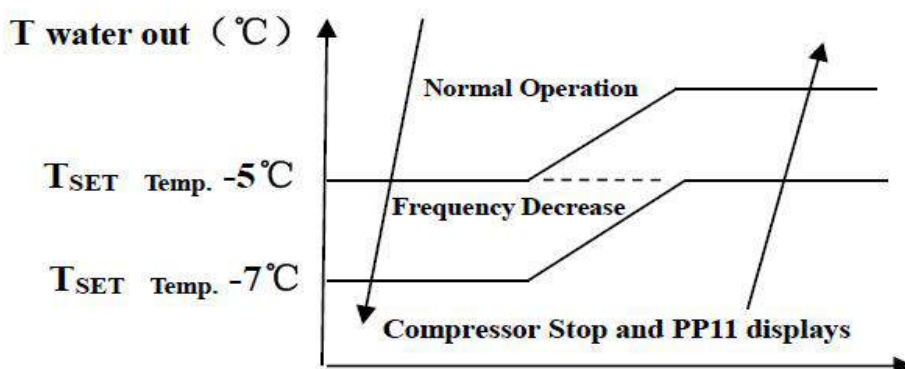

PP11 Protecção contra arrefecimento excessivo da água

Por exemplo:

Modo	Água fora de temperatura	Temperatura de ajuste	Condição	Defeituoso
Modo de aquecimento	36°C	29°C	$T_{out} - T_{set} \geq 7^{\circ}\text{C}$	EE04 Protecção contra sobreaquecimento da água (T2)
Modo de arrefecimento	23°C	30°C	$T_{set} - T_{out} \geq 7^{\circ}\text{C}$	PP11 Protecção contra temperatura da água muito baixa (T2)

8.2 Outros defeitos e soluções (sem display no controlador)

Mau	Observando	Razão	Solução
Bomba de calor não está a funcionar	Controlador não exibe nada no display	Nenhuma fonte de alimentação	Verifique se o cabo e o disjuntor estão ligados
	Controlador exibe a hora real.	Bomba de calor em standby	Inicializar a bomba de calor para funcionar.
	Controlador exibe a temperatura real da água.	1.A temperatura da água está a chegar ao valor de ajuste, a bomba de calor encontra-se em estado de temperatura constante. 2.A bomba de calor está a começar a funcionar. 3. Em descongelação.	1. Verifique a configuração da temperatura da água. 2. Inicie a bomba de calor depois de alguns minutos. 3. O controlador deve exibir "Descongelação".
A água arrefece quando a BC funciona em modo de aquecimento	O controlador exibe a temperatura real da água e nenhum indicador de código de erro.	1. Escolha o modo errado. 2. Figuras mostram defeitos. 3. Defeito do controlador.	1. Ajustar o modo para o funcionamento correto 2. Substituir o controlador e em seguida, verifique o status após alterar o modo de operação, verificando a temperatura de entrada e saída da água. 3. Substituir ou reparar a bomba de calor
Corrida curta	O controlador exibe a temperatura real da água, nenhum código de erro é exibido.	1. Ventilador NÃO está a funcionar. 2. Ventilação de ar não é suficiente. 3. O refrigerante não é suficiente.	1. Verifique as conexões do cabo entre o motor e o ventilador, se necessário, deve ser substituído. 2. Verifique a localização da bomba de calor e elimine todos os obstáculos para obter uma boa ventilação do ar. 3 Substitua ou repare a bomba de calor.
Manchas na água	Manchas de água na bomba de calor.	1. Cobertura protecção. 2. Fuga de água.	1. Nenhuma acção. 2. Verifique o permutador de calor de titânio com cuidado e se há algum defeito ou fuga.
Muito gelo no evaporador	Muito gelo no evaporador.		1. Verifique a localização da bomba de calor e elimine todos os obstáculos para obter uma boa ventilação do ar. 2. Substitua ou repare a bomba de calor.

9. 1 Diagrama explodido

Mod.: 71676

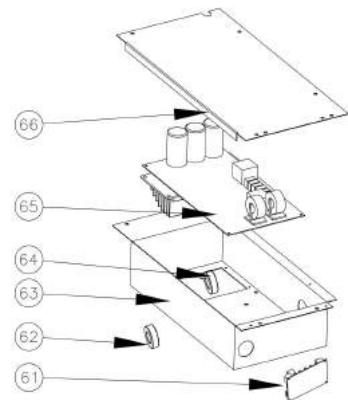
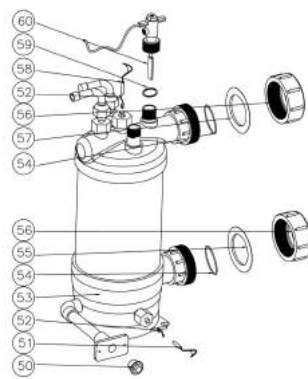
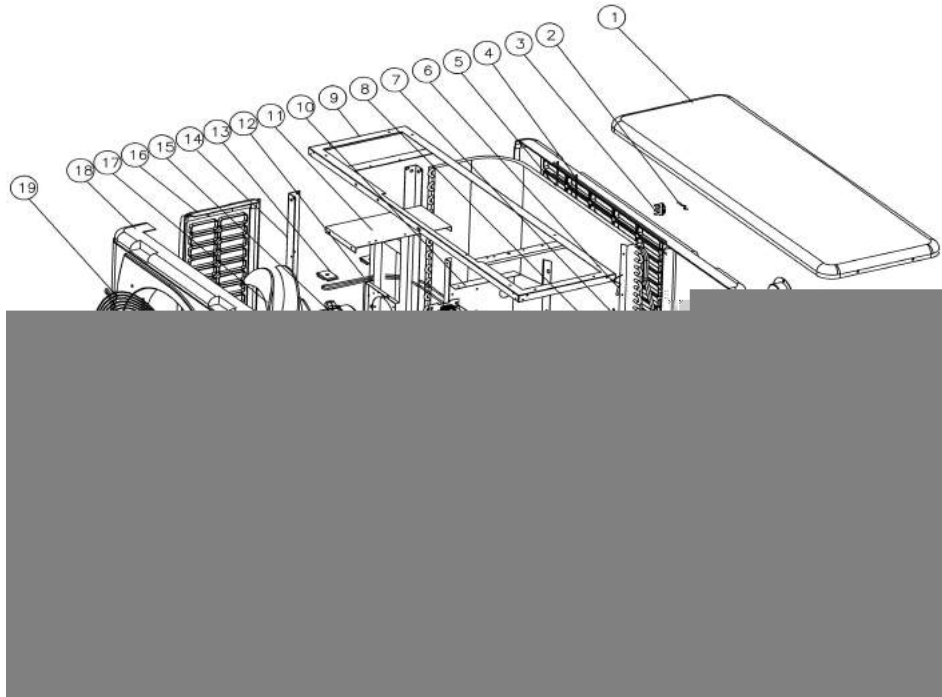

9.2 Lista de peças de reposição : 71676

NO	ERP	Designação	NO	CÓD.FÁB.	Designação
1	1330900291	Tampa superior	34	117020180	Controlador
2	117110020	Temperatura ambiente. sensor T5-TH1	35	103000227	Tubulação coletiva
3	133020010	Temperatura ambiente. clipe de sensor	36	136020018	Borracha
4	1330900271	Painel traseiro	37	103000227	Tubulação de distribuição
5	103000227	Evaporador	38	106000011	Medidor de pressão
6	117110004	Pipe temp. sensor T3-TH2	39	113020320	Tubulação de retorno de gás
7	113190001	Tubo de revestimento do sensor	40	113080074	EEV para encanamento de distribuição
8	113190001	grampo	41	113070042	Trocador para EEV
9	108110038	Quadro superior	42	119000017	EEV
10	108050073	Painel de isolamento	43	116000071	Interruptor de baixa pressão
11	108110043	Suporte do motor do ventilador	44	117110021	Temp. De exaustão sensor T6-TH3
12	142000058	Correia de aquecimento do evaporador	45	113010229	Tubo de escape
13	108480015	fixador de cintos	46	113030081	Válvula de 4 vias para trocador
14	108110004	Pilar	47	116000066	Interruptor de alta pressão
15	112000031	Motor de ventilador	48	113060123	Tubo
16	1330900261	Painel do lado esquerdo	49	121000006	Válvula de 4 vias
17	132000015	Lâmina da ventoínha	50	150000110	Plugue de drenagem
18	1330900251	Painel frontal	51	117110012	Água em temp. sensor T1-TH6
19	108010014	Grelha frontal	52	108010025	Clipe do sensor de temperatura do permutador
20	117230003	Reactor	53	102040705	Trocador de calor de titânio
21	101000187	Pés de amortecimento do compressor	54	133020026	Anel de borracha na conexão de água
22	142000072	Correia de aquecimento do compressor	55	133020011	Anel de borracha azul
23	101000187	Compressor	56	113900082	Conjuntos de conexão de água
24	113100008	Ferramenta de acoplamento	57	133020011	Anel de borracha vermelha
25	120000091	Válvula global	58	117110011	Água fora temp. sensor T2-TH5
26	180140064	Bandeja base	59	116000001	Anel de vedação
27	108010065	Terminal Board	60	112100021-1	Interruptor de fluxo de água
28	115000004	Terminal de 5 assentos	61	117010095	Módulo Modbus
29	113100009	Grampo	62	117240002	anel magnético
30	1330900281	Painel direito	63	108110057	Caixa elétrica
31	1332500051	Tampa plástica dos blocos de terminais	64	117240003	Anel magnético
32	108010018	Caixa de fiação	65	117100046	PCB
33	113712007	Caixa do controlador à prova d'água	66	108050017	Tampa da caixa elétrica

9.3 Model: 71677/71678/71679

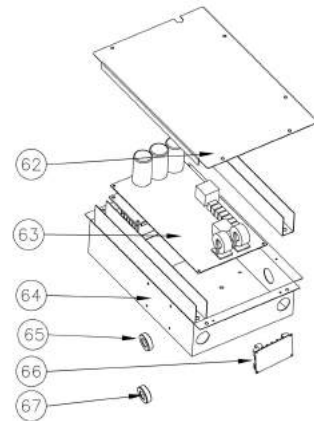
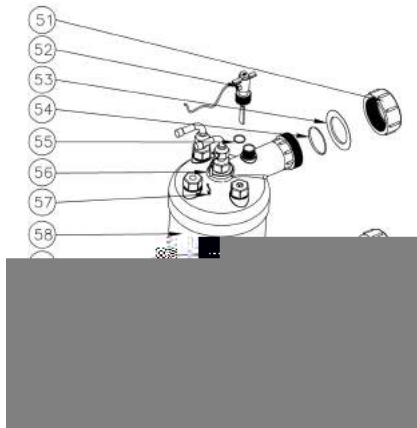
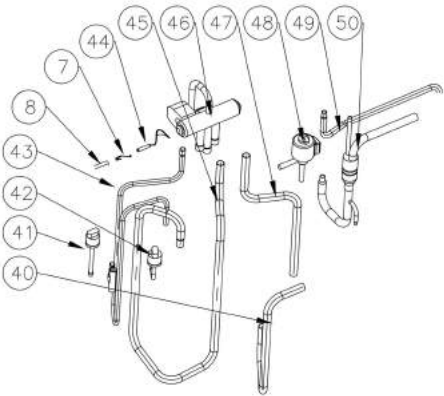
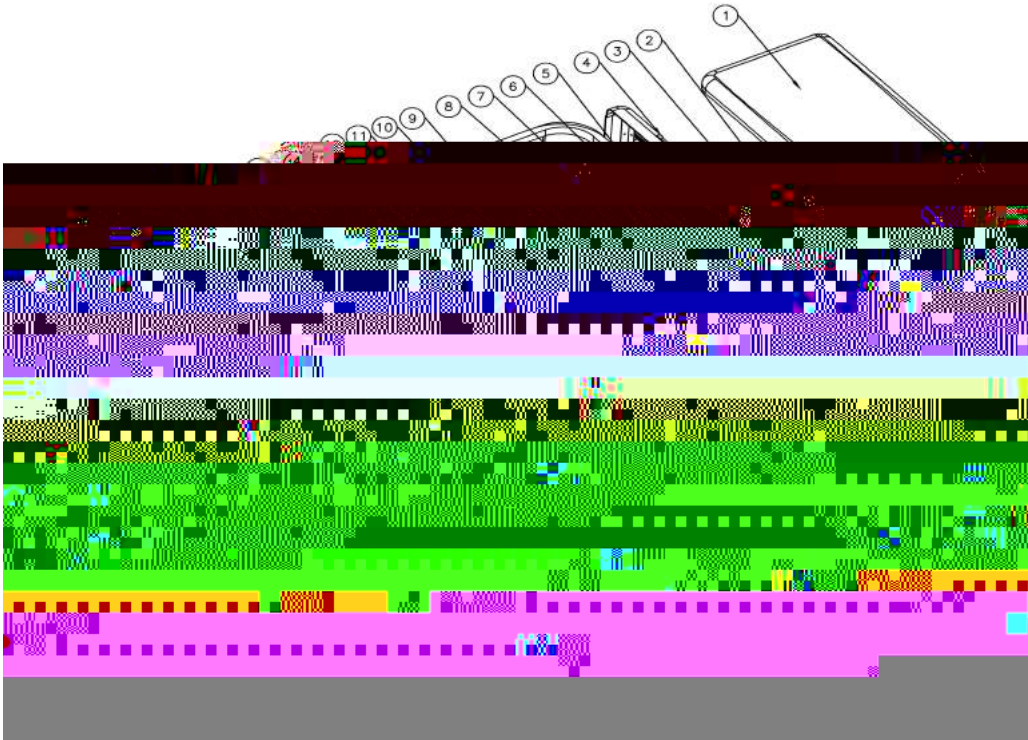

9.4 Lista de peças de reposição : 71677

NO	CÓD.FÁB.	Designação	NO	CÓD.FÁB.	Designação
1	1330900291	Tampa superior	35	113712007	Caixa do controlador à prova d 'água
2	117110020	Temperatura ambiente. sensor T5-TH1	36	117020180	Controlador
3	133020010	Temperatura ambiente. clipe de sensor	37	103000221	Montagem de tubulação colectiva
4	1330900271	Painel traseiro	38	136020005	Bloco de borracha
5	103000221	Evaporador	39	103000221	Montagem de tubulação de distribuição
6	117110004	Pipe temp. sensor T3-TH2	40	113030086	Válvula de 4 vias para trocador
7	113100009	Grampo	41	116000066	Interruptor de alta pressão
8	113100009	Tubo de revestimento do sensor	42	116000071	Interruptor de baixa pressão
9	108110038	Quadro superior	43	113010210	Tubo de escape
10	108110043	Suporte do motor do ventilador	44	117110021	Temp. De exaustão sensor T6-TH3
11	117230003	Reactor	45	113020322	Tubulação de retorno de gás
12	108480015	Braçadeira de cinto	46	121000006	Válvula de 4 vias
13	108110004	Pilar	47	113060084	Válvula de 4 vias para tubulação colectiva
14	142000079	Correia de aquecimento do evaporador	48	119000017	EEV
15	112000031	Motor de ventilador	49	113080054	EEV para encanamento de distribuição
16	1330900261	Painel do lado esquerdo	50	113070044	Trocador para EEV
17	108010024	Tampa do tubo do motor DC	51	113900082	Conjuntos de conexão de água
18	132000015	Lâmina da ventoinha	52	112100021-1	Interruptor de fluxo de água
19	1330900251	Painel frontal	53	133020012	Anel de borracha vermelha
20	108010014	Grelha frontal	54	133020026	Anel de borracha na conexão de água
21	108050073	Painel de isolamento	55	136020083	Anel de vedação
22	113100008	Tubo de cobre	56	117110011	Água fora temp. sensor T2-TH5
23	120000091	Válvula global	57	108010025	Clipe do sensor de temperatura do permutador
24	142000074	Cinto de aquecimento do compressor	58	102040748	Trocador de calor de titânio
25	101000188	Pés de Compressor	59	133020011	Anel de borracha azul
26	101000188	Compressor	60	117110012	Água em temp. sensor T1-TH6
27	108110066	Bandeja base	61	150000110	Plugue de drenagem
28	108010065	Terminal Board	62	108050017	Tampa da caixa elétrica
29	133090028	Painel direito	63	117100046	PCB
30	106000011	Medidor de pressão	64	108110031	Caixa elétrica
31	136010004	Grampo	65	117240002	Anel magnético
32	115000004	Terminal de 5 assentos	66	117010095	Módulo Modbus
33	1332500051	Tampa plástica dos blocos de terminais	67	117240003	Anel magnético
34	133030011	Caixa de fiação			

9.5 Lista de peças de reposição : 71678

NO	CÓD.FÁB.	Designação	NO	CÓD.FÁB.	Designação
1	1330900291	Tampa superior	34	133030011	Caixa de fiação
2	117110020	Temperatura ambiente. sensor T5-TH1	35	113712007	Caixa do controlador à prova d 'água
3	133020010	Temperatura ambiente. clipe de sensor	36	117020180	Controlador
4	1330900271	Painel traseiro	37	103000182	Tubulação colectiva
5	103000182	Evaporador	38	136020005	Borracha em forma de B
6	117110004	Pipe temp. sensor T3-TH2	39	103000182	Tubulação de distribuição
7	113100009	Tubo de revestimento do sensor	40	113030086	Válvula de 4 vias para trocador
8	113100009	Grampo	41	116000066	Interruptor de alta pressão
9	108110038	Quadro superior	42	116000071	Interruptor de baixa pressão
10	108110043	Suporte do motor do ventilador	43	113010210	Tubo de escape
11	117230003	Reactor	44	117110021	Temp. De exaustão sensor T6-TH3
12	108480015	Fixador de cinto	45	113020322	Tubulação de retorno de gás
13	108110004	Pilar	46	121000006	Válvula de 4 vias
14	142000079	Correia de aquecimento do evaporador	47	113060084	Válvula de 4 vias para tubulação colectiva
15	112000031	Motor de ventilador	48	119000017	EEV
16	1330900261	Painel do lado esquerdo	49	113080054	EEV para encanamento de distribuição
17	108010024	Tampa do tubo do motor DC	50	113070044	Trocador para EEV
18	132000015	Lâmina da ventoinha	51	113900082	Conjuntos de conexão de água
19	133090025	Painel frontal	52	112100021-1	Interruptor de fluxo de água
20	108010014	Grelha frontal	53	133020011	Anel de borracha vermelha
21	108050073	Painel de isolamento	54	133020026	Anel de borracha na conexão de água
22	113100008	Ferramenta de acoplamento	55	116000001	Anel de vedação
23	120000091	Válvula global	56	117110011	Água fora temp. sensor T2-TH5
24	142000074	Correia de aquecimento do compressor	57	117110012	Clipe do sensor de temperatura do permutador
25	101000188	Pés de amortecimento do compressor	58	102040708	Trocador de calor de titânio
26	101000188	Compressor	59	133020011	Anel de borracha azul
27	108110066	Bandeja base	60	117110012	Água em temp. sensor T1-TH6
28	108010065	Terminal Board	61	150000110	Plugue de drenagem
29	1330900281	Painel direito	62	108050017	Tampa da caixa elétrica
30	106000011	Medidor de pressão	63	117100047	PCB
31	136010004	Grampo	64	108110057	Caixa elétrica
32	115000004	Terminal de 5 assentos	65	117240002	Anel magnético
33	1332500051	Tampa plástica dos blocos de terminais	66	117010095	Módulo Modbus
			67	117240003	Anel magnético

9.6 Lista de peças de reposição: 71679

Quantidade	Referência	Descrição	Quantidade	Referência	Descrição
1	108110039	Motor	1	10300035	Caixa de controle e prova d'água
1	117110004	Temp. sensor	1	117110180	Controlador
3	13301010	Temperatura ambiente clipes	37	103000220	Tubulação colectora
4	13300004	Clipes base	38	16020005	Borracha em forma de b
5	103000220	Evaporador	39	103000220	Tubulação de distribuição
6	117110004	Pipe temp. sensor T6-TH3	40	113030081	Válvula de 4 vias para trocador
7	113100009	Tubo de revestimento do sensor	41	116000066	Interruptor de alta pressão
8	113100009	Exemplo	42	116000071	Interruptor de baixa pressão
9	108110038	Quadro superior	43	113010159	Tubo de escape
10	108110043	Suporte do motor do ventilador	44	117110021	Temp. De exaustão sensor T6-TH3
11	117230003	Reactor	45	113020321	Tubulação de retorno de gás
12	108480015	Clipes de cinto de aquecimento do evaporador	46	101000006 03	Válvula de 4 vias
13	108110004	Pilar	47	1130006	

9.7 Modelo: 71680/71681

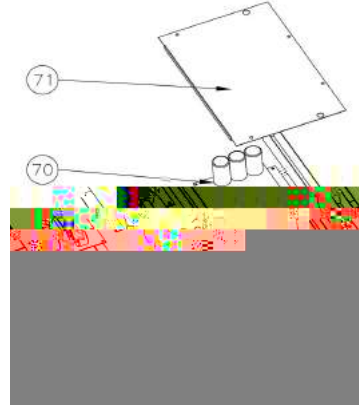
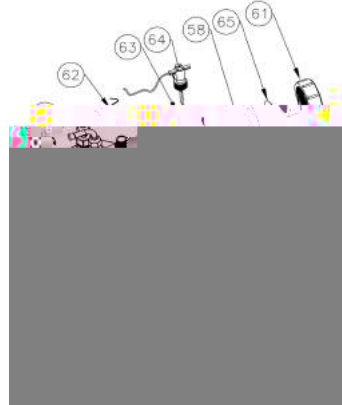
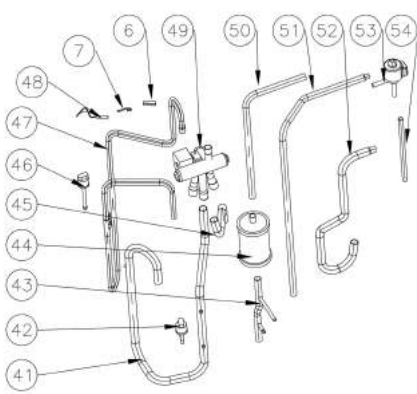
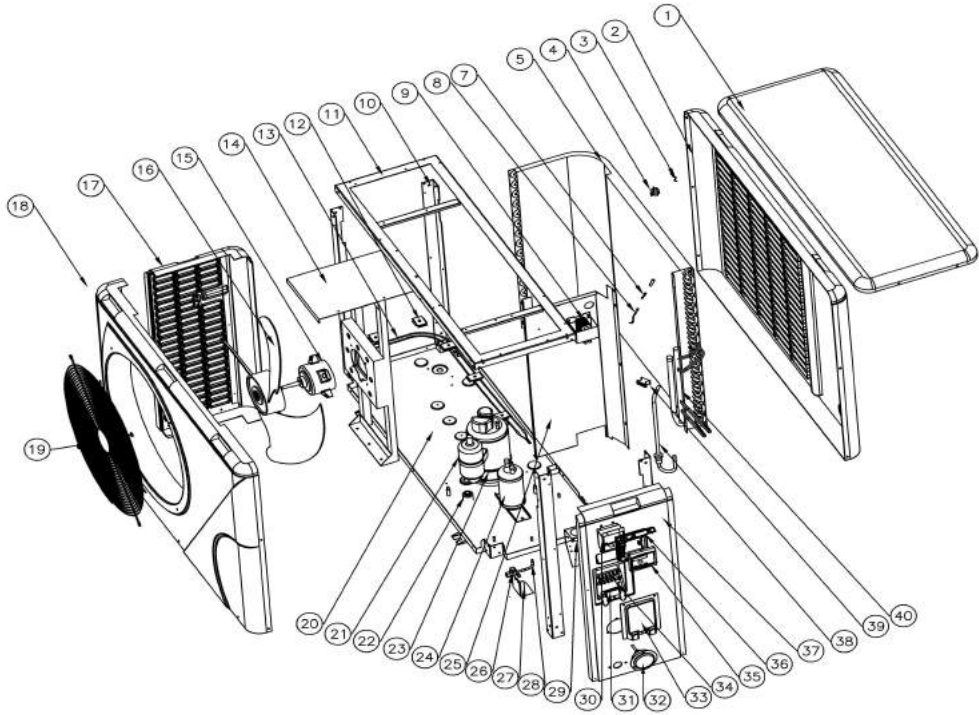

9.8 Lista de peças de reposição: 71680

NO	CÓD.FÁB.	Nome de peças de reposição	NO	CÓD.FÁB.	Nome de peças de reposição
1	1332600011	Tampa superior	37	1332600041	Painel direito
2	1332600021	Painel traseiro	38	103000230	Montagem de tubulação de distribuição
3	117110020	Temperatura ambiente. sensor T5-TH1	39	136020005	Bloco de borracha
4	133020010	Temperatura ambiente. clipe de sensor	40	103000230	Montagem de tubulação colectiva
5	103000230	Evaporador	41	113020338	Tubulação de retorno de gás
6	113100009	Tubo de revestimento do sensor	42	116000073	Interruptor de baixa pressão
7	113100009	Grampo	43	113130021	Filtro para tanque de armazenamento de líquidos
8	117110004	Pipe temp. sensor T3-TH2	44	120000066	Filtro
9	117230002	Reactor	45	113060122	Válvula de 4 vias para tubulação coletiva
10	108560003	Pilar	46	116000068	Interruptor de alta pressão
11	108560002	Quadro superior	47	113010244	Tubo de escape
12	108480015	Braçadeira de cinto	48	117110021	Temp. De exaustão sensor T6-TH3
13	142000079	Correia de aquecimento do evaporador	49	121000006	Válvula de 4 vias
14	108560011	Suporte do motor do ventilador	50	113170032	Trocador para filtrar
15	112000031	Motor de ventilador	51	113120019	Tanque de armazenamento de líquidos para EEV
16	132000023	Lâmina da ventoínha	52	113030108	Válvula de 4 vias para trocador
17	1332600051	Painel do lado esquerdo	53	119000021	EEV
18	1332600031	Painel frontal	54	113080056	EEV para encanamento de distribuição
19	108170017	Grelha frontal	55	150000110	Plugue de drenagem
20	108560036	Bandeja base	56	108010025	Clipe do sensor de temperatura do permutador
21	101000185	Compressor	57	117110012	Água em temp. sensor T1-TH6
22	101000185	Pés de Compressor	58	133020026	Anel de borracha na conexão de água
23	142000077	Cinto de aquecimento do compressor	59	133020011	Anel de borracha azul
24	105000004	Tanque de armazenamento de líquido	60	102040703	Trocador de calor de titânio
25	108560010	Painel de isolamento	61	113900082	Conjuntos de conexão de água
26	120000091	Válvula global	62	117110011	Água fora temp. sensor T2-TH5
27	108560034	Placa de válvula globo	63	136020083	Anel de vedação
28	113100008	Tubo de cobre	64	112100021-1	Interruptor de fluxo de água
29	108010065	Terminal Board	65	133020012	Anel de borracha vermelha
30	133030011	Caixa de fiação	66	117010095	Módulo Modbus
31	136010004	Grampo	67	117240002	Anel magnético
32	106000011	Medidor de pressão	68	117240003	Anel magnético
33	1332500051	Tampa plástica dos blocos de terminais	69	108560012	Caixa elétrica
34	115000004	Terminal de 5 assentos	70	117100048	PCB
35	117020180	Controlador	71	108540006	Tampa da caixa elétrica
36	113712007	Caixa do controlador à prova d'água			

9.9 Lista de peças de reposição: 71681

NO	CÓD.FÁB.	Nome de peças de reposição	NO	CÓD.FÁB.	Nome de peças de reposição
1	1332600011	Tampa superior	37	1332600041	Painel direito
2	1332600021	Painel traseiro	38	103000204	Montagem de tubulação de distribuição
3	117110020	Temperatura ambiente. sensor T5-TH1	39	136020005	Bloco de borracha
4	133020010	Temperatura ambiente. clipe de sensor	40	103000204	Montagem de tubulação colectiva
5	103000204	Evaporador	41	113020339	Tubulação de retorno de gás
6	113100009	Tubo de revestimento do sensor	42	116000073	Interruptor de baixa pressão
7	113100009	Grampo	43	113130021	Filtro para tanque de armazenamento de líquidos
8	117110004	Pipe temp. sensor T3-TH2	44	120000066	Filtro
9	117230002	Reactor	45	113060096	Válvula de 4 vias para tubulação colectiva
10	108560003	Pilar	46	116000068	Interruptor de alta pressão
11	108560002	Quadro superior	47	113010245	Tubo de escape
12	108480015	Braçadeira de cinto	48	117110021	Temp. De exaustão sensor T6-TH3
13	142000144	Correia de aquecimento do evaporador	49	121000009	Válvula de 4 vias
14	108560011	Suporte do motor do ventilador	50	113170032	Trocador para filtrar
15	112000031	Motor de ventilador	51	113120019	Tanque de armazenamento de líquidos para EEV
16	132000023	Lâmina da ventoinha	52	113030093	Válvula de 4 vias para trocador
17	1332600051	Painel do lado esquerdo	53	119000021	EEV
18	1332600031	Painel frontal	54	113080056	EEV para encanamento de distribuição
19	108170017	Grelha frontal	55	150000110	Plugue de drenagem
20	108560036	Bandeja base	56	108010025	Clipe do sensor de temperatura do permutador
21	101000185	Compressor	57	117110012	Água em temp. sensor T1-TH6
22	101000185	Pés de Compressor	58	133020026	Anel de borracha na conexão de água
23	142000077	Cinto de aquecimento do compressor	59	133020011	Anel de borracha azul
24	105000004	Tanque de armazenamento de líquido	60	102040764	Trocador de calor de titânio
25	108560010	Painel de isolamento	61	113900082	Conjuntos de conexão de água
26	120000091	Válvula global	62	117110011	Água fora temp. sensor T2-TH5
27	108560034	Placa de válvula globo	63	136020083	Anel de vedação
28	113100008	Tubo de cobre	64	112100021-1	Interruptor de fluxo de água
29	108010065	Terminal Board	65	133020012	Anel de borracha vermelha
30	133030011	Caixa de fiação	66	117010095	Módulo Modbus
31	136010004	Grampo	67	117240002	Anel magnético
32	106000011	Medidor de pressão	68	117240003	Anel magnético
33	1332500051	Tampa plástica dos blocos de terminais	69	108560012	Caixa elétrica
34	115000004	Terminal de 5 assentos	70	117100048	PCB
35	117020180	Controlador	71	108540006	Tampa da caixa elétrica
36	113712007	Caixa do controlador à prova d 'água			

9.10 Modelo: 71682,71683

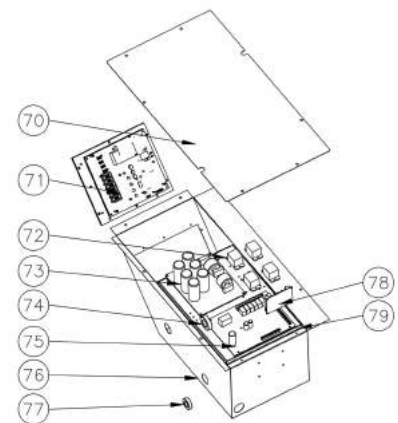
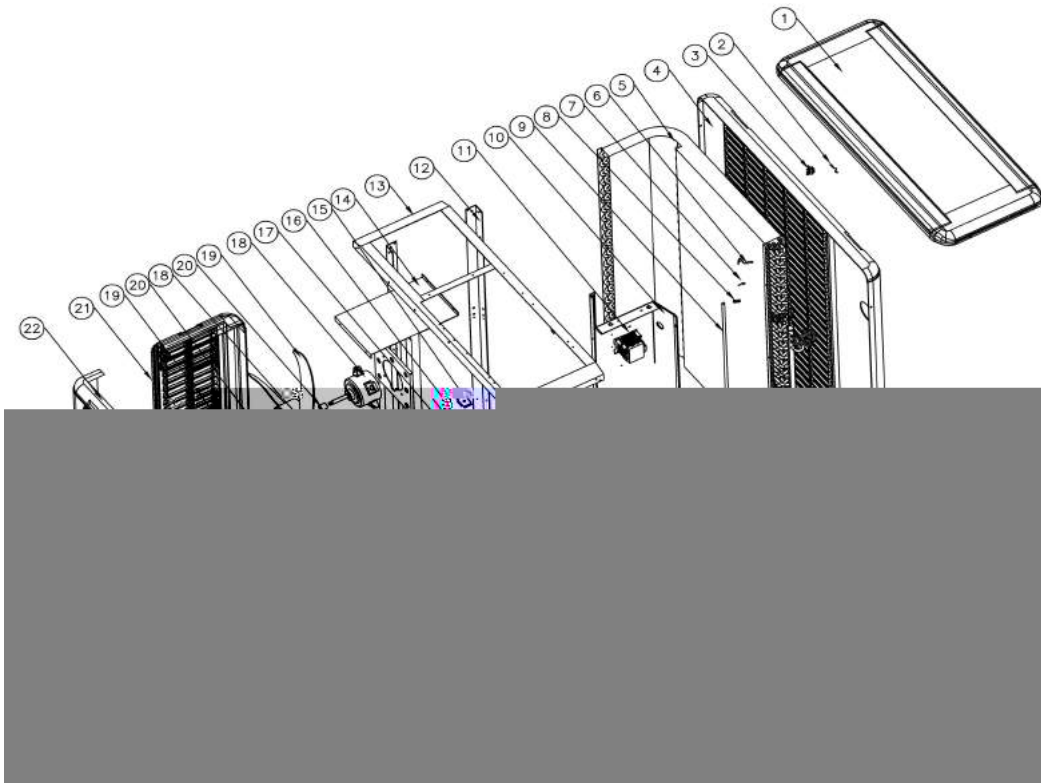

9.11 Lista de peças de reposição: 71682

NO	CÓD.FÁB.	Designação	NO	CÓD.FÁB.	Designação
1	133100001	Tampa superior	41	117020180	Controlador
2	117110020	Temperatura ambiente. sensor T5-TH1	42	113712007	Caixa do controlador à prova d 'água
3	133020010	Temperatura ambiente. clipe de sensor	43	103000208	Montagem de tubulação coletiva
4	133250003	Painel traseiro	44	136020005	Bloco de borracha
5	103000208	Evaporador	45	113020326	Tubulação de retorno de gás
6	117110004	Pipe temp. sensor T3-TH2	46	116000073	Interruptor de baixa pressão
7	113100009	Grampo	47	113060083	Válvula de 4 vias para tubulação coletiva
8	113100009	Tubo de revestimento do sensor	48	113010227	Tubo de escape
9	103000208	Tubulação de distribuição	49	113030087	Válvula de 4 vias para trocador
10	108120036	Painel de isolamento	50	121000009	Válvula de 4 vias
11	117230001	Reator	51	116000008	Interruptor de alta pressão
12	108120035	Pilar	52	117110021	Temp. De exaustão sensor T6-TH3
13	108120034	Quadro superior	53	113120020	Tanque de armazenamento de líquidos para EEV
14	108120044	Suporte do motor do ventilador	54	113130020	Filtro para tanque de armazenamento de líquidos
15	108480015	Braçadeira de cinto	55	113080055	EEV para encanamento de distribuição
16	142000079	Correia de aquecimento do evaporador	56	119000021	EEV
17	108550009	Pilar	57	120000066	Filtro
18	112000031	Motor de ventilador	58	113170028	Trocador para filtrar
19	132000015	Lâmina da ventoinha	59	112100021-1	Interruptor de fluxo de água
20	108010024	Tampa do tubo do motor DC	60	117110011	Água fora temp. sensor T2-TH5
21	133250004	Painel do lado esquerdo	61	108010025	Clipe do sensor de temperatura do permutador
22	133250001	Painel frontal	62	102040749	Trocador de calor de titânio
23	108010014	Grelha frontal	63	113900082	Conjuntos de conexão de água
24	120000091	Válvula global	64	133020012	Anel de borracha azul
25	113100008	Tubo de cobre	65	133020026	Anel de borracha na conexão de água
26	101000185	Compressor	66	117110012	Água em temp. sensor T1-TH6
27	101000185	Pés de Compressor	67	150000110	Plugue de drenagem
28	105000008	Tanque de armazenamento de líquido	68	133020011	Anel de borracha vermelha
29	142000077	Cinto de aquecimento do compressor	69	136020083	Anel de vedação
30	108550005	Bandeja base	70	108120040	Tampa da caixa elétrica
31	108550008	Lidar com pilar	71	117140016	Placa de motorista
32	108010065	Terminal Board	72	142000038	Retransmissão
33	133250002	Painel direito	73	117260001	Placa de filtro
34	115000025	Terminal de 3 lugares para eletricidade	74	117240002	Anel magnético
35	106000011	Medidor de pressão	75	117250007	PCB
36	136010004	Grampo	76	108120038	Caixa elétrica
37	108550006	Pilar	77	117240003	Anel magnético
38	115000027	Terminal de 3 lugares para bomba de água	78	117010095	Módulo Modbus
39	133250005	Tampa plástica dos blocos de terminais	79	108120039	Tábua de pesagem
40	133030011	Caixa de fiação			

9.12 Lista de peças de reposição: 71683

NO	CÓD.FÁB.	Designação	NO	CÓD.FÁB.	Designação
1	133100001	Tampa superior	41	117020180	Controlador
2	117110020	Temperatura ambiente. sensor T5-TH1	42	113712007	Caixa do controlador à prova d 'água
3	133020010	Temperatura ambiente. clipe de sensor	43	103000209	Montagem de tubulação coletiva
4	133250003	Painel traseiro	44	136020005	Bloco de borracha
5	103000209	Evaporador	45	113020389	Tubulação de retorno de gás
6	117110004	Pipe temp. sensor T3-TH2	46	116000073	Interruptor de baixa pressão
7	113100009	Grampo	47	113060083	Válvula de 4 vias para tubulação coletiva
8	113100009	Tubo de revestimento do sensor	48	113010228	Tubo de escape
9	103000209	Tubulação de distribuição	49	113030087	Válvula de 4 vias para trocador
10	108120036	Painel de isolamento	50	121000009	Válvula de 4 vias
11	117230001	Reator	51	116000008	Interruptor de alta pressão
12	108120035	Pilar	52	117110021	Temp. De exaustão sensor T6-TH3
13	108120034	Quadro superior	53	113120020	Tanque de armazenamento de líquidos para EEV
14	108120044	Suporte do motor do ventilador	54	113130020	Filtro para tanque de armazenamento de líquidos
15	108480015	Braçadeira de cinto	55	113080055	EEV para encanamento de distribuição
16	142000079	Correia de aquecimento do evaporador	56	119000042	EEV
17	108550009	Pilar	57	120000066	Filtro
18	112000031	Motor de ventilador	58	113170028	Trocador para filtrar
19	132000015	Lâmina da ventoinha	59	112100021-1	Interruptor de fluxo de água
20	108010024	Tampa do tubo do motor DC	60	117110011	Água fora temp. sensor T2-TH5
21	133250004	Painel do lado esquerdo	61	108010025	Clipe do sensor de temperatura do permutador
22	133250001	Painel frontal	62	102040754	Trocador de calor de titânio
23	108010014	Grelha frontal	63	113900082	Conjuntos de conexão de água
24	120000091	Válvula global	64	133020012	Anel de borracha azul
25	113100008	Tubo de cobre	65	133020026	Anel de borracha na conexão de água
26	101000186	Compressor	66	117110012	Água em temp. sensor T1-TH6
27	101000186	Pés de Compressor	67	150000110	Plugue de drenagem
28	105000008	Tanque de armazenamento de líquido	68	133020011	Anel de borracha vermelha
29	142000077	Cinto de aquecimento do compressor	69	136020083	Anel de vedação
30	108470069	Bandeja base	70	108120040	Tampa da caixa elétrica
31	108550008	Lidar com pilar	71	117140016	Placa de motorista
32	108010065	Terminal Board	72	142000038	Retransmissão
33	133250002	Painel direito	73	117260001	Placa de filtro
34	115000025	Terminal de 3 lugares para eletricidade	74	117240002	Anel magnético
35	106000011	Medidor de pressão	75	117250007	PCB
36	136010004	Grampo	76	108120038	Caixa elétrica
37	108550006	Pilar	77	117240003	Anel magnético
38	115000027	Terminal de 3 lugares para bomba de água	78	117010095	Módulo Modbus
39	133250005	Tampa plástica dos blocos de terminais	79	108120039	Tábua de pesagem
40	133030011	Caixa de fiação			

9.13 Modelo: 68821/68822/68823

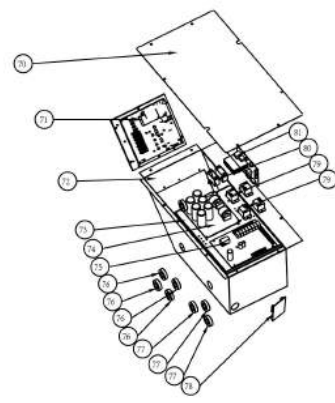
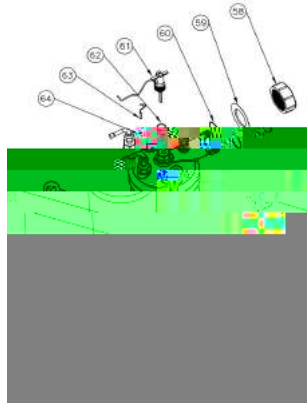
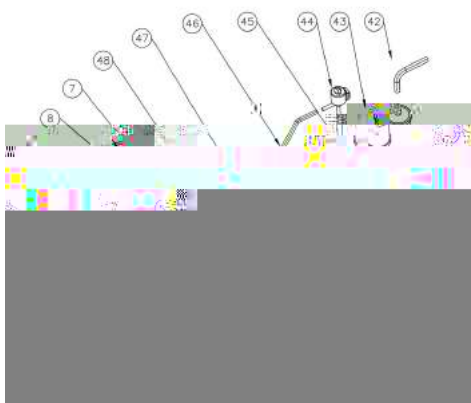
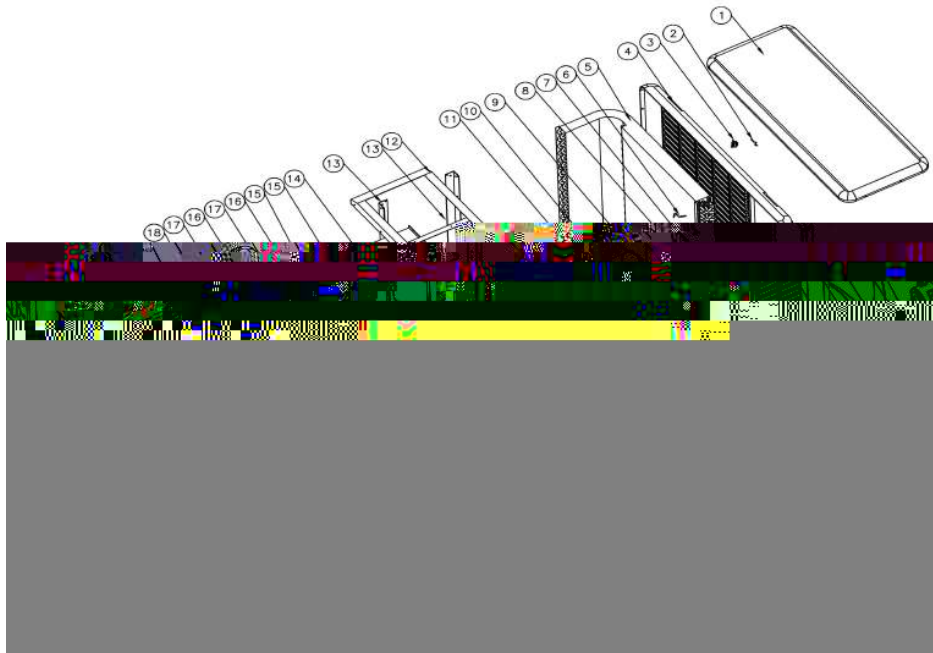

9.14 Lista de peças de reposição: 68821

NO	CÓD.FÁB.	Designação	NO	CÓD.FÁB.	Designação
1	133100001	Tampa superior	41	113050109	Tubulação coletiva
2	117110020	Temperatura ambiente. sensor T5-TH1	42	113170028	Trocador para filtrar
3	133020010	Temperatura ambiente. clipe de sensor	43	120000066	Filtro
4	133250003	painel traseiro	44	119000022	EEV
5	103000153	Evaporador	45	113080055	EEV para encanamento de distribuição
6	117110004	Pipe temp. sensor T3-TH2	46	113120020	Tanque de armazenamento de líquidos para EEV
7	113190001	Grampo	47	113030087	Válvula de 4 vias para trocador
8	113190001	Tubo de revestimento do sensor	48	117110021	Temp. De exaustão sensor T6-TH3
9	113040101	Tubulação de distribuição	49	116000008	Interruptor de alta pressão
10	108550010	Painel de isolamento	50	121000009	Válvula de 4 vias
11	117230002	Reator	51	120000023	Válvula de sucção
12	108120034	Quadro superior	52	113010158	Tubo de escape
13	108120035	Pilar	53	116000080	Interruptor de baixa pressão 0.2-0.35
14	108120037	Suporte do motor do ventilador	54	116000079	Interruptor de baixa pressão 0.1-0.3
15	112000031	Motor de ventilador	55	113020245	Tubulação de retorno de gás
16	108010024	Tampa do tubo do motor do ventilador	56	113060083	Válvula de 4 vias para tubulação coletiva
17	132000015	Lâmina da ventoíinha	57	113130015	Filtro para tanque de armazenamento de líquidos
18	133250004	Painel do lado esquerdo	58	113900082	Conjuntos de conexão de água
19	133250001	Painel frontal	59	133020011	Anel de borracha vermelha
20	108010014	Grelha frontal	60	133020026	Anel de borracha na conexão de água
21	108550009	Pilar	61	112100021	Interruptor de fluxo de água
22	108550005	Bandeja base	62	116000001	Anel de vedação
23	101000149	Compressor	63	117110011	Água fora temp. sensor T2-TH5
24	105000008	Tanque de armazenamento de líquido	64	108010025	Clipe do sensor de temperatura do permutador
25	142000077	Cinto de aquecimento do compressor	65	113900082	Conjuntos de conexão de água
26	101000149	Pés de amortecimento do compressor	66	133020012	Anel de borracha azul
27	108550008	Lidar com pilar	67	102040503	Trocador de calor de titânio
28	108010065	Terminal Board	68	117110012	Água em temp. sensor T1-TH6
29	110000008	Conexão de fio	69	150000110	Plugue de drenagem
30	108010018	Caixa de fiação	70	108120040	Tampa da caixa elétrica
31	133250002	Painel direito	71	117140003	Placa de motorista
32	115000025	Terminal de 3 lugares para eletricidade	72	108120038	Caixa elétrica
33	110800001	Medidor de pressão	73	108120039	Tábua de pesagem
34	136010004	Grampo	74	117260002	Placa de filtro
35	108550006	Pilar	75	117250001 -V1.5	PCB
36	115000027	Terminal de 3 lugares para bomba de	76	117240002	anel magnético
37	133250005	Tampa plástica dos blocos de terminais	77	117240003	anel magnético
38	113712007	Caixa do controlador à prova d 'água	78	117010095	Módulo Modbus
39	117020150	Controlador	79	142000038	Retransmissão
40	136020005	Bloco de borracha	80	N/A	N/A
			81	117140006	Placa de acionamento do motor do ventilador

9.15 Lista de peças de reposição: 68822

NO	CÓD.FÁB.	Designação	NO	CÓD.FÁB.	Designação
1	133100001	Tampa superior	41	113050110	Tubulação coletiva
2	117110020	Temperatura ambiente. sensor T5-TH1	42	113170028	Trocador para filtrar
3	133020010	Temperatura ambiente. clipe de sensor	43	120000066	Filtro
4	133250003	Painel traseiro	44	119000022	EEV
5	103000154	Evaporador	45	113080055	EEV para encanamento de distribuição
6	117110004	Sensor de temperatura da tubulação T3-TH2	46	113120020	Tanque de armazenamento de líquidos para EEV
7	113190001	Grampo	47	113030087	Válvula de 4 vias para trocador
8	113190001	Tubo de revestimento do sensor	48	117110021	Temp. De exaustão sensor T6-TH3
9	113040102	Tubulação de distribuição	49	116000008	Interruptor de alta pressão
10	108550010	Painel de isolamento	50	121000009	Válvula de 4 vias
11	117230004	Reator	51	120000023	Válvula de sucção
12	108120034	Quadro superior	52	113010158	Tubo de escape
13	108120035	Pilar	53	116000080	Interruptor de baixa pressão 0.2-0.35
14	108120037	Suporte do motor do ventilador	54	116000079	Interruptor de baixa pressão 0.1-0.3
15	112000031	Motor de ventilador	55	113020245	Tubulação de retorno de gás
16	108010024	Tampa do tubo do motor do ventilador	56	113060083	Válvula de 4 vias para tubulação coletiva
17	132000015	Lâmina da ventoinha	57	113130015	Filtro para tanque de armazenamento de líquidos
18	133250004	Painel do lado esquerdo	58	113900082	Conjuntos de conexão de água
19	133250001	Painel frontal	59	133020011	Anel de borracha vermelha
20	108010014	Grelha frontal	60	133020026	Anel de borracha na conexão de água
21	108550009	Pilar	61	112100021-1	Interruptor de fluxo de água
22	108550005	Bandeja base	62	116000001-2	Anel de vedação
23	101000122	Compressor	63	117110011	Água fora temp. sensor T2-TH5
24	105000008	Tanque de armazenamento de líquido	64	108010025	Clipe do sensor de temperatura do permutador
25	142000077	Cinto de aquecimento do compressor	65	113900082	Conjuntos de conexão de água
26	101000122	Pés de amortecimento do compressor	66	133020012	Anel de borracha azul
27	108550008	Lidar com pilar	67	102040502	Trocador de calor de titânio
28	108010065	Terminal Board	68	117110012	Água em temp. sensor T1-TH6
29	110000008	Conexão de fio	69	150000110	Plugue de drenagem
30	108010018	Caixa de fiação	70	108120040	Tampa da caixa elétrica
31	133250002	Painel direito	71	117140002	Placa de motorista
32	115000025	Terminal de 3 lugares para eletricidade	72	108120038	Caixa elétrica
33	110800001	Medidor de pressão	73	108120039	Tábua de pesagem
34	136010004	Grampo	74	117260001	Placa de filtro
35	108550006	Pilar	75	117250001-V1.5	PCB
36	115000027	Terminal de 3 lugares para bomba de água	76	117240002	Anel magnético
37	133250005	Tampa plástica dos blocos de	77	117240003	Anel magnético
38	113712007	Caixa do controlador à prova d'água	78	117010095	Módulo Modbus
39	117020150	Controlador	79	142000038	Retransmissão
40	136020005	Bloco de borracha	80	N/A	N/A
			81	N/A	N/A

9.16 Lista de peças de reposição: 68823

NO	CÓD.FÁB.	Designação	NO	CÓD.FÁB.	Designação
1	133100001	Tampa superior	41	113050110	Tubulação coletiva
2	117110020	Temperatura ambiente. sensor T5-TH1	42	113170028	Trocador para filtrar
3	133020010	Temperatura ambiente. clipe de sensor	43	120000066	Filtro
4	133250003	painel traseiro	44	119000022	EEV
5	103000154	Evaporador	45	113080055	EEV para encanamento de distribuição
6	117110004	Pipe temp. sensor T3-TH2	46	113120020	Tanque de armazenamento de líquidos para EEV
7	113190001	Grampo	47	113030087	Válvula de 4 vias para trocador
8	113190001	Tubo de revestimento do sensor	48	117110021	Temp. De exaustão sensor T6-TH3
9	113040102	Tubulação de distribuição	49	116000008	Interruptor de alta pressão
10	108550010	Painel de isolamento	50	121000009	Válvula de 4 vias
11	117230002	Reator	51	120000023	Válvula de sucção
12	108120034	Quadro superior	52	113010158	Tubo de escape
13	108120035	Pilar	53	116000080	Interruptor de baixa pressão 0.2-0.35
14	108120037	Suporte do motor do ventilador	54	116000079	Interruptor de baixa pressão 0.1-0.3
15	112000031	Motor de ventilador	55	113020245	Tubulação de retorno de gás
16	108010024	Tampa do tubo do motor do ventilador	56	113060083	Válvula de 4 vias para tubulação coletiva
17	132000015	Lâmina da ventoinha	57	113130015	Filtro para tanque de armazenamento de líquidos
18	133250004	Painel do lado esquerdo	58	113900082	Conjuntos de conexão de água
19	133250001	Painel frontal	59	133020011	Anel de borracha vermelha
20	108010014	Grelha frontal	60	133020026	Anel de borracha na conexão de água
21	108550009	Pilar	61	112100021-1	Interruptor de fluxo de água
22	108550005	Bandeja base	62	116000001-2	Anel de vedação
23	101000149	Compressor	63	117110011	Água fora temp. sensor T2-TH5
24	105000008	Tanque de armazenamento de líquido	64	108010025	Clipe do sensor de temperatura do permutador
25	142000077	Cinto de aquecimento do compressor	65	113900082	Conjuntos de conexão de água
26	101000149	Pés de amortecimento do compressor	66	133020012	Anel de borracha azul
27	108550008	Lidar com pilar	67	102040502	Trocador de calor de titânio
28	108010065	Terminal Board	68	117110012	Água em temp. sensor T1-TH6
29	110000008	Conexão de fio	69	150000110	Plugue de drenagem
30	108010018	Caixa de fiação	70	108120040	Tampa da caixa elétrica
31	133250002	Painel direito	71	117140003	Placa de motorista
32	115000006	Terminal de 3 lugares para eletricidade	72	108120038	Caixa elétrica
33	110800001	Medidor de pressão	73	108120039	Tábua de pesagem
34	136010004	Grampo	74	117260002	Placa de filtro
35	108550006	Pilar	75	117250001-V 1.5	PCB
36	115000027	Terminal de 3 lugares para bomba de	76	117240002	anel magnético
37	133250005	Tampa plástica dos blocos de terminais	77	117240003	anel magnético
38	113712007	Caixa do controlador à prova d'água	78	117010095	Módulo Modbus
39	117020150	Controlador	79	142000038	Retransmissão
40	136020005	Bloco de borracha	80	N/A	N/A
			81	117140006	Placa de acionamento do motor do ventilador

9.16 Manutenção

- (1) Verificar o sistema de abastecimento de água regularmente para evitar o ar que entra no sistema e a ocorrência de baixo fluxo de água, porque iria reduzir o desempenho e a confiabilidade da unidade HP.
- (2) Limpar regularmente a piscina e o sistema de filtração para evitar danos à unidade, causados pela acumulação de sujidade que conduzem ao entupimento do filtro.
- (3) Descarregar a água do fundo da bomba de água, se a unidade HP parar de funcionar durante um longo período de tempo (especialmente durante a época de Inverno).
- (4) Verificar se a unidade está cheia de água antes de começar a funcionar novamente.
- (5) Depois de acondicionar a unidade para a estação de inverno, é recomendado cobrir a bomba de calor com uma cobertura especial de inverno.
- (6) Quando a unidade está em funcionamento existe sempre uma pequena descarga de água pela parte inferior.
- (7) A acção de enchimento de gás deve ser realizada por profissional com licença de operação R32.
- (8) Por favor, preencha o gás R32 da válvula globo dentro da máquina.



EN GUARANTEE CERTIFICATE 1

GENERAL TERMS

1.1 In accordance with these provisions, the seller guarantees that the product corresponding to this guarantee (“the Product”) is in perfect condition at the time of delivery.

1.2 The Guarantee Term for the Product is two (2) years from the time it is delivered to the purchaser.

1.3 In the event of any defect in the Product that is notified by the purchaser to the seller during the Guarantee Term, the seller will be obliged to repair or replace the Product, at his own cost and wherever he deems suitable, unless this is impossible or unreasonable.

1.4 If it is not possible to repair or replace the Product, the purchaser may ask for a proportional reduction in the price or, if the defect is sufficiently significant, the termination of the sales contract.

1.5 The replaced or repaired parts under this guarantee, will not extend the guarantee period of the original Product, but will have a separate guarantee.

1.6 In order for this guarantee to come into effect, the purchaser must provide proof of the date of purchase and delivery of the Product.

1.7 If, after six months from the delivery of the Product to the purchaser, he notifies a defect in the Product, the purchaser must provide proof of the origin and existence of the alleged defect.

1.8 This Guarantee Certificate is issued without prejudice to the rights corresponding to consumers under national regulations.

2 INDIVIDUAL TERMS

2.1 This guarantee covers the products referred to in this manual.

2.2 This Guarantee Certificate will only be applicable in European Union countries.

2.3 For this guarantee to be effective, the purchaser must strictly follow the Manufacturer’s instructions included in the documentation provided with the Product, in cases where it is applicable according to the range and model of the Product.

2.4 When a time schedule is specified for the replacement, maintenance or cleaning of certain parts or components of the Product, the guarantee will only be valid if this time schedule has been followed.

3 LIMITATIONS

3.1 This guarantee will only be applicable to sales made to consumers, understanding by “consumer”, a person who purchases the Product for purposes not related to his professional activities.

3.2 The normal wear resulting from using the product is not guaranteed. With respect to expendable or consumable parts, components and/or materials, such as batteries, light bulbs, etc. the stipulations in the documentation provided with the Product, will apply.

3.3 The guarantee does not cover those cases when the Product; (I) has been handled incorrectly; (II) has been repaired, serviced or handled by non- authorised people or (III) has been repaired or serviced not using original parts. In cases where the defect of the Product is a result of incorrect installation or start-up, this guarantee will only apply when said installation or start-up is included in the sales contract of the Product and has been conducted by the seller or under his responsibility.

ES - CERTIFICADO DE GARANTÍA

1 ASPECTOS GENERALES

1.1 De acuerdo con estas disposiciones, el vendedor garantiza que el producto correspondiente a esta garantía ("el Producto") no presenta ninguna falta de conformidad en el momento de su entrega.

1.2 El Período de Garantía para el Producto es de dos (2) años y se calculará desde el momento de su entrega al comprador.

1.3 Si se produjera una falta de conformidad del

vendeur o bajo su responsabilidad.

FR - CERTIFICAT DE GARANTIE

1 ASPECTS GÉNÉRAUX

1.1 Conformément à ces dispositions, le vendeur garantit que le produit correspondant à cette garantie ("le Produit") ne présente aucun défaut de conformité à la date de sa livraison.

1.2 La Période de Garantie pour le Produit est de deux (2) ans et elle sera calculée à partir du moment de sa remise à l'acheteur.

1.3 S'il se produisait un défaut de conformité du Produit et si l'acheteur le notifiait au vendeur pendant la Période de Garantie, le vendeur devrait réparer ou remplacer le Produit à ses propres frais à l'endroit qu'il jugerait opportun, à moins que cela soit impossible ou disproportionné.

1.4 Lorsque le Produit ne pourra être ni réparé ni remplacé, l'acheteur pourra demander une réduction proportionnelle du prix ou, si le défaut de conformité est suffisamment important, la résolution du contrat de vente.

1.5 Les parties remplacées ou réparées en vertu de cette garantie n'élargiront pas le délai de la garantie du Produit original, celles-ci étant cependant couvertes par leur propre garantie.

1.6 Pour l'effectivité de la présente garantie, l'acheteur devra justifier la date d'acquisition et de remise du Produit.

1.7 Quand plus de six mois se seront écoulés depuis la remise du Produit à l'acheteur et que ce dernier alléguera un défaut de conformité de ce Produit, l'acheteur devra justifier l'origine et l'existence du défaut allégué.

1.8 Le présent Certificat de Garantie ne limite pas, ni préjuge les droits correspondant aux consommateurs en vertu des normes nationales de nature impérative.

2 CONDITIONS PARTICULIÈRES

2.1 La présente garantie couvre les produits auxquels ce manuel fait référence.

2.2 Le présent Certificat de Garantie ne sera applicable que dans les pays de l'Union européenne.

2.3 En vue de l'efficacité de cette garantie, l'acheteur devra suivre strictement les indications du Fabricant comprises dans la documentation qui est jointe au Produit, quand celle-ci sera applicable selon la gamme et le modèle du Produit.

2.4 Quand un calendrier sera spécifié pour le remplacement, la maintenance ou le nettoyage de certaines pièces ou de certains composants du Produit, la garantie sera valable uniquement lorsque ledit calendrier aura été suivi correctement.

3 LIMITATIONS

3.1 La présente garantie ne sera applicable que dans les ventes réalisées aux consommateurs, considérant comme "consommateur", toute personne qui achète le Produit à des fins qui n'entrent pas dans le cadre de son activité professionnelle.

3.2 Aucune garantie n'est concédée quant à l'usure normale due à l'utilisation du produit. En ce qui concerne les pièces, composants et/ou matériels fongibles ou consommables comme les piles, les ampoules, etc., il faudra respecter, le cas échéant, ce qui est stipulé dans la documentation qui est jointe au Produit.

3.3 La garantie ne couvre pas les cas où le Produit : (I) a fait l'objet d'un traitement incorrect ; (II) a été réparé, entretenu ou manipulé par une personne non autorisée ou (III) a été réparé ou entretenu avec des pièces n'étant pas d'origine. Quand le défaut de conformité du

Produit sera la conséquence d'une installation ou d'une mise en marche incorrectes, la présente garantie répondra uniquement lorsque ladite installation ou ladite mise en marche sera incluse dans le contrat d'achat et de vente du Produit et aura été réalisée par le vendeur ou sous sa responsabilité.

DE - GARANTIEZERTIFIKAT

1 ALLGEMEINE GESICHTSPUNKTE

1.1 In Übereinstimmung mit diesen Verfügungen garantiert der Verkäufer, dass das Produkt dieser Garantie ("das Produkt") entspricht und dass es im Moment der Übergabe in allen Punkten mit den Anforderungen übereinstimmt.

1.2 Der Garantiezeitraum für das Produkt beträgt zwei (2) Jahre und wird ab dem Augenblick der Lieferung an den Käufer gerechnet.

1.3 Falls ein Mangel am Produkt auftritt und der Käufer den Verkäufer innerhalb des Garantiezeitraums darüber unterrichtet, muss der Verkäufer das Produkt auf eigene Kosten dort reparieren oder ersetzen, wo es für ihn am günstigsten ist, es sei denn, dies ist unmöglich oder unverhältnismäßig.

1.4 Wenn das Produkt weder repariert noch ersetzt werden kann, kann der Käufer einen angemessenen Preisnachlass beantragen, oder, falls es sich um einen größeren Mangel handelt, die Auflösung des Kaufvertrages.

1.5 Die Teile, die aufgrund dieser Garantie ersetzt oder repariert werden, verlängern den Garantiezeitraum für das Originalprodukt nicht. Jedoch existiert für diese Teile eine eigene Garantie.

1.6 Um die vorliegende Garantie wirksam werden zu lassen, muss der Käufer das Kaufdatum und das Lieferdatum des Produktes belegen.

1.7 Nach Ablauf von sechs Monaten ab Lieferung des Produktes an den Käufer muss, im Falle eines Mangels, der Käufer den Ursprung und das Vorhandensein des angegebenen Mangels belegen.

1.8 Das vorliegende Garantiezertifikat schränkt die Rechte, die der Verbraucher aufgrund der herrschenden, nationalen Gesetzgebung hat, nicht ein.

2 SONDERBEDINGUNGEN

2.1 Die vorliegende Garantie gilt für die Produkte, auf die sich dieses Handbuch bezieht.

2.2 Das vorliegende Garantiezertifikat ist nur in den Ländern der Europäischen Gemeinschaft anwendbar.

2.3 Diese Garantie gilt nur, wenn der Käufer alle Anweisungen des Herstellers, die in der produktbegleitenden Dokumentation enthalten und für die jeweilige Produktlinie und Modell anwendbar ist, streng einhält.

2.4 Wenn ein Zeitplan für den Austausch von Teilen, die Instandhaltung und Reinigung bestimmter Teile oder Produktkomponenten aufgestellt wurde, gilt die Garantie nur dann, wenn dieser Zeitplan korrekt eingehalten wurde.

3 EINSCHRÄNKUNGEN

3.1 Die vorliegende Garantie ist nur auf Verkäufe an Verbraucher anwendbar. "Verbraucher" sind alle Personen, die dieses Produkt zu privaten Zwecken erwerben.

3.2 Es wird keine Garantie für die normale Abnutzung durch den Gebrauch des Produktes gewährt. Informationen über Teile, Komponenten und/oder verschleißbare Materialien oder Verbrauchsgüter oder Batterien, Glühbirnen etc. finden Sie in der Dokumentation, die das jeweilige Produkt begleitet.

3.3 In folgenden Fällen gilt die Garantie nicht: (I) Das Produkt wurde nicht korrekt benutzt;

(II) das Produkt wurde von nicht autorisierten Personen repariert, instandgehalten oder bedient oder
(III) das Produkt wurde mit nicht originalen Ersatzteilen repariert oder instandgehalten. Wenn der Mangel auf eine falsche Installation oder Inbetriebnahme zurückzuführen ist, gilt die vorliegende Garantie nur, wenn diese Installation oder Inbetriebnahme in den Kaufvertrag des Produktes eingeschlossen war, und von dem Verkäufer oder auf dessen Verantwortung durchgeführt wurde.

IT - CERTIFICATO DI GARANZIA 1

ASPETTI GENERALI

1.1 Ai sensi delle seguenti disposizioni, il venditore garantisce che il prodotto corrispondente a questa garanzia ("il Prodotto") non presenta alcun difetto di conformità al momento della sua consegna.

1.2 Il Periodo di Garanzia per il Prodotto è di due (2) anni a decorrere dal momento della consegna dello stesso all'acquirente.

1.3 Nel caso in cui si venisse a produrre un difetto di conformità del Prodotto e l'acquirente lo notificasse al venditore entro il Periodo di Garanzia, il venditore dovrà riparare o sostituire il Prodotto a sue spese nel luogo che consideri opportuno, salvo che ciò risulti impossibile o sproporzionato.

1.4 Qualora non fosse possibile riparare o sostituire il Prodotto, l'acquirente potrà richiedere una riduzione proporzionale del prezzo o, nel caso in cui il difetto di conformità fosse sufficientemente importante, lo scioglimento del contratto di vendita.

1.5 Le parti sostituite o riparate in virtù della presente garanzia non rappresenteranno un prolungamento della scadenza della garanzia del Prodotto originale, quantunque disporranno di una loro propria garanzia.

1.6 Affinché la presente possa essere valida, l'acquirente dovrà attestare la data di acquisto e consegna di del Prodotto.

1.7 Una volta trascorsi più di sei mesi dalla consegna del Prodotto all'acquirente, qualora quest'ultimo dichiari un difetto di conformità del medesimo, l'acquirente dovrà attestare l'origine e l'esistenza del difetto dichiarato.

1.8 Il presente Certificato di Garanzia non limita o preclude i diritti che corrispondano ai consumatori in virtù delle norme nazionali di carattere imperativo.

2 CONDIZIONI PARTICOLARI

2.1 La presente garanzia copre i prodotti al quali si riferisce questo manuale.

2.2 Il presente Certificato di Garanzia avrà vigore unicamente nell'ambito dei paesi dell'Unione Europea.

2.3 Per la validità di questa garanzia, l'acquirente dovrà rispettare in maniera rigorosa le indicazioni del Fabbricante indicate nella documentazione che viene allegata al Prodotto, quando questa risulti applicabile secondo la gamma e il modello del Prodotto.

2.4 Nel caso in cui venga specificato un calendario per la sostituzione, la manutenzione o la pulizia di determinati pezzi o componenti del Prodotto, la garanzia sarà valida solo quando qualora detto calendario sia stato rispettato in maniera corretta.

3 LIMITAZIONI

3.1 La presente garanzia sarà valida unicamente per le vendite realizzate a consumatori, laddove per "consumatori" s'intende quella persona che acquista il Prodotto con scopi che non rientrano nell'ambito della sua attività professionale.

3.2 Non viene concessa alcuna garanzia nei riguardi del normale consumo per uso del

NL - GARANTIECERTIFIKAAT

1 ALGEMENE ASPEKTEN

1.1 In overeenkomst met de voorliggende bepalingen wordt door de verkoper gegarandeerd dat het produkt verkocht onder deze garantie ("het Produkt") geen enkel defect vertoont op het moment van levering.

1.2 De Garantieperiode voor het Produkt bedraagt twee (2) jaar en is geldig vanaf het moment dat het Produkt aan de

Gf

3 BEPERKINGEN

3.1 De huidige garantie is uitsluitend geldig bij verkoop aan gebruikers, waarbij onder “gebruiker” verstaan wordt een persoon die het Produkt aanschaft met een doel dat niet binnen het gebied van zijn professionele activiteiten valt.

3.2 Er bestaat geen garantie in verband met normale slijtage bij gebruik van het Produkt. Wat betreft de delen, componenten en/of vervangbare of verbruiksmaterialen zoals batterijen, gloeilampen, enz. zal men zich moeten richten naar hetgeen in de documenten staat die het Produkt vergezellen.

3.3 De garantie dekt niet de gevallen waarbij het Produkt (i) onderhevig is geweest aan ongepast gebruik, (ii) gerepareerd, onderhouden of gemanipuleerd is door een persoon die daarvoor geen toestemming heeft, of (iii) gerepareerd of onderhouden is met niet oorspronkelijke onderdelen. Indien het defect van het Produkt het gevolg is van een incorrecte installering of ingebruikneming, dan is deze garantie slechts van toepassing indien de installering of ingebruikneming in kwestie in het contract van koop en verkoop van het produkt opgenomen is en door de verkoper of onder diens verantwoordelijkheid uitgevoerd is.

PT - CERTIFICADO DE GARANTIA

1 CONDIÇÕES GERAIS

1.1 De acordo com estas disposições, o vendedor garante que, no momento da entrega, o produto correspondente a esta garantia (“o Produto”) não apresenta nenhum tipo de falta de conformidade.

1.2 O Período de Garantia para o Produto é de dois (2) anos, contados a partir da data de entrega ao comprador.

1.3 Se, durante o período de garantia, o comprador notificar ao vendedor alguma falta de conformidade do Produto, o vendedor deverá reparar ou substituir o Produto por sua conta no lugar onde considerar conveniente, salvo que isso seja impossível ou desmesurado.

1.4 Quando não for possível reparar ou substituir o Produto, o comprador poderá solicitar uma redução proporcional do preço ou, se a falta de conformidade for o suficientemente grave, a rescisão do contrato de venda.

1.5 As partes substituídas ou reparadas em virtude desta garantia não ampliarão o período de garantia do Produto original, mas disporão da sua própria garantia.

1.6 Para que a presente garantia tenha efeito, o comprador deverá apresentar o comprovante da data de compra e de entrega do Produto.

1.7 Se o comprador alegar uma falta de conformidade do Produto, passados mais de seis meses da data de entrega do mesmo, deverá demonstrar a origem e a existência do defeito alegado.

1.8 O presente Certificado de Garantia não limita nem afecta os direitos dos consumidores derivados das normas nacionais de carácter imperativo.

2 CONDIÇÕES PARTICULARES

2.1 A presente garantia cobre os produtos descritos neste manual.

2.2 O presente Certificado de Garantia só será válido nos países da União Europeia.

2.3 Para a eficácia desta garantia, o comprador deverá seguir rigorosamente as indicações do Fabricante contidas na documentação fornecida com o Produto, quando a mesma for aplicável em função da gama e do modelo do Produto.

2.4 No caso de se estabelecer um calendário para a substituição, manutenção ou limpeza de determinadas peças ou componentes do Produto, a garantia só será válida se o citado

calendário tiver sido cumprido rigorosamente.

3 LIMITAÇÕES

3.1 A presente garantia só será válida para as vendas realizadas a consumidores, entendendo-se por “consumidor” a pessoa que comprar o Produto com fins não abrangidos no âmbito da sua actividade profissional.

3.2 A garantia não cobre o desgaste normal derivado do uso do produto. Em relação às peças, componentes e/ou materiais fungíveis ou consumíveis como pilhas, lâmpadas, etc., terá efeito o disposto na documentação fornecida com o Produto, em cada caso.

3.3 Esta garantia não abrange as seguintes situações: (I) Se o Produto tiver sido objecto de um uso incorrecto; (II) tiver sido reparado, sofrido manutenção ou manipulado por pessoas não autorizadas ou (III) tiver sido reparado ou as suas peças substituídas por peças não originais. Quando a falta de conformidade do Produto for consequência de uma instalação ou colocação em funcionamento incorrecta, a presente garantia só será válida se a referida instalação ou colocação em funcionamento estiver incluída no contrato de compra-venda do Produto e tiver sido realizada pelo vendedor ou sob sua responsabilidade.



EN - CROSSED-OUT WASTE CONTAINER

1.1 In order to reduce the amount of waste of electric and electronic apparatus, to reduce the danger of components, to encourage the reuse of apparatus, to assess waste and to set up a suitable waste treatment system, with the aim of improving the efficiency of environmental protection, a set of rules has been established applicable to the manufacture of the product and other rules regarding the correct environmental treatment when these products become waste.

1.2 It is also intended to improve the environmental practices of all agents involved in electrical and electronic goods, including manufacturers, distributors, users and particularly those directly involved in the treatment of waste derived from these apparatus.

1.3 From 13th August 2005, there are two ways of disposing of this apparatus:

1.4 If you purchase a new equivalent apparatus or which has the same functions as the one you wish to dispose of, you can hand it over, free of charge, to the distributor when making your purchase, or

1.5 You can take it to local collection points.

1.6 We shall cover waste treatment costs.

1.7 The apparatus are labelled with a symbol of a “crossed-out waste container”. This symbol means that the apparatus is subject to selected waste collection, different from general waste collection.

1.8 Our products are designed and manufactured with top-quality, environmental-friendly materials and components, which can be reused and recycled. In spite of this, several parts of this product are not biodegradable and therefore it should not be left in the environment. For the correct recycling of this product, please completely detach the electrical motor from the rest of the filtration equipment.



ES - CONTENEDOR DE BASURA CON RUEDAS TACHADO

1.1 Con objeto de reducir la cantidad de residuos de aparatos eléctricos y electrónicos, la peligrosidad de los componentes, fomentar la reutilización de los aparatos, la valorización de sus residuos y determinar una gestión adecuada tratando de mejorar la eficacia de la protección ambiental, se establecen una serie de normas aplicables a la fabricación del producto y otras relativas a la correcta gestión ambiental cuando se conviertan en residuo.

1.2 Así mismo, se pretende mejorar el comportamiento ambiental de todos los agentes que intervienen en el ciclo de vida de los aparatos eléctricos y electrónicos, como son los productores, los distribuidores, los usuarios y en particular, el de aquellos agentes directamente implicados en la gestión de los residuos derivados de estos aparatos.

1.3 A partir del 13 Agosto de 2005 cuando usted quiera desechar este aparato, tiene dos posibles sistemas de devolución:

1.4 Si adquiere uno nuevo que sea de tipo equivalente o realice las mismas funciones que el que desecha, podrá entregarlo, sin coste, en el acto de la compra al distribuidor.

1.5 Podrá llevarlo al sitio que destinen las diferentes entidades locales.

1.6 Nosotros nos haremos cargo de los costes de gestión.

1.7 Los aparatos van etiquetados con el símbolo de un “contenedor de basura con ruedas tachado”, este símbolo es indicativo de la necesaria recogida selectiva y diferenciada del resto de las basuras urbanas.

1.8 Nuestros productos están diseñados y fabricados con materiales y componentes de alta calidad, respetuosos con el medio ambiente, que pueden ser reutilizables y reciclados. Aun así, las diferentes partes que componen este producto no son biodegradables, por lo que no se deben abandonar en el medio ambiente. Se debe de reciclar por separado, para ello separar el motor eléctrico del resto del equipo de filtración.



FR - POUHELLE À ORDURES SUR ROULETTES BARRÉE

1.1 Afin de réduire la quantité de déchets d'appareils électriques et électroniques, afin d'éviter le danger de leurs composants, d'encourager la réutilisation des appareils ainsi que la valorisation de leurs déchets, et de déterminer une gestion appropriée de ceux-ci, en essayant d'améliorer l'efficacité de la protection environnementale, ont été établies de nombreuses normes applicables à la fabrication du produit, et d'autres relatives à la gestion environnementale correcte lorsque ces appareils sont hors service.

1.2 De même, on prétend améliorer le comportement environnemental de toutes les personnes qui interviennent dans le cycle de vie des appareils électriques et électroniques, tels que les producteurs, les distributeurs, les utilisateurs et, en particulier, les intervenants directement impliqués dans la gestion des déchets dérivés de ces appareils.

1.3 À partir du 13 août 2005, quand vous souhaitez vous débarrasser de votre appareil usagé, vous avez deux façons de vous en débarrasser :

1.4 Si vous achetez un nouvel appareil qui est plus ou moins du même genre ou qui réalise les mêmes fonctions que votre appareil usagé, vous pourrez le remettre au distributeur, sans aucun frais à votre charge, au moment de l'achat.

1.5 Ou bien vous pourrez le déposer à l'endroit destiné à cette fin par les différents organismes locaux.

1.6 Les frais de gestion seront à notre charge.

1.7 Les appareils portent une étiquette sur laquelle figure le symbole d'une "poubelle à ordures sur roulettes barrée". Ce symbole indique la nécessité d'une collecte sélective et triée du reste des déchets urbains.

1.8 Nos produits sont conçus et fabriqués avec des matériaux et des composants de haute qualité, respectueux de l'environnement, qui sont réutilisables et recyclables. Malgré tout, les différentes parties qui composent cet article ne sont pas biodégradables ; c'est pourquoi, il ne faut pas les mettre au rebut en les jetant dans l'environnement.



DE - DURCHGESTRICHENEN ABFALLCONTAINERS MIT RÄDERN

1.1 Um die Menge an Abfällen, die aus elektrischen und elektronischen Geräten bestehen,

Produkt verwendet werden, die auf die korrekte und umweltbewusste Entsorgung ziehen und Produkte zu Fall kommen.

1.3 Insofern es sich um umweltfreundliche Produkte verbessert werden, die mit den elektrischen und elektronischen Apparaten während deren gesamtem Nutzungszyklus in Kontakt kommen, das sind zum Beispiel die Hersteller, die Vertrieber, die Benutzer und insbesondere diejenigen, die direkt mit der Entsorgung der Rückstände zu tun haben, die durch diese Apparate entstehen.

1.4 Ab dem 13. August 2005 gibt es zwei Möglichkeiten für die Rückgabe, wenn Sie diesen Apparat entsorgen möchten:

1.5 Falls Sie einen neuen, ähnlichen Apparat oder einen, der den gleichen Funktionen dient, erwerben, können Sie das alte Gerät kostenlos beim Kauf des neuen Gerätes an Ihren Verkäufer zurückgeben.

1.6 Oder Sie können den Apparat zu einer der öffentlichen Annahmestellen für diese Art von Sondermüll bringen.

1.7 Wir übernehmen die Kosten der Entsorgung.

1.8 Die Apparate sind mit einem Etikett mit dem Symbol eines „durchgestrichenen Abfallcontainers mit Rädern“ versehen. Dieses Symbol gibt an, dass es sich um Sondermüll handelt, und nicht um gewöhnlichen städtischen Müll.

1.9 Unsere Produkte bestehen aus Materialien und Komponenten hoher Qualität, die umweltfreundlich sind und wieder benutzt oder recycelt werden können. Dennoch sind die verschiedenen Teile, aus denen dieses Produkt besteht, nicht biologisch abbaubar, deshalb können sie nicht einfach weggeworfen werden. Um dieses Produkt korrekt zu recycling, bitte den elektrischen Motor von der Filteranlage zerlegen.

IT - CONTENITORE DELLA SPAZZATURA, SBARRATO

1.1 Allo scopo di ridurre la quantità di residui di apparati elettrici ed elettronici, la pericolosità dei componenti, promuovere il riutilizzo degli apparecchi, la valutazione dei loro residui e determinare una gestione adeguata cercando di migliorare l'efficacia della protezione ambientale, si stabiliscono una serie di norme applicabili alla fabbricazione del prodotto ed altre relative alla corretta gestione ambientale quando si trasformano in residui.

1.2 Allo stesso modo, si cerca di migliorare il comportamento ambientale di tutti gli agenti che intervengono nel ciclo vitale degli apparecchi elettrici ed elettronici, come i produttori, i distributori, i consumatori e, in particolare, il comportamento di quegli agenti direttamente implicati nella gestione dei residui derivati da questi apparecchi.

1.3 A partire dal 13 agosto del 2005, quando vorrai disfarti di questo apparecchio, avrà due possibili sistemi di rottamazione a sua disposizione:

1.4 Se acquisti un apparecchio uoi o

1.8 I nostri prodotti sono progettati e fabbricati con materiali e componenti di elevata qualità, che rispettano l'ambiente, che possono essere riutilizzati e riciclati. Pur in questo caso, le varie parti che compongono questo prodotto non sono biodegradabili, per cui non devono essere abbandonate nell'ambiente. Per il riciclaggio corretto di questo prodotto, stacchi il motore dal resto dell'apparecchio di filtrazione.



NL - EEN DOORGESTREEPTE AFVALCONTAINER MET WIELEN

1.1 Teneinde het afval afkomstig van elektrische en elektronische apparaten en de schadelijke effecten van de diverse onderdelen te verminderen, het hergebruik van apparaten en de evaluatie van de effecten van het afval te bevorderen, en een gepast beheer en de bescherming van het milieu te bevorderen, zijn een aantal regels vastgesteld aangaande de fabricage van dit product alsmede de correcte milieubewuste verwerking van het apparaat wanneer het eenmaal wordt afgevoerd.

1.2 Bovendien is het de bedoeling de milieubewuste verwerking door alle agenten die bij de gebruikscyclus van de elektrische en elektronische apparaten betrokken zijn te verbeteren, zoals bijvoorbeeld leveranciers, distributeurs, gebruikers, en in het bijzonder de agenten die direct betrokken zijn bij de verwerking van het afval afkomstig van deze apparaten.

1.3 Met ingang van 13 augustus 2005 kunt u uit twee mogelijkheden kiezen wanneer u dit apparaat wilt weggooien:

1.4 Wanneer u een nieuw exemplaar aanschaft van een vergelijkbaar type of dat dezelfde functies verricht als het weg te gooien exemplaar, kunt u het oude exemplaar zonder kosten bij de distributeur inleveren bij de aankoop van het nieuwe

1.5 Of u kunt het naar de afvalverwerking brengen volgens de voorschriften van de lokale overheid.

1.6 Wij zullen de kosten van deze handelingen op ons nemen.

1.7 De apparaten zijn voorzien van een etiket met het symbool van "een doorgestreepte afvalcontainer met wielen"; dit symbool geeft aan dat het apparaat niet met het gewone afval gemengd en apart verwerkt moet worden.

1.8 Onze producten zijn ontworpen en gefabriceerd op basis van materialen en onderdelen van hoge Kwaliteit die het milieu ontzien en die hergebruikt en gerecycled kunnen worden. Desondanks zijn de diverse onderdelen van dit product niet biologisch afbreekbaar, zodat deze niet in het milieu achtergelaten mogen worden. Om dit produkt korrek te recyclen, reliev de elektrische motor van de Filterset los maken



PT - CONTENTOR DE LIXO COM RODAS BARRADO COM UMA CRUZ

1.1 Com o objectivo de reduzir a quantidade de resíduos dos equipamentos eléctricos e electrónicos, a perigosidade dos componentes, fomentar a reutilização dos equipamentos, a valorização dos seus resíduos e determinar uma gestão adequada tratando de melhorar a eficácia da protecção ambiental, estabelecese uma série de normas aplicáveis ao fabrico do produto e outras relativas à correcta gestão ambiental quando se transformam em resíduos.

1.2 Do mesmo modo, pretende-se melhorar o comportamento ambiental de todos os agentes que intervêm no ciclo de vida dos equipamentos eléctricos e electrónicos, como são os produtores, os distribuidores, os utilizadores e, em particular, o dos agentes directamente implicados na gestão dos resíduos derivados destes equipamentos.

1.3 A partir do dia 13 Agosto de 2005, quando quiser desfazer-se deste aparelho, tem duas possibilidades de devolução:

1.4 Se adquirir um novo aparelho que seja de tipo equivalente ou que realize as mesmas funções que o que está a deitar fora, poderá entregá-lo ao distribuidor, sem custo, no acto da

compra;

1.5 Poderá levá-lo ao local destinado pelas diferentes entidades locais.

1.6 Nós assumiremos os custos de gestão.

1.7 Os equipamentos são rotulados com o símbolo de um “contentor de lixo com rodas barrado com uma cruz”, que indica a necessidade de recolha selectiva e diferenciada do resto dos lixos urbanos.

1.8 Os nossos produtos são concebidos e fabricados com materiais e componentes de alta qualidade, respeitadores do ambiente, que podem ser reutilizados e reciclados. No entanto, as diferentes partes que compõem este produto não são biodegradáveis e, portanto, não devem ser abandonadas no meio ambiente. Para a reciclagem correta deste equipamento, por favor separe o motor eléctrico do resto do aparelho de filtração.

● We reserve the right to change all or part of the articles or contents of this document, without prior notice.

● Nos reservamos el derecho de cambiar total o parcialmente las características de nuestros artículos o el contenido de este documento sin previo aviso.

● Nous nous réservons le droit de modifier totalement ou en partie les caractéristiques de nos articles ou le contenu de ce document sans préavis.

● Wir behalten uns das Recht vor, die technischen Daten unserer Artikel oder den Inhalt dieses Dokumentes ohne vorherigen Hinweis ganz oder teilweise zu ändern.

● Ci riserviamo il diritto di cambiare totalmente o parzialmente le caratteristiche tecniche dei nostri prodotti ed il contenuto di questo documento senza nessun preavviso.

● Wij behouden ons het recht voor geheel of gedeeltelijk de kenmerken van onze artikelen of de inhoud van deze handleiding zonder voorafgaand bericht te wijzigen.

● Reservamo-nos o direito de alterar, total ou parcialmente, as características dos nossos artigos ou o conteúdo deste documento sem avis

ITEM REFERENCE/REFERENCIA DEL ARTÍCULO

EVIDENCE OF CONFORMITY / DECLARACIÓN DE CONFORMIDAD / DÉCLARATION DE CONFORMITÉ / KONFORMITÄTSERKLÄRUNG / DICHIARAZIONE DI CONFOMITA / OVEREENSTEMMIGGSVERK LARING / DECLARAÇÃO DE CONFORMIDADE.

-The products listed above are in compliance with the safety prescriptions:

- 2014/30/EU Electromagnetic compatibility Directive (EMC)
- 2014/35/EU Low voltage Directive (LVD)
- 2011/65/EU European Directive (RoHS)
- EU REACH regulation 1907/2006.
- 2012/19/EU WEEE
- 2006/42/EC Machine directive

-Los productos arriba enumerados se hallan conformes con:

- Directiva de compatibilidad electromagnética 2014/30/EU (EMC)
- Directiva de equipos de baja tensión 2014/35/EU (LVD)
- Directiva Europea 2011/65/EU (RoHS)
- Reglamento REACH 1907/2006.
- 2012/19/EU WEEE
- 2006/42/CE Directiva de máquinas

-Les produits énumérés ci-dessus sont conformes aux prescriptions de sécurité:

- Directive de compatibilité électromagnétique 2014/30/EU (EMC)
- Directive d'équipés de basse tension 2014/35/EU (LVD)
- Directive Européenne 2011/65/EU (RoHS)
- Le règlement REACH 1907/2006.
- 2012/19/EU WEEE
- 2006/42/EC Directive machines

- Die obenangeführten Produkte entsprechen den Sicherheitsbestimmungen:

- Richtlinie 2014/30/EU über elektromagnetische Verträglichkeit (EMC)
- Richtlinie 2014/35/EU über die Sicherheit von elektrischen Betriebsmitteln (Niederspannungsrichtlinie) (LVD)
- Europäischen Richtlinie 2011/65/EU (RoHS)
- REACH Verordnung 1907/2006.
- 2012/19/EU WEEE
- 2006/42/EC Maschinenrichtlinie

-I prodotti su elencati sono conformi al quanto segue:

- Direttiva sulla compatibilità elettromagnetica 2014/30/EU (EMC)
- Direttiva apparecchiatura in bassa tensione 2014/35/EU (LVD)
- Direttiva Europea 2011/65/EU (RoHS)
- Regolamento REACH 1907/2006.
- 2012/19/EU WEEE
- 2006/42/EC Direttiva macchine

-De bovengenoemde producten zijn conform de zekerheidsrichtlijnen:

- De richtlijn betreffende elektromagnetische compatibiliteit 2014/30/EU (EMC)
- De laagspanningsrichtlijn 2014/35/EU (LVD)
- Europese Richtlijn 2011/65/EU.
- Europese REACH Verordening 1907/2006/EG.
- 2012/19/EU WEEE
- 2006/42/EC Maskindirektivet

-Os produtos da lista acima estão conformes as:

- Directiva de compatibilidade electromagnética 2014/30/EU (EMC)
- Directiva de equipamentos de baixa tensão 2014/35/EU (LVD)
- Directiva Europeia 2011/65/EU (RoHS)
- Regulamento REACH 1907/2006
- 2012/19/EU WEEE
- 2006/42/EC Directiva de máquinas

Sign the present conformity evidence / Firma la presente declaración/ Signe la presente déclaration / Unterzeichnet diese Erklärung/ Firma la seguente dichiarazione / Ondertekent onderhavige verklaring / Assina a presente declaração:

“Guangzhou, China”, 03/12/2018

Name and position: Michael Chen, Director

Signature / Firma / Unterschrift / Assinatura

FLUIDRA

Fluidra Global Distribution

Ametllers nº 6 Polinya (Barcelona) Spain

www.astralpool.com